

Joel 2:1

Blow ye the trumpet in Zion, and sound an alarm in my holy mountain: let all the inhabitants of the land tremble: for the day of the LORD cometh, for it is nigh at hand;



God is revealing more and more new light about the application and importance of the 2520 than He did in the Millerite days. It was present truth for the early pioneers from 1798-1863, then it was set aside and forgotten. Now, within Adventism, during the time **when the repeat experience** of the Ten Virgins is in progress, the 2520 has become *PRESENT TRUTH* again.

We have nothing to fear for the future, except as we shall forget the way the Lord has led us, and His teaching in our past history.
Ellen G. White, Life Sketches, p. 196

Created by: Linda
the.2520@gmail.com

Edited by
patrick.rampy@juno.com

prophecyhelps101.com

Copyright 2014 & 2017

THE REASON FOR THIS MEASURING BOOKLET

"... Each of the ancient prophets *spoke less for their own time than for ours, so that their prophesying is in force for us.*
'Now all these things happened unto them for ensamples: and they are written for our admonition, upon whom the ends of the world are come' (1 Corinthians 10:11).
'Not unto themselves, but unto us they did minister the things, which are now reported unto you by them that have preached the gospel unto you with the Holy Ghost sent down from heaven; which things the angels desire to look into'"(1 Peter 1:12).
Selected Messages, vol. 3, p. 338

"I am instructed to say that the precious truth for this time is to open more and more clearly to human minds. In a special sense men and women are to eat of Christ's flesh and drink of His blood. There will be a development of the understanding, for **the truth is capable of constant expansion.** The divine Originator of truth will come into closer and still closer communion with those who follow on to know Him. As God's people receive His word as the bread of heaven, they will know that His goings forth are prepared as the morning. They will receive spiritual strength, as the body receives physical strength when food is eaten.

"We do not half understand the Lord's plan in taking the children of Israel from Egyptian bondage, and leading them through the wilderness into Canaan. As we gather up the divine rays shining from the gospel, we shall have a clearer insight into the Jewish economy, and a deeper appreciation of its important truths. **Our exploration of truth is yet incomplete.** We have gathered up only a few rays of light. *Those who are not daily students of the Word will not solve the problems of the Jewish economy. They will not understand the truths taught by the Temple service.* The work of God is hindered by a worldly understanding of His great plan. The future life will unfold *the meaning of the laws that Christ, enshrouded in the pillar of cloud, gave to His people*

E. G. White Letter 156, 1903, pp. 2, 3. (To P. T. Magan, July 27, 1903.)

{Manuscript Releases, vol. 3, p. 259}

FOREWORD

RIGHTEOUSNESS BY FAITH

"When the third angel's message is preached as it should be, power attends its proclamation, and it becomes an abiding influence. **It must be attended with divine power, or** it will accomplish nothing. I am often referred to the parable of the ten virgins, five of whom were wise, and five foolish. This parable has been and will be fulfilled to the very letter. for it has a special application to this time, and, like the third angel's message, has been fulfilled and will continue to be present truth till the close of time." RH, August 19, 1890

WHAT IS THE SPECIAL APPLICATION FOR US?

Answer: "Divine power" and "righteousness by faith".

"In the parable, the ten virgins had lamps, but only five of them had the saving oil [righteousness by faith] with which to keep their lamps burning. This represents the condition of the Church. The wise and the foolish have their Bibles, and are provided with all the means of grace; but many do not appreciate the fact that they must have the heavenly unction. They do not heed the invitation, 'Come unto me, all ye that labor and are heavy laden, and I will give you rest. Take my yoke upon you, and learn of me; for I am meek and lowly in heart: and ye shall *find rest unto your souls*. For my yoke is easy, and my burden is light.' " Ibid.

The "heavenly unction":

Websters 1848: UNCTION: n. The act of anointing.

WHY DID THE DOOR SHUT ON FIVE FOOLISH VIRGINS?

"The class represented by the foolish virgins are not hypocrites. They have a regard for the truth, they have advocated the truth, they are attracted to those who believe the truth; but they have not yielded themselves to the Holy Spirit's working."

Christ's Object Lessons, p. 411

"There are persons who have received the precious light of the righteousness of Christ, but they do not act upon it; they are foolish virgins. ..." RH, August 19, 1890

They [foolish virgins] had all the light, all the knowledge, but they failed to obtain the oil of grace; they did not receive the truth in its sanctifying power.
...This represents the condition of the Church."
RH, August 19, 1890

A NEW HEART

"To be pardoned in the way that Christ pardons, is not only to be forgiven, but to be renewed in the spirit of our mind. The Lord says, '**A new heart will I give unto thee.**' The image of Christ is to be stamped upon the very mind, heart, and soul. The apostle says, 'And we have the mind of Christ.' **Without the transforming process which can come alone through divine power, the original propensities to sin are left in the heart in all their strength,** to forge new chains, to impose a slavery that can never be broken by human power. But men can never enter heaven with their old tastes, inclinations, idols, ideas, and theories. Heaven would be no place of joy to them; for everything would be in collision with their tastes, appetites, and inclinations, and painfully opposed to their natural and cultivated traits of character." RH, August 19, 1890

STEPS TO CHRIST, p. 62:

"Then with Christ working in you, you will manifest the same spirit and do the same good works --works of righteousness, obedience." Christ changes the heart. He abides in your heart by faith. You are to maintain this connection with Christ by faith and the continual surrender of your will to Him;"

WHAT DOES RIGHTEOUSNESS BY FAITH HAVE TO DO WITH THE 2520?

Surrendering our will to do His will,
is the only means whereby we can obey all the commandments of God.

THE 2520 "SEVEN TIMES" WAS A WARNING TO OBEY ALL THE COMMANDMENTS OF GOD

"God is the fountain of life; and when one chooses the service of sin, he separates from God, and thus cuts himself off from life." {DA 764.1}

Satan claims that it is "impossible for man to keep God's law." PP 77
The precious message from heaven is that by the same faith of Jesus we can keep the law, and the 2520 is a warning to fill our vessels with divine oil because the door is about to shut.

Righteousness by faith was rejected in 1888 because "*The enemy has men in our ranks through whom he works*, that the light which God has permitted to shine upon the heart and illuminate the chambers of the mind may be darkened" (RH, 8/19/1890). **If Satan can keep us from holiness (righteousness by faith), he has proven God to be unfair, and he will ask entrance back into heaven.** Read *Story of Redemption*, p. 27.

"The state of the Church represented by the foolish virgins, is also spoken of as the Laodicean state." Ibid.

"The Lord in His great mercy sent a most precious message to His people through Elders Waggoner and Jones. This message was to bring more prominently before the world the uplifted Saviour, the sacrifice for the sins of the whole world. It presented justification through faith in the Surety; it invited the people to receive the righteousness of Christ, which is made manifest in obedience to all the commandments of God. {Last Day Events, p. 200}

1 John 3:9 - Whosoever is born of God doth not commit sin;
God is sending Laodicea a message of warning via the 2520 that the time
to surrender our will to His and become a Holy people is about over.

"Be ye holy, for I am holy." 1 Peter 1:16

**The door is closing on the foolish virgins who
are neglecting to fill their vessels with divine oil.**

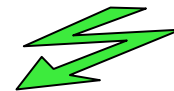

What does this mean: "fill their vessels with divine oil"?
It means that God has sent the Holy Spirit to us with the
divine power to enable us to put away all sins, there is
no excuse for not being an overcomer.

"...Divine power will combine with human effort, when
we seek earnestly to be complete in Christ Jesus. ..."
Youth's Instructor, September 20, 1894

"The time of God's destructive judgments [after national Sunday law] is the time of mercy for those who have no opportunity to learn what is truth. Tenderly will the Lord look upon them. His heart of mercy is touched; His hand is still stretched out to save, while the **door is closed to those who would not enter** [via righteousness by faith]. Large numbers will be admitted who in these last days hear the truth for the first time [and by faith will take a stand]"- (RH July 5, 1906). {7BC 979.3}

INTRODUCTION

“O, the end is near! Who is ready for Christ to rise from his throne to put on the garments of vengeance? Whose names are registered in the Lamb's book of life?”

Special Testimonies Series A, p. 7

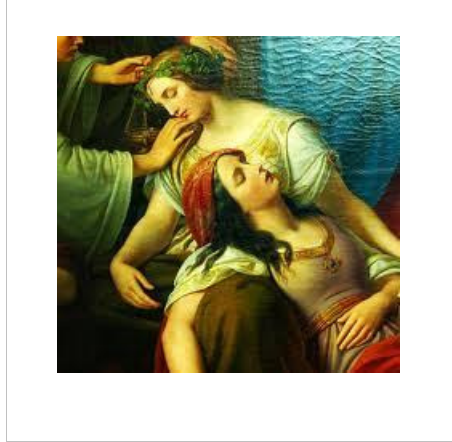

Ephesians 5:14 - Wherefore he saith, *Awake* thou that sleepest, and **arise [stand up]** from the dead, [Eze. 37] and Christ shall give thee light.

Revelation 11:1 - And there was given me a reed like unto a rod: and the angel stood, saying, *Rise*, ...

Ezekiel 37:10 - So I prophesied as he commanded me, and the breath came into them, and they lived, and *stood up upon their feet*, ...

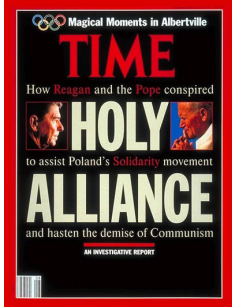
<p>1840 - 1844 TEN VIRGINS AROSE <i>RISE</i> – #1453 (Strong's)</p> <p>Matt 25:6-7 And at midnight there was a cry made, Behold, the bridegroom cometh; go ye out to meet him. Then all those virgins <i>arose</i> [rouse from sleep], and <u>trimmed their lamps</u>.</p>	<p>JUNE 1982</p>  <p>UNHOLY ALLIANCE</p>	<p>1989 - SUNDAY LAW TEN VIRGINS AROSE AGAIN <i>AROSE</i> #1453 (Strong's)</p> <p>Matt 25:6-7 And at midnight there was a cry made, Behold, the bridegroom cometh; go ye out to meet him. Then all those virgins <i>arose</i> [rise again], and <u>trimmed their lamps</u>.</p>
---	---	--

AROSE --NT:1453 egeiro (eg-i'-ro); probably akin to the base of NT:58

(through the idea of collecting one's faculties); to waken (transitively or intransitively), i.e. rouse (literally, from sleep, from sitting or lying, from disease, from death; or figuratively, from obscurity, inactivity, ruins, nonexistence): KJV - awake, lift (up), raise (again, up), rear up, (a-) rise (again, up), stand, take up

“This parable has been, and will be fulfilled to the very letter.”

R&H, August 18, 1890

NOTES

CHAPTER 1

THE 2520

THE PATTERN

When I visit your home, do I need to know the detailed measurements of your house plan?
No, not unless I want to build a house exactly like yours.
Why did God give us the measurements of His three homes?

Answer:

We need to build a character just like His.

His character is represented by the measurements in His Temples. Those measures symbolize the Law of God, the Ten Commandments.

"Ye shall be holy." This is the keynote of the book of Leviticus.
Throughout the book stress is ever on holiness. 1BC, p. 788

Holiness & obedience vs worldliness & rebellion is the bottom-line message of the 2520!

THE LITERAL TEMPLE SYMBOLIZES THE THRONE OF GOD	THE SPIRITUAL TEMPLE SYMBOLIZES THE CHARACTER OF GOD
<p>"In the <u>building of the sanctuary</u> as a dwelling place for God, (Rev. 7:15, Ex. 25:8), Moses was directed to make all things according to the pattern [literal blueprint] of things in the heavens. God called him into the mount, and revealed to him the heavenly things, and in their similitude the tabernacle, with all that pertained to it, was fashioned." E.G. White, <i>Education</i>, p. 35</p>	<p>"So to Israel, whom He desired to make His dwelling place, He revealed His glorious ideal of character. The pattern [God's character] was shown them in the mount when the law was given from Sinai and when God passed by before Moses and proclaimed, "The Lord, The Lord God, merciful and gracious, long-suffering, and abundant in goodness and truth." Exodus 34:6. Ibid</p>

"Consider the prophecy of Malachi in connection with Daniel, Zephaniah, Haggai, and Zechariah. Let the teaching of these books be carefully investigated, **also the building of the temple [measuring]**, and the temple service. Through the prophets, God has given a delineation of what will come to pass in the last days of this earth's history; and the **Jewish economy [the sabbaths-of-the-land-law]** is full of **instruction** for us."
E.G. White, *Southern Watchman*, October 9, 1906

WILLIAM MILLER

GOD SENT HIS ANGEL TO WILLIAM MILLER

"I saw that God sent *His angel* to move upon the heart of a farmer who had not believed the Bible, and led him to search the prophecies. *Angels of God repeatedly visited that chosen one*, and guided his mind, and opened his understanding to prophecies which had ever been dark to God's people. The *commencement* of the chain of truth was given him, and he was led on to search for link after link, until he looked with wonder and admiration upon the word of God. ..."

Early Writings, p. 229

“LINK after LINK”

2520 - 2300 - 1260 - 1335, etc.

WILLIAM MILLER'S DREAM

"I dreamed that God, by an unseen hand, sent me a curiously wrought casket about ten inches long by six square, made of ebony and pearls curiously inlaid. To the casket there was a key attached. I immediately took the key and opened the casket, when, to my wonder and surprise, I found it filled with all sorts and sizes of jewels, diamonds, precious stones, and gold and silver coin of every dimension and value, beautifully arranged in their several places in the casket; and thus arranged they reflected a light and glory equaled only to the sun."

E.G. White, *Early Writings*, p. 81

The dimensions of the casket were $10 \times 6 \times 6 = 360$.

360 was the "key" that opened the door for William Miller to understand first the prophecy of the "seven times" of Lev. 25& 26, and then the prophecy of the 2300 days.

"I was satisfied that the seven times terminated in 1843.

Then *I came to the 2300 days*; they brought me to the *same conclusion*."

Wm. Miller as quoted by Apollon Hale in *The Second Advent Manual*, p. 65

(emphasis supplied)

Miller's method of Bible study, comparing scripture with scripture – using the Bible as its own interpreter, is known as the "proof-text" method.

The majority of Bible scholars today use the "historical-critical method" which puts human reason above the word of God.

WHAT IS THE 2520?

$$7 \times 360 = 2520$$

1. 2520 is a sum found over and over in the measurements of the three temples and Noah's Ark. Its full significance is not yet fully understood, but one thing is for sure: **it is His number.**
2. The 2520 was the FIRST important message William Miller discovered because had "God sent His angel" (SR 356) to direct his search for truth.
3. **The 2520 is the literal number of prophetic days (360 days = one year) within a 49-year cycle which God in His "Sabbath rest-unto-the-land" law commanded the land not to be worked.** (Lev. 25:1-7 & Ex. 23:10-12).
4. The 2520 is the two seven-year periods Jacob served for his wives.
5. 1 Kings 6:38 ... So was he [Solomon] seven years [2520 days] in building it [the temple].
6. The 2520 is the 1260 years paganism trampled the host (723 B.C. to 538 A.D.) added to the 1260 years papalism trampled the host (538 to 1798).
7. The 2520 is the literal number of years from the kingdom of Judah lost its national sovereignty, 677 B.C. until Christ entered into the Most Holy in 1844 A.D.
8. Nebuchadnezzar's experience with the beasts of the field is a prophetic 2520 days (7 x 360) and the image he set up is 1260 in. by 126 in. according to the 21 in. "cubit and an handbreadth" (Eze. 40:5).
9. The 2520 is 2520 gerahs or 126 shekels, symbolic of the words "mene mene, tekel, upharsin" written upon the wall by a bloodless hand. Nebuchadnezzar's 2520 was a warning to Belshazzar, that he ignored. Therefore the 2520 pronounced judgment upon Belshazzar (Daniel 5:26).
10. **For seven years [2520 days of the 70th week] after the Savior entered on His ministry, the gospel was to be preached especially to the Jews; E.G. White, *Desire of Ages*, p. 233**
11. For seven years [2520 days] a man continued to go up and down the streets of Jerusalem declaring the woes that were to come upon the city. *Great Controversy*, p. 30.
12. There were 2520 "daily sacrifice" Lambs³ during the 3.5 years Christ walked the earth, and the meal offerings with those Lambs measured 4 x 126⁴ deals of Flour and 1260 (1/2 of 2520) hins of Oil & Wine.
13. James White wrote in 1856: "The appointed seven prophetic times of Moses' prophecy, was a portion of the **hidden wisdom of God**, hidden for ages." Ironically, it was White who later hid it again in the year 1863! Early the next year he published his new opinion in a short article. ARSH, vol. 23, (Jan. 26, 1864).

The SDA Pioneers were somewhat divided on its application and importance.

Hiram Edson favored the first 2520 (723 B.C.-1798 A.D.)

William Miller favored the last 2520 (677 B.C.-1844 A.D.).

Today, we know that both of them are present truth messages!

God's people were scattered during the two 2520 periods, and then began to be gathered in the 46 years between 1798 and 1844. Of those gathered at that time, only about 50 proved faithful and walked into the Most Holy with Jesus after Oct. 22, 1844. Those 50 went on to become "Spiritual Israel", God's denominated people, bearing His Name: Seventh-day Adventist.

THE 2520 IS THE GREAT CONTROVERSY BETWEEN GOOD AND EVIL

It is a blessing for holiness (Lev. 25 and 26:4-13; Deut. 28:1-14).

It is a curse for worldliness (Lev. 26: 14-39; Deut. 28:14-68).

<p>Deut. 11:26 Behold, I set before you this day a blessing and a curse;</p>	<p>Jer. 21:8 Thus saith the LORD; Behold, I set before you the way of life, and the way of death.</p>
--	---

GOD'S LAW = HOLINESS = BLESSINGS = LIFE



Rev. 22:14

Blessed are they that do his commandments,
that they may have right to the tree of life, and may
enter in through the gates into the city.

Rev. 20:6

Blessed and holy is he that hath part in the first resurrection: on
such the second death hath no power, but they shall be priests of
God and of Christ, and shall reign with him a thousand years

LUCIFER'S LAW = WORLDLINESS = CURSES = DEATH

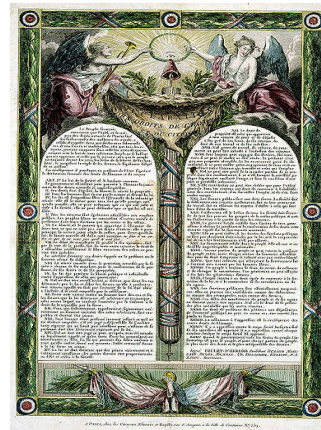

The
"rights of man"
as put forth
by Voltaire.

Rev. 16:1

And I heard a great voice out of the temple saying to the
seven angels, Go your ways, and pour out the vials of the
wrath of God upon the earth.

Rev. 20:15

And whosoever was not found written in the
book of life was cast into the lake of fire.

**Worldliness results in people ignoring and breaking the Sabbath today
just as it led them to break the Sabbath law (Ex. 20) and the Sabbaths-of-the-land law
(Ex. 23 & Lev. 25) of ancient Israel.**

"Modern Israel are in greater danger of forgetting God and
being led into idolatry than were His ancient people." 1T 609

Ellen G. White refers to the 2520 in The Great Controversy.

<p>Great Controversy, p. 32.</p> <p>“Again was fulfilled the warning prophecy given fourteen centuries before: ...”</p> <p>E.G. White in describing the siege of Jerusalem by the Roman general Titus quotes from Deut. 28:56-57 and writes that this is a "prophecy" from the time of Moses. This chapter is the blessings for obedience, and the curses for disobedience. Deut. 28 is a recap of Lev. 26. where the "seven times" curse for disobedience is specifically brought to the people's attention.</p>	
<p>Leviticus 26</p> <p>PROPHECY AT THE BEGINNING OF THE EXODUS</p> <p>v. 4 -13 Emphasizes the blessings of the covenant.</p> <p>v. 14 - But if ye will not hearken unto me, ...</p> <p>14 - 43 Moses tells of the curses for disobedience.</p>	<p>Deuteronomy 28</p> <p>RECAP-PROPHECY GIVEN AT THE END OF THE 40 YEARS</p> <p>v. 3-14 Emphasizes the blessings of the covenant.</p> <p>v. 15 ... if thou wilt not hearken ...</p> <p>16-68 - Moses tells of the curses for disobedience.</p>
<p>Great Controversy, p. 351</p> <p>"The experience of the disciples who preached the "gospel of the kingdom" at the first advent of Christ, had its counterpart in the experience of those who proclaimed the message of His second advent. As the disciples went out preaching, "The time is fulfilled, the kingdom of God is at hand," so Miller and his associates proclaimed that the longest and last prophetic period brought to view in the Bible was about to expire, that the judgment was at hand, and the everlasting kingdom was to be ushered in. The preaching of the disciples in regard to time was based on the seventy weeks of Daniel 9. The message given by Miller and his associates announced the termination of the 2300 days of Daniel 8:14, of which the seventy weeks form a part. The preaching of each [the 490 & 2300] was based upon the fulfillment of a different portion of the same great prophetic period" [ie. the 2520]</p> <p>To have a "last" there must also be a "first". The first "great prophetic period" was the first 2520 that marked the fall of the northern kingdom in 723 B.C. and ended in 1798, and the "last" great prophetic period was the second 2520 from 677 B.C. to 1844.</p> <p>"It is God's plan to give sufficient evidence of the divine character of His work to convince all who honestly desire to know the truth. But He never removes all opportunity for doubt. All who desire to question and cavil will find occasion." <i>Selected Messages</i>, Vol. 1, p. 72</p>	

The 1863 chart by James White:

Critics of the 2520-year prophecy point out that it is not on the 1863 chart.

But note that the 1260, 1290 & 1335-year prophecies also do not appear on that chart, but they are still taught as valid prophecies. However, there is a good reason for the removal of the 2520 - the church had become Laodicea seven years previous. God did not inspire a new chart, and neither did Ellen White give an endorsement of the 1863 chart, in fact, she mentions it only twice (1T 689 and RH March 29, 1870).

Back in 1853 she wrote: "I saw that the charts **ordered by God** struck the mind favorably, even without an explanation." Manuscript 1, 1853, p. 6-7.

(However, the 7 years of Christ's final week on the 1863 chart was 2520 days long.)

THE LEVITES WERE TO
REPRESENT THE CHARACTER OF GOD
AND INSTRUCT IN THE WAYS OF RIGHTEOUSNESS

"When Israel entered Canaan (c. 1406/1405 B.C.) the Lord had commanded them to assign cities to the Levites throughout the various tribes. Thus *instruction in ways of righteousness* might be given to all the people, **but they seem to have paid little or no attention to the command.** *Seventh-day Adventist Bible Commentary*, vol.2, p.449

They did not in fact, even drive out the Canaanites, but *dwelt among them.* (Judges 1:21,27,29-33). *ibid*

"...Israel violated God's plan that the Levites should *instruct the people in His ways*, and soon lapsed into the ignorant, *superstitious ways of the heathen* about them." *ibid*

"*Six times* during the period of the judges God sought to awaken His people to their error of their course by permitting them to *become subject to the surrounding nations.* But soon after each deliverance from servitude, they lapsed into indifference and idolatry." *ibid*

The **seventh time** was the beginning of the first "SEVEN TIMES"
curse or 2520 on the northern kingdom of Israel *when king Hoshea was taken prisoner.*

(See Lev. 26: 18, 21, 24, 28).

The **eighth time** was the beginning of the second "SEVEN TIMES"
curse or 2520 on the southern kingdom of Judah.

"This prophecy (Deut. 4) fulfilled in part in the time of the judges, (the previous six times) met a more complete and literal fulfillment in the captivity of Israel (the seventh time) in Assyria and of Judah (the eighth time) in Babylon." *Prophets and Kings*, p. 296

(For more information, see comments in the SDABC, vol. 2, p. 304.)

The 70 years literal captivity of the southern kingdom in Babylon was a temporary judgment and part of the 2520, but not the complete fulfillment. The captivity of the northern kingdom was the "complete and literal fulfillment" of those tribes as far as their connection with Bible prophecy. These tribes disappeared from the pages of history: "After the destruction of Samaria in 723/722 B.C., when the ten northern tribes ceased to exist as a separate nation, the kingdom of Judah remained the sole representative of the descendants of Jacob or Israel." 4BC p.757.

The Seventh-day Adventist Bible Commentary, Vol. 1, p. 969, informs us that Deut. 4:27 refers to Leviticus 26:32-33. In doing so, the commentary states that *this scattering* refers to their captivity by the Assyrians, Babylonians and the siege of **Samaria and Jerusalem** (see commentary comments on verse 27). Pagan Rome entered the "glorious land" in 63 B.C. (Dan. 11:16), 544 years *after* their Babylonian captivity and 475 years after the first decree of Darius.

Assyria removed the crown of national sovereignty
from the divided kingdoms of Israel and Judah.

Isaiah 10:5

"O Assyrian, the rod of mine anger,
and the staff in their hand is mine indignation."

2 Kings 17:6

In the ninth year of Hoshea the king of Assyria took Samaria,
and carried Israel away into Assyria, and placed them in Halah
and in Habor by the river of Gozan, and in the cities of the Medes.

2 Chronicles 33:11

Wherefore the LORD brought upon them the captains of the host of
the king of Assyria, which took Manasseh among the thorns,
and bound him with fetters, and carried him to Babylon.

Nebuchadnezzar's Babylon replaced Assyria as the most powerful
nation on earth at the Battle of Carchemish 605BC.

"The ***crown removed from Israel*** passed successively to the kingdoms of
Babylon, Medo-Persia, Greece, and Rome. God says, "***It shall be no more,***
until He [Jesus in 1844] come whose right it is; and I will give it Him."

Education, p. 179

723 B.C.

THE 2520 WAS ISRAEL'S LOSS OF NATIONAL SOVEREIGNTY

THE
DAILY
ABOMINATION

THE TRANSGRESSION
OR ABOMINATION
OF DESOLATION

**723 B.C. - 1798 A.D. was the 2520 years of the “SEVEN TIMES” curse* of the two abominations:
3.5 times (1260 years) of PAGANISM, and 3.5 times (1260 years) of the PAPACY.**

Leviticus 26:1-2
Ye shall make you
no idols nor graven image,
neither rear you up a standing image,
neither shall ye set up any image
of stone in your land,
to bow down unto it: for

**I AM
THE LORD YOUR GOD.**

Ye shall keep *my sabbaths,*
and
reverence my sanctuary:

**I AM
THE LORD.**

Verses 4-12:

The blessings for obedience included this promise: And ye shall chase your enemies, and they shall fall before you by the sword. And five of you shall chase an hundred, and an hundred of you shall put ten thousand to flight: and your enemies shall fall before you by the sword.

2 Kings 17:6-17 In the ninth year of Hoshea the king of Assyria took Samaria, and carried Israel away into Assyria, ... For so it was, that the children of Israel had sinned against the LORD their God, ...and had *feared other gods,* And walked in the statutes of the heathen, ...And the children of Israel did secretly those things that were not right against the LORD their God, ...And *they set them up images* and groves in every high hill, and under every green tree: And there they burnt incense in all the high places, ...*For they served idols,* whereof the LORD had said unto them, *Ye shall not do this thing.* Yet the LORD testified against Israel, and against Judah, by all the prophets, and by all the seers, saying, Turn ye from your evil ways, and keep my commandments and my statutes, according to all the law which I commanded your fathers, and which I sent to you by my servants the prophets.

Notwithstanding they would not hear, but hardened their necks, ...and *served Baal.* And they caused their sons and their daughters to pass through the fire, and used divination and enchantments, and sold themselves *to do evil in the sight of the LORD,* to provoke him to anger.

What idols do we worship?

2 Kings 17:18

Therefore the LORD was very angry with Israel [Samaria],
and removed them out of his sight: there was none left but the tribe of Judah only.

* Lev. 26:18, 21, 24, 28

677 B.C.

THE 2520 WAS JUDAH'S LOSS OF NATIONAL SOVEREIGNTY

beginning in the year 677 B.C. and continuing for "SEVEN TIMES"* or 2520 years, ending when Christ entered the Most Holy and began His work of judgment on Oct. 22, 1844.

For 46 years (723-677bc) Judah had time to observe the consequences of the removal of the king and loss of national sovereignty of the northern kingdom of Israel.

"Inasmuch as Judah had before her the example of her sister Israel and had failed to profit by the example, she will be held even more accountable."

Seventh-day Adventist Bible Commentary, Vol. 2, p. 97

Leviticus 26:1-2

Ye shall *make you no idols nor graven image*, neither rear you up a standing image, neither shall ye set up any image of stone in your land, to bow down unto it: for

I AM THE LORD YOUR GOD.

Ye shall keep *my sabbaths*, and *reverence my sanctuary*: **I AM THE LORD.**

2 Kings 21:1-5

Manasseh was twelve years old when he began to reign, and reigned fifty and five years in Jerusalem. .. **he reared up altars for Baal**, and made a grove, as did Ahab king of Israel; and worshiped all the host of heaven, and served them. And he **built altars** in the *house of the LORD, of which the LORD said, In Jerusalem will I put my name.* And **he built altars** for all the host of heaven in the two *courts of the house of the LORD.*

The stiff-necked people would not hearken – Jeremiah 17:23

2 Kings 21:9-12 But they hearkened not: and Manasseh seduced them to do *more evil than did the nations whom the LORD destroyed before the children of Israel.* And the LORD spake by his servants the prophets, saying, Because Manasseh king of Judah hath done these abominations, and hath done wickedly above all that the Amorites did, which were before him, and hath made Judah also to sin with his idols: Therefore thus saith the LORD God of Israel,

Behold, I am bringing such evil upon Jerusalem and Judah, that whosoever heareth of it, both his ears shall tingle!

Verse 13 - And I will stretch over Jerusalem the line of Samaria, and the plummet of the house of Ahab: and I will wipe Jerusalem as a man wipeth a dish, wiping it, and turning it upside down.

Manasseh was taken prisoner by the Assyrians in 677 B.C.
He repented and was returned back to Judah,
but from that time forward Judah, its kings and people lost their national sovereignty and were the subjects of foreign kings.

* Lev. 26: 18, 21, 24, 28

2520 Chart

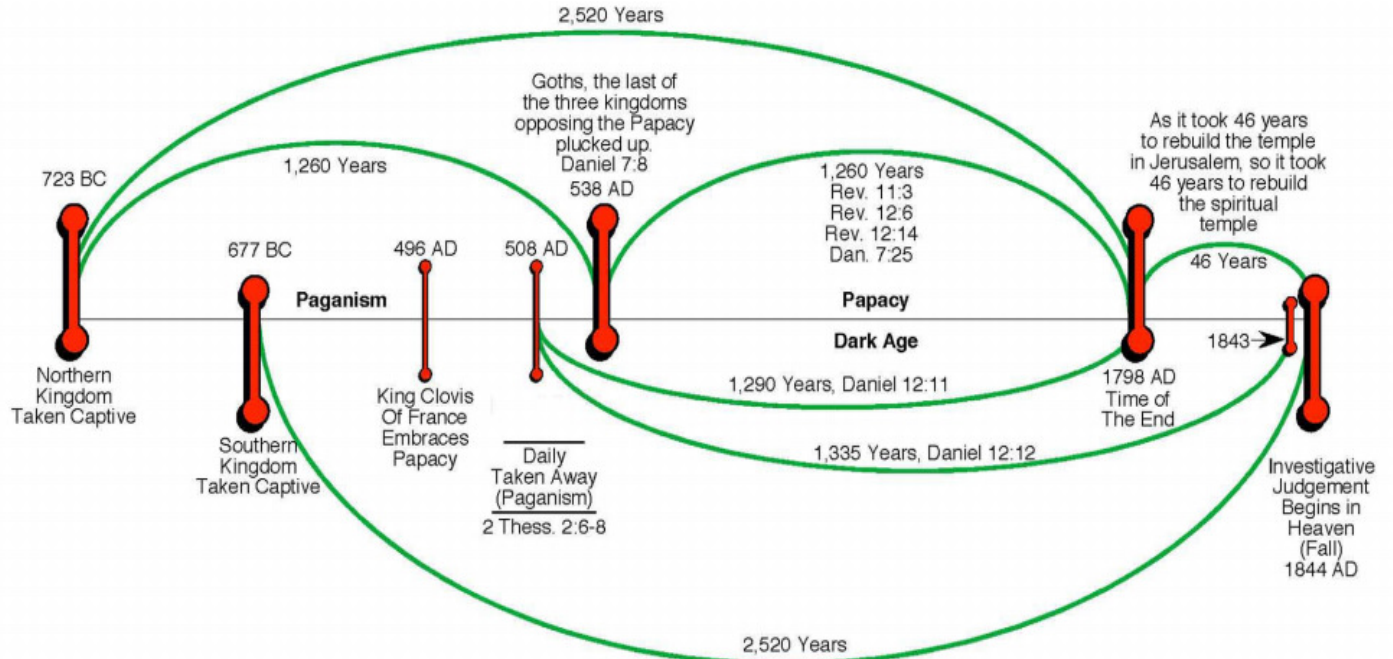

THE “SEVEN TIMES” IS ALSO KNOWN BY OTHER TERMS:

<p style="text-align: center;">THE CURSE OF MOSES</p> <p>Nehemiah 10:29 “They clave to their brethren, their nobles, and entered into a curse, and into an [seven times] oath, to walk in God’s law, which was given by Moses the servant of God, and to observe and do all the commandments of the LORD our Lord, and his judgments and his statutes; ...”</p>	<p style="text-align: center;">THE SCATTERING</p> <p>Deut. 30:3 “That then the LORD thy God will turn thy captivity, and have compassion upon thee, and will return and gather thee from all the nations, whither the LORD thy God hath scattered thee.”</p>
<p style="text-align: center;">THE INDIGNATION</p> <p>Deut. 29:27-28 “And the anger of the LORD was kindled against this land, to bring upon it all the curses that are written in this book: And the LORD rooted them out of their land in anger, and in wrath, and in great indignation, and cast them into another land, as it is this day.”</p>	<p style="text-align: center;">THE TIMES OF THE GENTILES</p> <p>Luke 21:24 “And they shall fall by the edge of the sword, and shall be led away captive into all nations: and Jerusalem shall be trodden down of the Gentiles, until the times of the Gentiles be fulfilled.”</p>

NEBUCHADNEZZAR

677 - 607 B.C. is 70 YEARS

SDA Bible Commentary, Vol. 3, p. 306: "The history of Judah has now become a mere succession of reforms and relapses, which each king following in the steps of one of his predecessors."

607 B.C.

Nebuchadnezzar set up as co-regent with his father.

"THOU ART THIS HEAD OF GOLD"

(Dan. 2:38)



70 years after Judah's loss of national sovereignty, God raises up "His servant" (Jer. 27:6) Nebuchadnezzar.

"In the year 607 B.C., Nabopolassar associated Nebuchadnezzar with himself as king, ..."
A.T. Jones, March 15, 1898 ARSH, 172

SDA Bible Commentary, Vol. 8, p. 783
"607 B.C. an astronomical text establishes *beyond doubt* the B.C. dating of his REGNAL years."

IMPORTANT!

**God established a principle for determining the beginning and ending years for prophecies:
Kings/Rulers are either set-up, put-down, or a king makes a decree.**

Examples:

723 B.C. King Hoshea taken prisoner (beg. 2520).
677 B.C. Manasseh taken prisoner (beg. 2520).
607 B.C. Nebuchadnezzar made co-regent (beg. 70 & 2450)
537 B.C. King Cyrus makes first decree (end 70 yrs).
457 B.C. Artaxerxes makes third decree (beg. 2300).

508 A.D. Clovis honored with Roman titles after subduing pagan resistance to Catholicism (beg. 1290 & 1335).
538 A.D. Ostrogoth king flees Rome (beg. 1260).
1798 A.D. Pope taken prisoner (end 1260, 1290 & 2520).
1844 A.D. King Jesus enters Most Holy to receive his kingdom (end of 2300, 2450 & 2520).

607 - 537 B.C.

THE 70 YEARS PROPHECY FOR VIOLATION OF THE "SABBATHS-OF-THE-LAND" LAW OF LEV. 25.

70 x 360 days per year = 25,200 or **10 x 2520**

Jeremiah 25:12

And it shall come to pass, when seventy years are accomplished, that I will punish the king of Babylon, and that nation, saith the LORD, for their iniquity, and the land of the Chaldeans, and will make it perpetual desolations.

2 Chronicles 36:21

To fulfil the word of the LORD by the mouth of Jeremiah, until the land had enjoyed her sabbaths: for as long as she lay desolate she kept sabbath, to fulfil threescore and ten years.

This 70 years is not the 2520 curse itself, but a curse within a curse. Judah was told to willingly submit to Nebuchadnezzar. Their Temple and city would not be destroyed if they did (Jer. 27:17). In Daniel's 9:11 prayer he referred to the "curse of Moses" and the "oath" God's people had vowed, then broke, which brought upon then the removal of God's blessings of national sovereignty during the time Manasseh was king, when the crown passed from Judah to Assyria. See Leviticus 25 & 26 and the chart on the next page for the connection between the "sabbaths-of-the-land" law, the 2520, and the 70 years captivity when the land literally rested and lay desolate.

Leviticus 25:8-16 –

And thou shalt number seven sabbath of years unto thee, seven times seven years; [7 x 360 = **2520** days] and the space of the seven sabbaths of years shall be unto thee forty and nine years [49 x 360 = **17,640** days]. And ye shall hallow the fiftieth year, and proclaim liberty throughout all the land unto all the inhabitants thereof:

FIRST KING TO LAST KING

King Saul to King Zedekiah is **490 yrs.**

490 years divided by a 49 year cycle = **10 cycles**

The land should have rested for **7 years in each 49 year cycle (Lev. 25:8);**

7 years (2520 days) x 10 cycles = 70 years.

Each one of those 49 year cycles was to have **7 years (or 2520 days) "sabbaths-of-the-land" rest.**
(See chart on following page.)

Note:

The 2300 years is 46 Jubilee cycles

The 2450 is 49 Jubilee cycles or 5 x 490 years.

Three times Nebuchadnezzar came against Jerusalem. Each time he took more captives, and the third time he burnt the temple and took king Zedekiah prisoner.



Jeremiah 27:12

I spake also to Zedekiah king of Judah according to all these words, saying, Bring your necks under the yoke of the king of Babylon, and serve him and his people, and live.

70 YEARS CHRONOLOGY 607 – 537 B.C.

(Others teach 608 – 538 B.C. or 605-536 B.C.)

609 B.C. King Josiah is killed in battle.

608 B.C. Judah's people choose Jehoahaz by popular demand.

609? B.C. Autumn? 90 days later, **Egypt's** Pharaoh Necho removes Jehoahaz and sets Jehoiakim on throne. First time a king of Judah is chosen by a foreign king.

607 B.C. **NEBUCHADNEZZAR STANDS UP**
2450 Great Jubilee begins.

605 B.C. Battle of Carchemish establishes

Nebuchadnezzar as King of the North.

He soundly destroys combined armies of Syria and Egypt. Then goes to Judah.

Nebuchadnezzar takes first set of prisoners back to Babylon including Daniel

586 B.C. Destruction of Jerusalem

538 B.C. Fall of Babylon

537 B.C. *Autumn:* Cyrus issues first decree.

A small number of Jews return in spring of 536.

(Note that our Jehovah's Witness friends also count the 2520, but from 607BC to 1914 when they got persecuted for their non-combat stance.)

OUT OF EVERY 49 YEARS, 7 YEARS OR 2520 DAYS BELONGED TO GOD

After 2520 days were accumulated, there was to be a Jubilee and a Feast of Tabernacles when the law was to be read (Deut. 31:11).

Leviticus 25:8-16 – And thou shalt number seven sabbaths of years unto thee, seven times seven years; [7x2520 = 17,640] and the space of the seven sabbaths of years shall be unto thee forty and nine years [49x360 = 17,640]. And ye shall hallow the fiftieth year, and proclaim liberty throughout all the land unto all the inhabitants thereof:

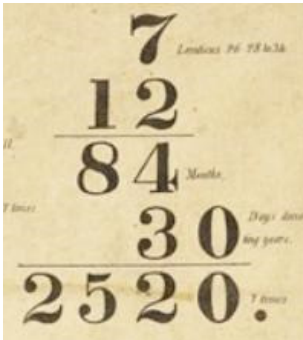
<p>William Miller's calculation was displayed on the 1843 chart like this:</p> <p>7 years x 12 months = 84 months 84 months x 30 days = 2520 days</p> 	<p>The Israelites were to till, sow and reap the land for six years, then they were to let the land have a “sabbath rest” the seventh year.</p>	
	Till, sow & reap for six years.	Land rests for one year = 360 days
	Till, sow & reap for six years.	Land rests for one year = 360 days
	Till, sow & reap for six years.	Land rests for one year = 360 days
	Till, sow & reap for six years.	Land rests for one year = 360 days
	Till, sow & reap for six years.	Land rests for one year = 360 days
	Till, sow & reap for six years.	Land rests for one year = 360 days
	42 years tilling, sowing & reaping.	7 years of “rest” every 49 years.
	42 x 360 = 15,120 or 6 x 2520	7 yrs. x 360 days per yr. = 1 x 2520
	<p style="text-align: center;">These <u>6</u> x 2520 literal days (42 years) of each 49-year Jubilee cycle belonged to <u>man</u>.</p>	<p style="text-align: center;">These <u>1</u> x 2520 literal days (seven years) of each 49-year Jubilee cycle belonged to <u>God</u>.</p>

<p style="text-align: center;">"Special laws were given to the Israelites in regard to the tilling of the soil. [Leviticus 25:1-7, quoted.] These laws seem peculiar to those who have not known God's statutes; but the Lord knew better than man what arrangements to make with His people. These laws were written down, and the <u>seventh year after they settled in Canaan was to be a Sabbath year.</u>--"</p> <p style="text-align: center;">Ms 121, 1899, pp. 4, 5. {6MR 394.1}</p>
<p style="text-align: center;">The creation Sabbath and the Sabbath-of-the-land laws in Exodus 23:10-12:</p> <p>And <u>six years</u> thou shalt sow thy land, and shalt gather in the fruits thereof: But <u>the seventh year</u> thou shalt let it rest and lie still; ... Six days thou shalt do thy work, and on the seventh day thou shalt rest:</p>
<p style="text-align: center;">The law in Leviticus:</p> <p>Lev. 25:1-5 And the LORD spake unto Moses in mount Sinai, saying, Speak unto the children of Israel, and say unto them, When ye come into the land which I give you, then shall the land keep a sabbath unto the LORD. <u>Six years</u> thou shalt sow thy field, and six years thou shalt prune thy vineyard, and gather in the fruit thereof; But in the <u>seventh year</u> shall be a sabbath of rest unto the land <u>a sabbath for the LORD</u>: thou shalt neither sow thy field, nor prune thy vineyard. That which groweth of its own accord of thy harvest thou shalt not reap, neither gather the grapes of thy vine undressed: for it is a <u>year of rest unto the land</u>.</p>

The 50th year Jubilee was a year of release and was a type of Pentecost.
 “For ten days the disciples offered their petitions for the outpouring of the Spirit, and Christ in heaven added His intercession. This was the occasion of His ascension and inauguration, a jubilee in heaven.”
 Signs of the Times, December 1, 1898

607 B.C. → OCT. 22, 1844 = 2450 years

From 607 B.C. to when the trumpet of The Great Jubilee sounded on Oct. 22, 1844 is 2450 years, or forty-nine 50-year Jubilee cycles.

Oct. 22, 1844
The Trumpet of the anti-typical Day of Atonement sounded and the Great Jubilee *should* have begun, *but sadly it's commencement has been delayed by Laodicea.*

“And when the never-ending blessing was pronounced on those who had honored God in keeping His Sabbath holy, there was a mighty shout of victory over the beast and over his image. *Then commenced the jubilee*, when the land should rest.”
Early Writings, p. 285



The Angel of Rev. 10 said:
“TIME SHALL BE NO LONGER.”

There are no more Jubilee cycles after Oct. 22, 1844. All prophecies based on the prophetic year of 360 days (360 = TIME) ended.

The Day of Atonement *has begun*, but we are still waiting for the commencement of the Great Jubilee.

Lev. 25:8-16 And thou shalt number seven sabbaths of years unto thee, seven times seven years; and the space of the seven sabbaths of years shall be unto thee forty and nine years. Then shalt thou cause the trumpet of the jubilee to sound on the tenth day of the seventh month, in the day of atonement shall ye make the trumpet sound throughout all your land. And ye shall hallow the fiftieth year, and proclaim liberty throughout all the land unto all the inhabitants thereof: it shall be a jubilee unto you; and ye shall return every man unto his possession, and ye shall return every man unto his family.

At this year of jubilee all Israelites who had sold themselves into slavery were set free, and all land that had been sold reverted to its original owner. This meant that no Israelite could ever be in permanent slavery; nor could any Israelite permanently lose his inheritance.

The 2300-year prophecy is 46 x the 50-year Jubilee cycle.

Adding three more Jubilee cycles to the 46 cycles of the 2300 = 49 Jubilee cycles or 2450 years.

2450 years is symbolic of the 49 years of the "sabbaths-of-the-land" law.

1844 began the 50th Jubilee -- the Great Jubilee of Jubilees.

The 2450 is also hidden in the measurements of Noah's Ark, the Temples and Altars (which we shall examine).

THE NUMBER SEVEN AND THE 2520

Seven represents the creation week and the Sabbath.
 One-half of seven does not represent the seal of God (the Sabbath).
 3.5 (or 1260) is only one half of the truth.
 7.0 (or **2520**) is the whole testimony.

**For seven years [2520 days of the 70th week]
 after the Saviour entered on His ministry, the gospel
 was to be preached especially to the Jews;
 E.G. White, *Desire of Ages*, p. 233**

Jesus was crucified in the “midst of the week” at 3.5 years or after 1260 prophetic days.
 This was only half way through the literal **2520** seven-years of Daniel 9:27 “And he shall confirm the covenant with many for one week: and in the midst of the week he shall cause the sacrifice and the oblation to cease, ...”

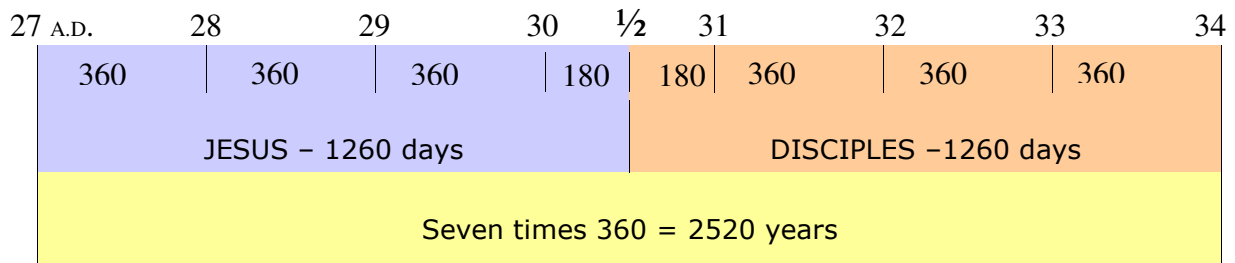

Papalism was allowed 3.5 symbolic years or 1260 literal years,
 just as Paganism was allowed 3.5 symbolic years or 1260 literal years.

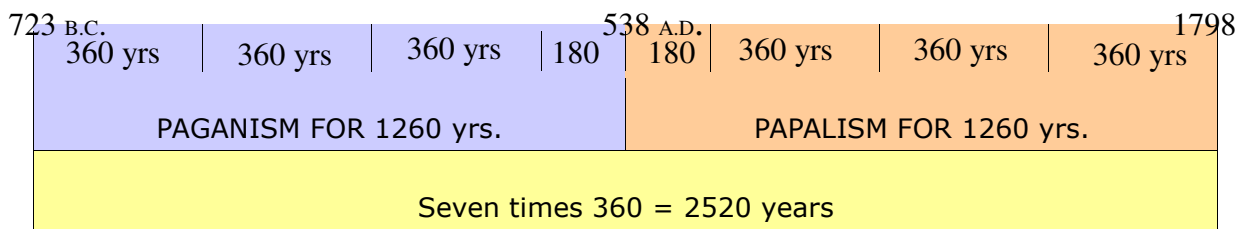

**God divides many things in half,
 but He does not do anything half-way.**



**"The truths contained in the Scriptures
...could not have originated in any human mind. ..."**

Ellen White, *Australasian Union Conference Recorder*, July 12, 1899

NOTES

CHAPTER 2

Noah's Ark & Five Different Cubits

Whatever actual *literal* USA "inch" Noah, Moses or Solomon used in the *literal* building of the Temples or Ark, *is not the object of this booklet*. God did not come out and say: "Moses, I want you to use the 18" cubit for this Tabernacle." It just so happens that most Biblical scholars generally agree on the 18" cubit for the Wilderness Tabernacle, whereas the editors of the SDA Bible Commentary prefer the 17.5" cubit (1BC 636).

God deliberately put his special numbers in different sized cubits! He knew men would not agree about which sized cubit was used. If you go on the Internet to search for cubits, there are many different sizes and the list is very long. What God did here was give us the Biblical and prophetic numbers of 2520, 2450, 1260, 144 etc., in several of the most common cubits. That is something no man could ever have planned. The cubits in this booklet happen to be the most generally accepted by Bible scholars. The perimeter of Noah's Ark measured by the five most common cubits gives us His most important Biblical numbers, the 2520 and the 2450. God knew that someday His 2520 would be denied and ridiculed by the most educated men of His Church, so He put these numbers in the perimeter of Noah's Ark to make fools of the wise, and for the simple to understand.

Some people mistakenly use the Jubilee cycle trying to figure out when Jesus will come. That is wrong. There are NO MORE TIME PROPHECIES AFTER 1844.

However, Sister White did say that if we were to follow the agricultural plan of Israel and let the land rest every seventh year it would be a blessing to all.

(Letter 221, 1899).

THE CUBIT

The exact length of a cubit has been the subject of much uncertainty and dispute.

<p style="text-align: center;">JEWISH ENCYCLOPEDIA.COM “WEIGHTS AND MEASURES”</p> <p>“Since, however, the entire system of measures corresponds almost exactly with the Babylonian, from which the Hebrew measures were in all probability derived [FROM ABRAHAM], it may be assumed that the Hebrew system corresponded with the Babylonian with regard to the absolute standard as well. It is true that the Egyptian system may have exerted some influence here and there, as will be shown later, but it is now generally recognized that the culture of ancient Syria, even before the Israelites had migrated there, was almost wholly under Babylonian influence.”</p>	<p style="text-align: center;">ENCYCLOPAEDIA BRITANNICA (1894), Vol. 24, p. 511</p> <p>“The Gemara names three Jewish cubits of 5, 6, and 7 palms; and, as Oppert shows that 25.2 was reckoned as 7 palms, 21.6 being 6 palms, we may reasonably apply this scale to the Gemara list and read it as 18, 21.6 and 25.2* inches. ...”</p> <p style="font-size: small;">*Sir Isaac Newton lists at least 6 evidences from ancient literature that the sacred cubit was close to 25 inches long. "Mr. H.W. Chisholm, Warden of the Standards of Great Britain in 1877 gives the length of the Judean Cubit of the Sanctuary as 25.50 inches and the cubit of Chaldea, Persia, etc. as 25.20 inches." http://truthmatters.info/2011/01/25/sir-isaac-newton-the-25-inch-sacred-cubit-and-noahs-ark/</p>
<p>During the French Revolution, atheistic France was the first nation to officially adopt the <u>meter</u>.</p>	<p style="text-align: center;">AMERICAN TRACT BIBLE SOCIETY: http://topicalbible.org/c/cubit.htm “...The Hebrew cubit, according to some, <u>is twenty-one inches</u>; but others fix it at <u>eighteen</u>. The Talmudists observe that the Hebrew cubit was larger by one-quarter than the Roman.”</p>
<p>Sister White writes in <i>Patriarch and Prophets</i>, p. 347</p> <p>"The tabernacle was so constructed that it could be taken apart and borne with the Israelites in all their journeyings. It was therefore small, being not more than <u>fifty-five feet in length</u>, and <u>eighteen in breadth and height</u>."</p> <p>For an unknown reason she used the cubit of 21.6".</p> <p>This cubit gives many “144” and “2520” sums.</p>	

IN THIS STUDY:

Cubit sums are converted to USA inches/feet from the duodecimal system of calculating based on the number 12.

The USA is where the Millerite Movement began,
and where the SDA church headquarters are located.
The USA is also the image-beast of prophecy.

A CUBIT CAN EQUAL YEAR(S) OR TIME

"An unusual use of the "cubit" is found in Mt 6:27
and Lk 12:25, *where it apparently refers to time*,
a usage unattested in non-Biblical Greek."
Seventh-day Adventist Bible Commentary, vol. 8, p. 252.

<p>Luke 12:25 And which of you with taking thought can add to his <i>stature</i> [years] one cubit?</p>	<p>Matthew 6:27 Which of you by taking thought can add one cubit unto his <i>stature</i> [years]?</p>
--	---

STRONG'S: "**stature**"
NT:2244 helikia (hay-lik-ee'-ah); from the same as NT:2245;
maturity (*in years* or size): *KJV* - *age*, *stature*.

For those who prefer the NIV Bible:
Matt. 6:27 -Who of you by worrying can add a single hour to his life?

There is much variation amongst scholars about the size of
Biblical cubits. The SDA Bible Commentary series ignores the
18", 21" and the 25.2" cubit. It does use the 17.5", among others.

**Note: If we multiply 17.5" x 144
the answer is 2520.**

NOAH'S ARK AS MEASURED BY FIVE DIFFERENT CUBITS

This is a truth from scripture that could not have originated in any human mind.

Genesis 7:1-- And the LORD said unto Noah,
Come thou and all thy house into the ark;

THE PERIMETER MEASURE OF NOAH'S ARK

The stern and bow of the Ark had a width of 50 cubits each.
The port (left side) and starboard (right side) each were 300 cubits in length.
 $300c + 300c + 50c + 50c = 700$ linear cubits.

1. 700 cubits times the 25.2 inch cubit = $17,640''^*/2520 = 7 \times 2520$
2. 700 cubits times the 21.6 inch cubit = $15,120''/2520 = 6 \times 2520$
3. 700 cubits times the 21 inch cubit = $14,700''/2450 = 6 \times 2450^{**}$
4. 700 cubits times the 18 inch cubit = $12,600''/2520 = 5 \times 2520$
5. 700 cubits times the 17.5 inch cubit = $12,250''/2450 = 5 \times 2450^*$

* “seven times seven” = 17,640 prophetic days or 49 years. A sum found in the Jubilee cycle & other measures.

** Jubilee cycles of 50 years each (607 B.C. to 1844).

Genesis 6:15 - And this is the fashion which thou shalt make it of: The length of the ark shall be three hundred cubits, the breadth of it fifty cubits, and the height of it thirty cubits.

“God gave Noah the *exact dimensions* of the ark and *explicit directions* in regard to its construction in every particular. *Human wisdom could not have devised* a structure of so great strength and durability. God was the designer, and Noah the master builder.

It was constructed like the hull of a ship, that it might float upon the water, but in some respects it more nearly resembled a house.”
Patriarchs and Prophets, p. 92

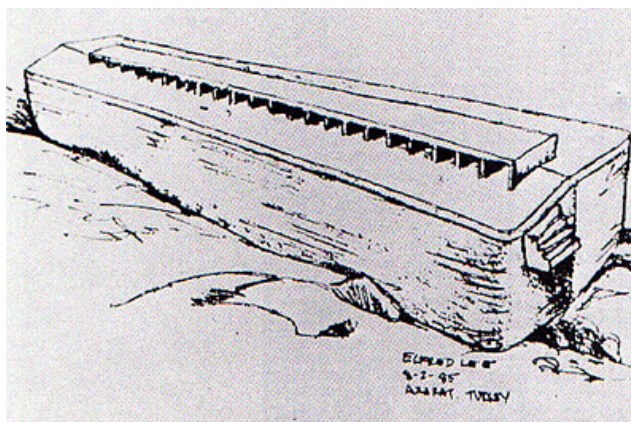

Many ark scholars believe that the ark was a *barge* shape, not a pointed boat shape.

AS IT WAS IN THE DAYS OF NOAH

“The iniquity in Israel during the last half century
before the Assyrian captivity
was like that of the days of Noah,
and of every other age when men have rejected God
and have given themselves wholly to evil-doing.”
Prophets and Kings, p. 281

SO SHALL ALSO THE COMING OF THE SON OF MAN BE

For as in the days that were before the flood they were
eating and drinking, marrying and giving in marriage,
until the day that Noe entered into the ark, And knew not
until the flood came, and took them all away; so shall
also the coming of the Son of man be. Matt. 24:37-39

BELSHAZZAR'S 2520



- In the Chaldean (Babylonian) language this terminology referred to units of monetary value.
- The base unit of Chaldean ancient monetary system was the *gerah*. Twenty of these *gerahs* formed one shekel [or, *tekel*]. One thousand *gerahs* made a *Minah* [or, *Mena/Mina*]. While there was no coin known as a *Peres* or *Upharsin* [the plural of *Peres*], the word meaning *division* was used as we use the word *half* in much the same manner as we refer to a half dollar. It referred to a half *Minah*, being equal to 500 *gerahs*. Treating these words as monetary units, then, we find:

• <i>Mena</i> 1000 (1,000 <i>gerahs</i> = 1 <i>Minah</i> or <i>Mina</i>)	=	1,000	<i>gerahs</i>
<i>Mena</i> 1000 (1,000 <i>gerahs</i> = 1 <i>Minah</i> or <i>Mina</i>)	=	1,000	<i>gerahs</i>
<i>Tekel</i> 20 <i>gerahs</i> (20 <i>gerahs</i> = 1 <i>Shekel</i> * or <i>Tekel</i>)	=	20	<i>gerahs</i>
<i>Upharsin/Peres</i> 500 <i>gerahs</i> (1/2 of a <i>Minah</i>) or 1,000/2	=	<u>500</u>	<i>gerahs</i>
• Total Number of <i>gerahs</i>		2,520	<i>gerahs</i>

(Note: See Numbers 3:47 - 1 shekel = 20 *gerahs*)



"These words are interesting, they are actually Aramaic words. They may have been written in another language but according to Strong's Concordance these words are common Aramaic words. So the king may truly have not been able to read what was written but what is more likely is he was able to read it; he just did not understand what message was behind the words. In verses 26 - 28 Daniel gives the meanings while Strong's Concordance identifies that *Peres* and *Upharsin* are the same word. So *mene, mene, tekel, uparsin* would be literally interpreted "number, number, weight, divide." "Belshazzar saw the number on the wall and he didn't understand what it meant. But when Daniel sees it he realizes right away that this was not a good thing. You see, Daniel understood what the 2520 meant—scattering. He knew it meant God's judgment on the kingdom. That's why he said, 'Your kingdom is weighed and wanting, divided, numbered and finished!'" Quote is from the web site: <http://the.2520.com>

(the.2520@gmail.com, author of this book, is no relation to <http://the.2520.com>)

"These words were spoken by our Instructor:
"Some are reckless, *insensible of the results of sin,*
heedless of warning.

Soon the handwriting on the wall,
now unintelligible to them, will be read.
But it will then be too late for them to repent.
Like Belshazzar, they seem unable to see their peril.

A straight testimony must be borne
to our churches and institutions,
to arouse the sleeping ones."

R&H, November 18, 1902

Belshazzar represents the foolish virgins.



Dan. 5:22
"... thou knewest all this; ..."

"Daniel reviewed the past,
bringing before Belshazzar the
light which he had received
from the history and judgment
of Nebuchadnezzar. ..."

The Bible Echo, Sept. 17, 1894

The "handwriting on the wall" is now intelligible!

WHAT IS THE RESULT OF A STRAIGHT TESTIMONY?

The law of the LORD is perfect, *converting* the soul:
the testimony of the LORD is sure, *making wise* the simple.

The statutes of the LORD are right, *rejoicing the heart*:
the commandment of the LORD is pure, *enlightening the eyes*.

Psalms 19:7-8

"Modern Israel are in greater danger of forgetting God and being led into idolatry than were His ancient people. Many idols are worshiped, even by professed Sabbath keepers. God especially charged His ancient people to guard against idolatry, for if they should be led away from serving the living God, His curse would rest upon them, while if they would love Him with all their heart, with all their soul, and with all their might, He would abundantly bless them in basket and in store, and would remove sickness from the midst of them.

A blessing or a curse is now before the people of God--

a blessing if they come out from the world and are separate, and walk in the path of humble obedience; and *a curse* if they unite with the idolatrous, who trample upon the high claims of heaven. The sins and iniquities of rebellious Israel are recorded and **the picture presented before us as a warning** that if we imitate their example of transgression and depart from God we shall fall as surely as did they. 'Now all these things happened unto them for ensamples: and they are written for our admonition, upon whom the ends of the world are come.'" Testimonies, vol. 1, p. 609

NOTES

CHAPTER 3

THE WILDERNESS TABERNACLE

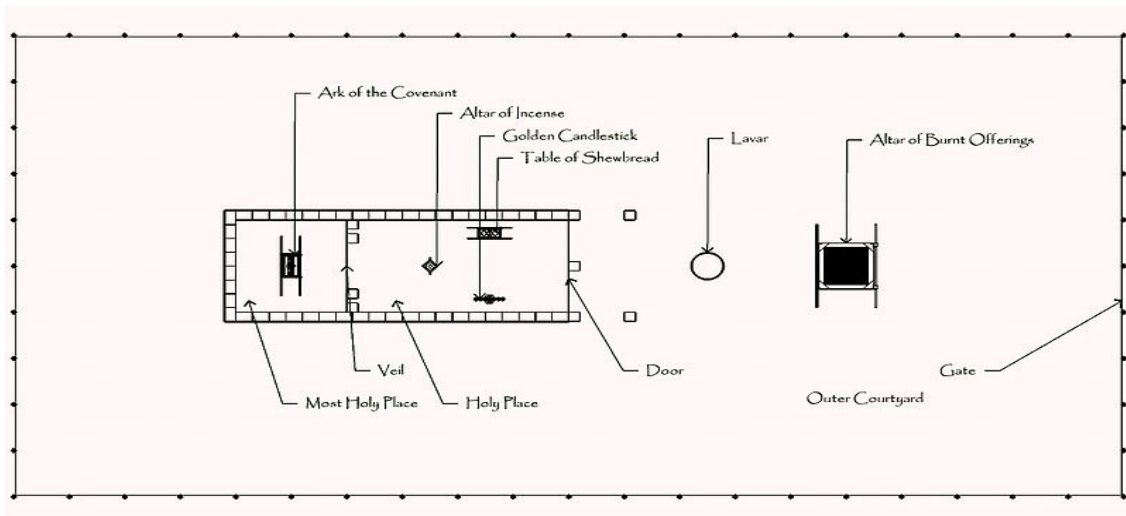

Exodus 25:8

And let them make me a sanctuary;
that I may dwell among them

Part A

HOW IS THE TEMPLE MEASURED?

Answer:

Each article used in the construction of the temples or furniture is built according to a blueprint and has to be measured *before* it is cut and assembled into a finished product.

The Architect is God.
The construction managers were Moses & Solomon.
They built His temples following His blueprint.



Exodus 26-30

THE WILDERNESS TABERNACLE IS MEASURED BY THE 18" CUBIT.



This octagon
will give the
measure using
the
17.5" cubit.

“The long and accurate repetition in the closing part of this book of the details of the construction of the tabernacle *must have had a definite purpose*. ...It also emphasizes the need of exact and strict obedience to the divine commands. ...”

“The *exact correspondence of detail with detail* teaches the lesson that what God commands is to be observed to the letter. ...” *Seventh-day Adventist Commentary*, Vol. 1, p. 681

“... In order that the earthly tabernacle might represent the heavenly, it must be perfect in all its parts, and it must be, in the smallest detail, *like the pattern in the heavens*.”
R&H, January 11, 1912

NOTES

Chapter 3
WILDERNESS TABERNACLE

Part B
THE COURTYARD AND PILLARS

The Courtyard *perimeter* (without veiled entrance) is **2 x 2520**.
 The Courtyard Veil is **360**.

Exodus 27:18 – The length of the court shall be an hundred cubits,
 and the breadth fifty every where, and the height five cubits of fine twined linen.

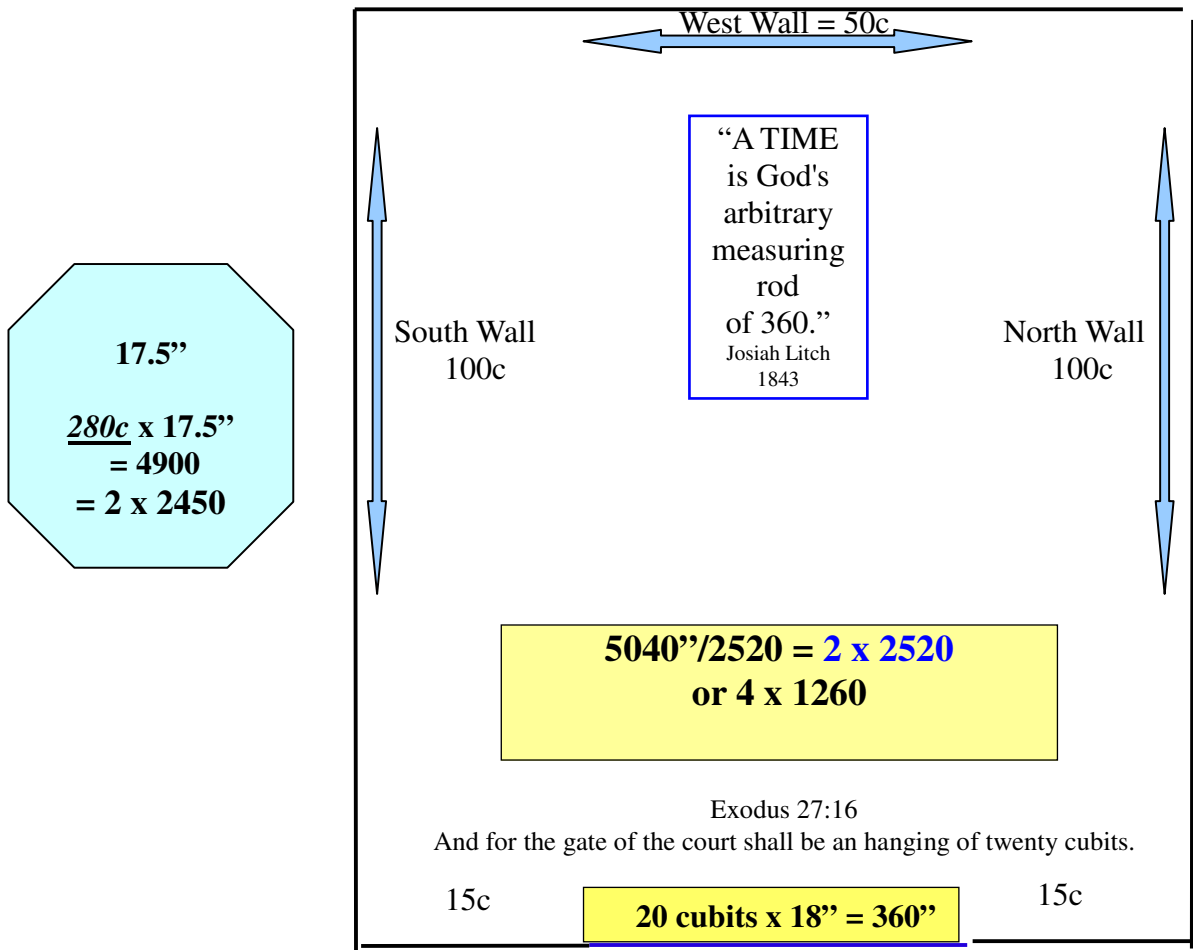

North Wall: 100c
 South Wall: 100c
 West Wall: 50c
 North side of Entrance: 15c
 South side of Entrance: 15c
 Total = **280c x 18'' = 5040''**
 or **2 x 2520**

EXODUS 27:9-18 = 69 PILLARS

60 pillars for the courtyard hangings.

9 pillars for the two veils = **69 pillars**.

At the end of 69 weeks (483 years from 457 B.C. -27 A.D.) Jesus was baptized.

THE 70th PILLAR IS JESUS

“Jesus Christ, enshrouded in the pillar of cloud and fire, was to be their invisible leader, the ruler over all their tribes.”

R&H, Dec. 17, 1895

The 70th week is 27 A.D. - 34 A.D.

“And he shall confirm the covenant with many for one week: ...” Daniel 9:27

The 70th week is 2520 literal days.



Exodus 13:21

And the LORD went before them by day in a pillar of a cloud, to lead them the way; and by night in a pillar of fire, to give them light; to go by day and night:

Exodus 27:9-12

South side = 20 pillars
North side = 20 pillars
West side = 10 pillars
Total pillars = **50**

Exodus 27:14-16 continued:

Gate of East entrance = 4 pillars.
Hangings on south side of gate = 3 pillars.
Hangings on north side of gate = 3 pillars.
Total pillars = **10**

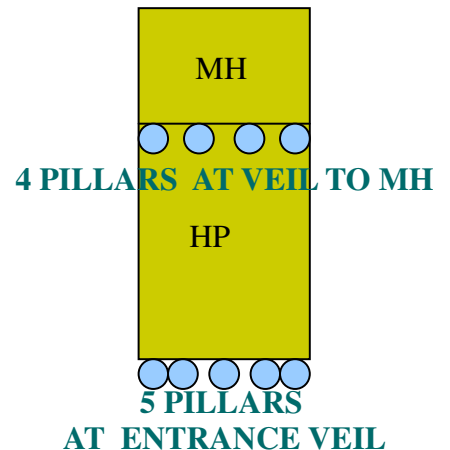
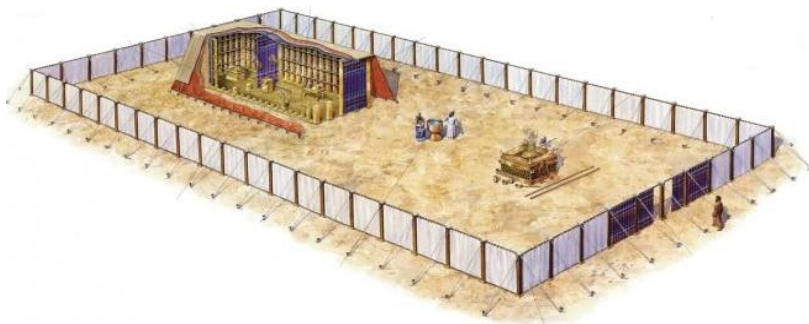

FROM THE COURTYARD GATE
TO THE MOST HOLY VEIL IS **1260''**

PLACEMENT OF TABERNACLE WITHIN COURTYARD

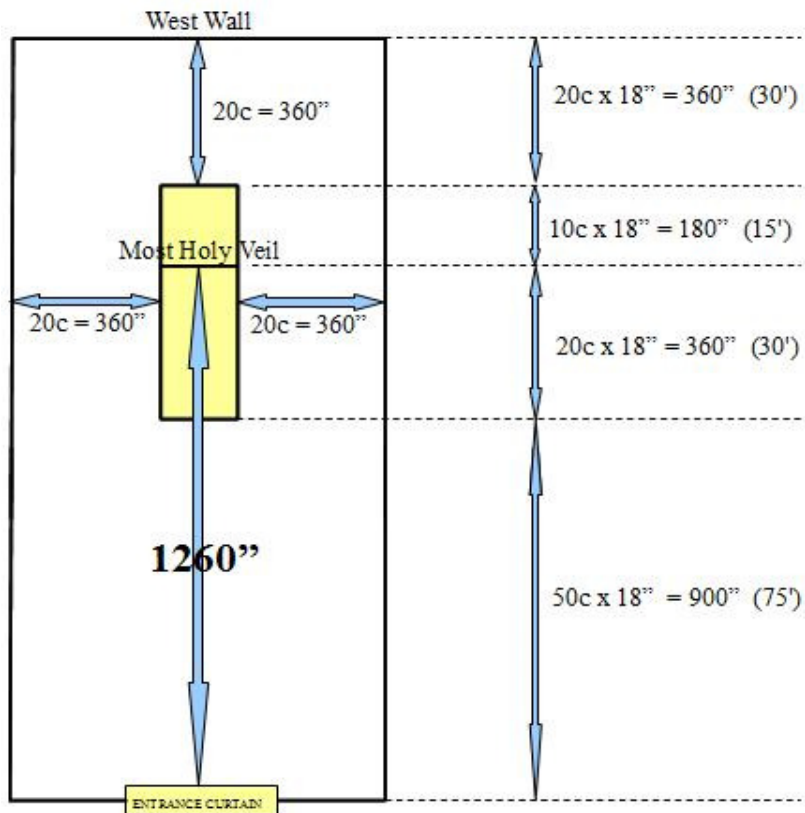

Note: 7 x 1260 in the Bible:

Dan. 7:25 = time (360), times (720), dividing of time (180) = 1260

Dan. 12:7 = time (360), times (720), and an half (180) = 1260

[Daniel's 2 x 1260 = 2520]

Rev. 11:2 = 42 months = 1260 yrs.

Rev. 11:3 = 1260 yrs.

Rev. 12:6 = 1260 yrs.

Rev. 12:14 = time (360), times (720), half a time (180) = 1260

Rev. 13:5 = 42 months = 1260 yrs.

Chapter 3

WILDERNESS TABERNACLE

Part C

THE FOUNDATION SOCKETS MADE OF 96 SILVER TALENTS

Proverbs 10:25

As the whirlwind passeth, so is the wicked no more:
but the righteous is an everlasting foundation.

2 x 144,000

IN THE 96 SILVER SOCKETS (THE FOUNDATION)

12 courses x 24,000 men = 288,000 who served the king

"The men capable of bearing arms and of serving the king were divided into *twelve courses of twenty-four thousand* each. ...The courses. . . came in and went out month by month throughout all the months of the year." Thus every group of *twenty-four* thousand served the king *one month* during each year." {3BC 1128.6}

<p>Proverbs 10: 25 "... but the righteous is an <i>everlasting foundation</i>."</p>	<p>2 Tim. 2:19 - "Nevertheless <i>the foundation</i> of God standeth sure, having this seal, The Lord knoweth them that are his. And, Let every one that nameth the name of Christ depart from iniquity."</p>
---	---

Exodus 26:19-25

And thou shalt make forty sockets of silver under the twenty boards; ...And for the second side of the tabernacle on the north side there shall be twenty boards: And their forty sockets of silver; ... And they shall be eight boards, and their sockets of silver, sixteen sockets;

Exodus 30:11-13

... This they shall give, every one that passeth among them **that are numbered**, half a shekel after the shekel of the sanctuary: (a shekel is twenty gerahs:) an half-shekel shall be the offering of the LORD.

The half-shekel (beq'a) also represents the redeemed and is fused into the silver sockets of each Board.



<p>Exodus 38:27 And of the hundred talents of silver were cast the sockets of the sanctuary, and the sockets of the veil; an hundred sockets of the hundred talents, <u>a talent for a socket</u>. <i>SDABC</i>, vol. 8, p.1087: The Hebrew talent is 3,000 shekels</p>	
<p>48 Boards x 2 sockets each Board = 96 sockets or talents: = 96 x 3,000 shekels = 288,000</p>	<p>48 Boards = Temple *24 Boards = 144,000 *24 Boards = 144,000</p>

"We learn one thing from this passage which has not been so definitely stated before, namely, how many shekels make a talent. Here are [603,550] persons, paying half a shekel each; and the aggregate is [100] talents, and [1,775] shekels. Obviously the number of shekels paid was half of the [603,550] that is, [301,775]. Taking out this, [1,775] the fractional part of the sum given, and we have just three hundred thousand shekels remaining.

These are the one hundred talents making three thousand shekels to one talent."

1867, William Manley, *COMMENTARY ON THE BIBLE*, p. 99.

*These 24 Boards may represent the 24 Elders, the first fruits resurrected from the dead.

*The other 24 Boards might symbolize the 144,000 who are translated without seeing death.

Chapter 3
WILDERNESS TABERNACLE

Part D
THE TABERNACLE BOARDS OF EXODUS 26:15-30

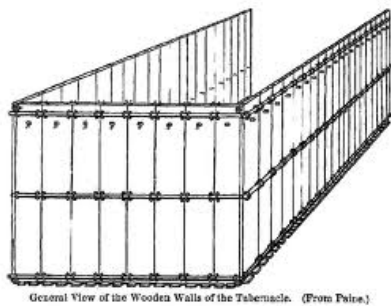

General View of the Wooden Walls of the Tabernacle. (From Poire.)

Some have added the Two Corner Boards to the width of the West Wall making it 12c wide instead of 10c wide.

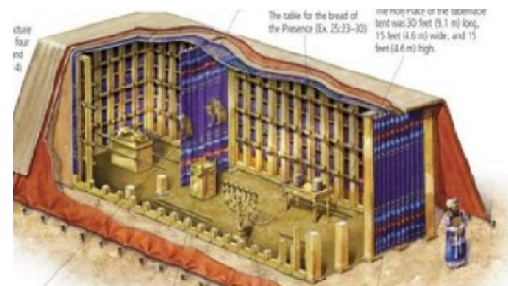

These Boards are positioned sideways.

The Tabernacle frame is made from Boards cut from the Acacia Tree. There are many different opinions as to how the Boards were arranged, especially the Two Corner Boards.

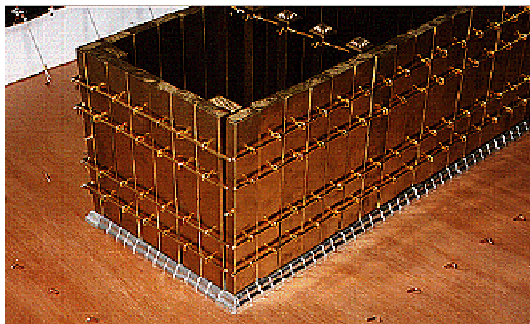

Two Corner Boards on the inside.

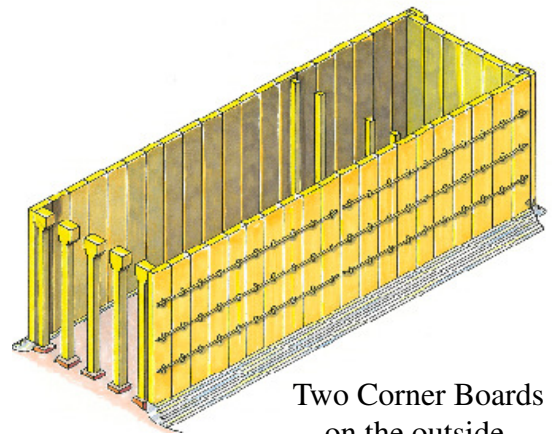

Two Corner Boards on the outside.

Exodus 26:15
 And thou shalt make boards for the tabernacle of shittim [acacia] wood standing up.

The Acacia Tree



“The Acacia is one of the largest species of trees in the world with more than 800 different types growing in warm, tropical and desert-like regions of both hemispheres. ... The Acacia tree's sturdy branches and durable trunk made the species. an invaluable resource for shipbuilder's in the 1700s”

<http://www.2020site.org/trees/acacia.html>

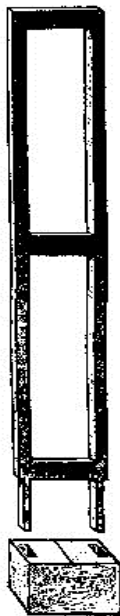

Were the Boards hollow, as on the left?
or solid, as on the right?
No one knows for sure.



48 BOARDS FRAME THE TABERNACLE

Joshua 21:41- All the cities of the Levites within the possession of the children of Israel were *forty and eight* cities with their suburbs.

Exodus 26:18-23

And thou shalt make the boards for the tabernacle, *twenty boards* on the south side southward. And for the second side of the tabernacle on the north side *twenty boards*: And for the sides of the tabernacle westward thou shalt make *six boards*. And two boards shalt thou make for the corners of the tabernacle *in the two sides* [count these two Board with the 40 Boards of the north and south walls].

THE 42 + 6 BOARDS ARE SYMBOLIC OF THE 42 + 6 CITIES

<p style="text-align: center;"><u>42 + 6 CITIES:</u></p> <p style="text-align: center;">Numbers 35:6 (Joshua 21:41)</p> <p>And among the cities which ye shall give unto the Levites there shall be <i>six cities for refuge</i>, which ye shall appoint for the manslayer, that he may flee thither: and to them <i>ye shall add forty and two cities</i>. 35:7 So all the cities which ye shall give to the Levites shall be <i>forty and eight cities</i>: them shall ye give with their suburbs.</p>	<p style="text-align: center;"><i>The Levites were given forty-eight cities</i>, scattered throughout all the twelve tribes, and the tithes were used for their support.</p> <p style="text-align: center;">Thus Jacob's prophecy, was fulfilled; they were "divided in Jacob, and scattered in Israel."</p> <p style="text-align: center;">S.N. Haskell, <i>THE CROSS AND ITS SHADOW</i>, p. 302</p>
---	---

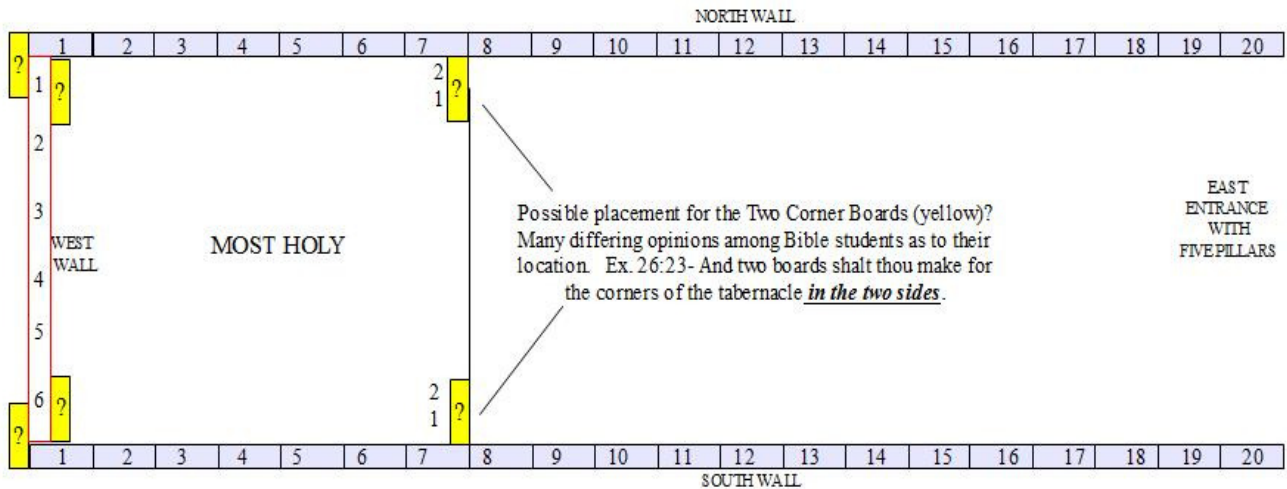

THE LINEAR MEASURES OF THE TOP & BOTTOM WIDTHS OF THE 48 BOARDS OF THE TABERNACLE'S FRAME = **144 LINEAR CUBITS.**

This sum of 144 cubits, is God's signature.

This proves the method of measuring in this work is correct, as the width of the Boards is figured in sums different from the length.

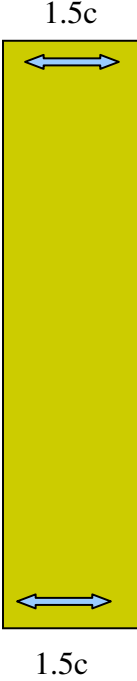

$1.5c + 1.5c = 3c$
 $3c \times 48 \text{ Boards} = 144c$

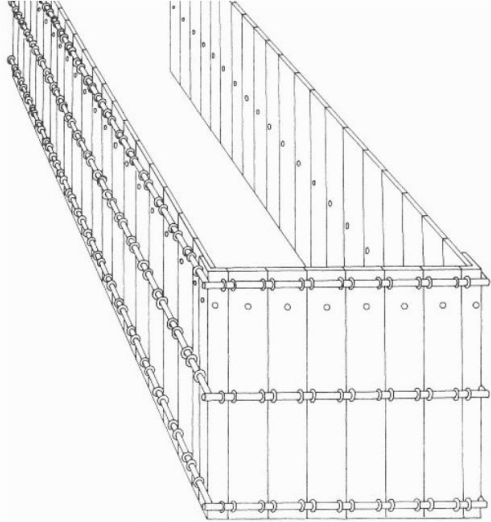

Fig. 4.—Wooden walls of the Tabernacle

MEASURING THE TABERNACLE BOARDS

- v. 15 And thou shalt make boards for the tabernacle of shittim wood standing up.
- v. 16 Ten cubits shall be the length of a board, and a cubit and a half shall be the breadth of one board.
- v. 17 Two tenons shall there be in one board, set in order one against another:
thus shalt thou make for all the boards of the tabernacle.
- v. 18 And thou shalt make the boards for the tabernacle, twenty boards on the south side southward.
- v. 19 And thou shalt make forty sockets of silver under the twenty boards; two sockets under one board for his two tenons ...
- v. 20 And for the second side of the tabernacle on the north side there shall be twenty boards: And their forty sockets of silver;
- v. 22 And for the sides of the tabernacle westward thou shalt make six boards.
- v. 23 And two boards shalt thou make for the corners of the tabernacle in the two sides.
- v. 25 And they shall be eight boards, and their sockets of silver, sixteen sockets; two sockets under one board, ...

IMPORTANT REMINDER:

Before any object can be built or manufactured a blueprint/pattern must be drawn. THEN, the parts to the objects are measured and cut to the right size. All measuring in this work is done with this principle. All four edges of a Board (or fabric) used in building the Tabernacle is measured ***BEFORE*** it is cut or assembled to the right size.

IMPORTANT
POINT!

The measures of the height and width of the Boards are applied to separate applications. There are two measures for each Board: one for the top & bottom width ($1.5c + 1.5c = 3c$), and one for the combined height of each edge. ($10c + 10c = 20c$).

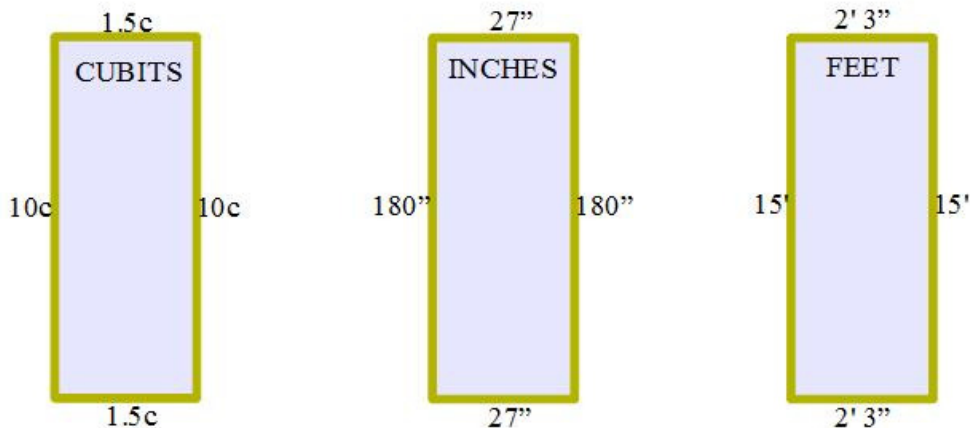

Example using feet: 15' for each side of a Board x 2 sides = 30' x 42 Boards = 1260'
(The north & south Boards are figured separate from the west Boards.)

THE PERIMETER OF THE TWO CORNER BOARDS = 46 CUBITS

1. God singled out these two Boards out for our attention. EXODUS 26:23 “And two boards shalt thou make for the corners of the tabernacle *in the two sides.*”
2. Notice: “*in the two sides*”. These two Boards are added to the 40 Boards of the north and south walls making a total of 42 Boards (west wall's 6 Boards figure in other measures).
3. In our human cells we have 23 pairs of chromosomes for a total of 46.
4. Each Corner Board has 23 cubits perimeter. Two Boards have 46 cubits.

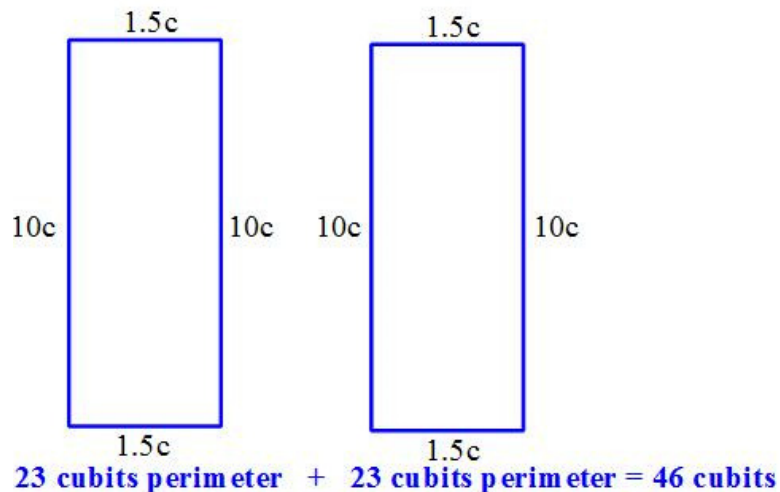

46 YEARS between fall of northern kingdom (723 B.C.) and fall of southern kingdom (677 B.C.).

46 YEARS to build Herod's temple:

John 2:20 “... forty and six years was this temple [Herod's] in building ...”

46 YEARS from the fall of the Papacy (1798) to the anti-typical *Day of Atonement* and the *Great Jubilee* (1844).

46 JUBILEE CYCLES (2300 years) from the Third Decree to the Third Angel – 457 B.C. to 1844

46 DAYS – Exodus 24:15-18

And Moses went up into the mount...six days ... and the seventh day he called Moses out.

And Moses went into the midst of the cloud, and gat him up into the mount;

And Moses was in the mount forty days and forty nights.

40 NORTH & SOUTH BOARDS + THE 2 CORNER BOARDS

= 6 x 2520

(see page 19 where the 42 years of man's part of the Jubilee cycle = 15,120 or 6 x 2520)

Exodus 26:18, 20, 22

v. 18 And thou shalt make the boards for the tabernacle, twenty boards on the south side southward.

v. 20 And for the second side of the tabernacle on the north side twenty boards:

v. 22 And two boards shalt thou make for the corners of the tabernacle in the two sides.

20c per Board x 18" = 360"
 360" x 42 Boards = 15,120"

Divide 15,120" by 2520"
= 6 x 2520 linear inches

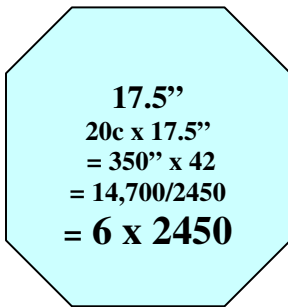
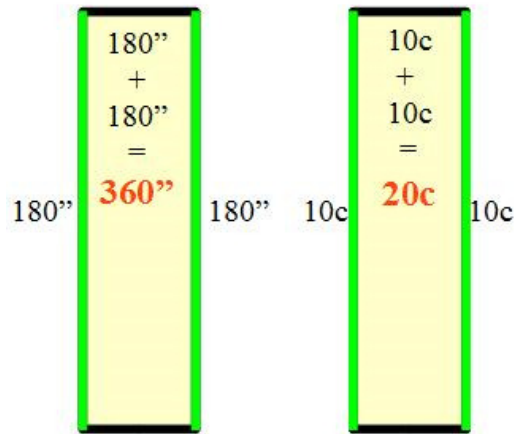

For this 6 x 2520 measure the length of the two long edges
 (10c + 10c = 20c x 18" = 360")
 The width measure will be used for another 2520.

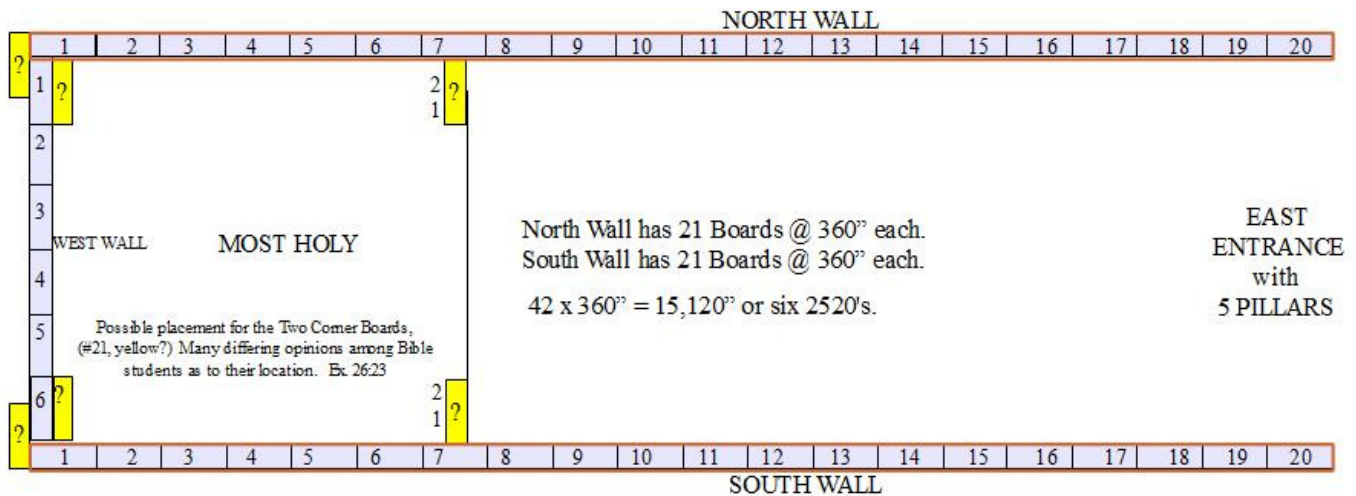

HOW TO MEASURE THE WEST WALL EXODUS 26:22-23

**And for the sides of the tabernacle
westward thou shalt make six boards.**

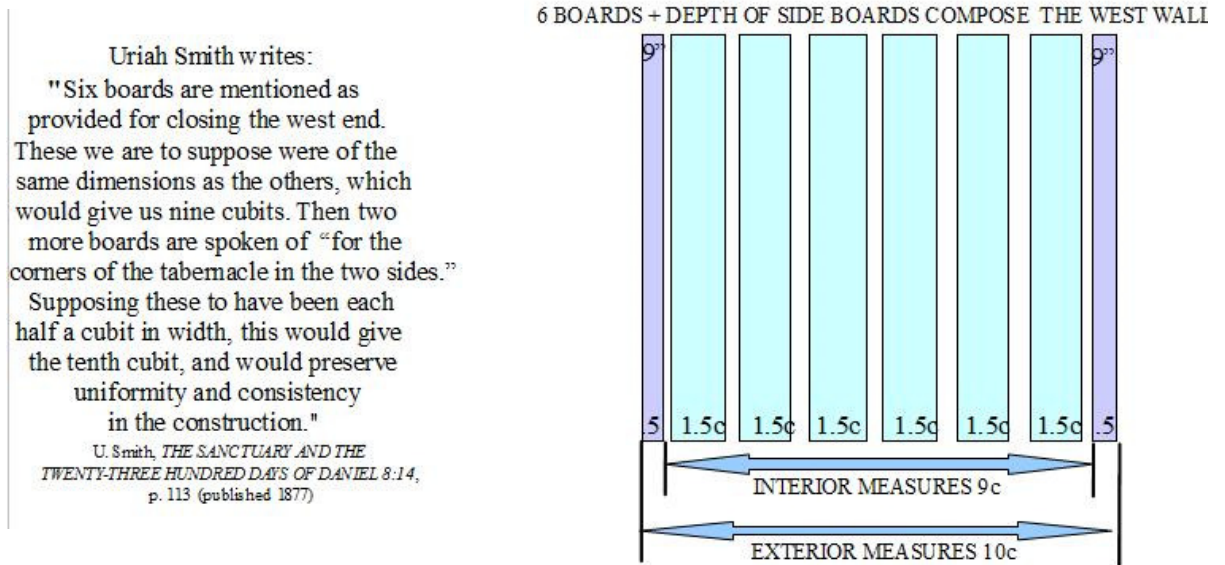

The Goat's Hair Curtain gives us the exact height & width of the Tabernacle.

The Goat's Hair Curtain is 30 cubits in width and this covers the 10 cubit height of the South Wall, the 10 cubit height of the North Wall and the 10 CUBITS WIDTH across the top of the Tabernacle.

But! The six Boards are only 9 cubits in width while the width of the Tabernacle is 10 cubits!

The thickness of the Boards must be 9" (½ cubit or .5) and when the North and South Boards, each with ½ cubit of thickness are butted up next to the West Wall, it adds an extra cubit (18") making it a perfect 10 cubits. Many commentators have different opinions of the thickness of the Boards but this one cubit added to the West Wall makes it perfectly fit the measurements of the Goat's Hair Curtain.

Note: If the two Corner Boards were added to the six Boards of the West Wall this would make the exterior width of the Tabernacle 12 cubits instead of 10.

HEIGHT OF WEST WALL = $14 \times 10c = 140c \times 18'' = 2520$

EXODUS 26:22-23

And for the sides of the tabernacle westward thou shalt make six boards.

Is.45:6

That they may know from the rising of the sun, and from the west, that there is none beside me. I am the LORD, and there is none else.

Is. 59:19

So shall they fear the name of the LORD from the west, and his glory from the rising of the sun.

Thickness of the side Boards.

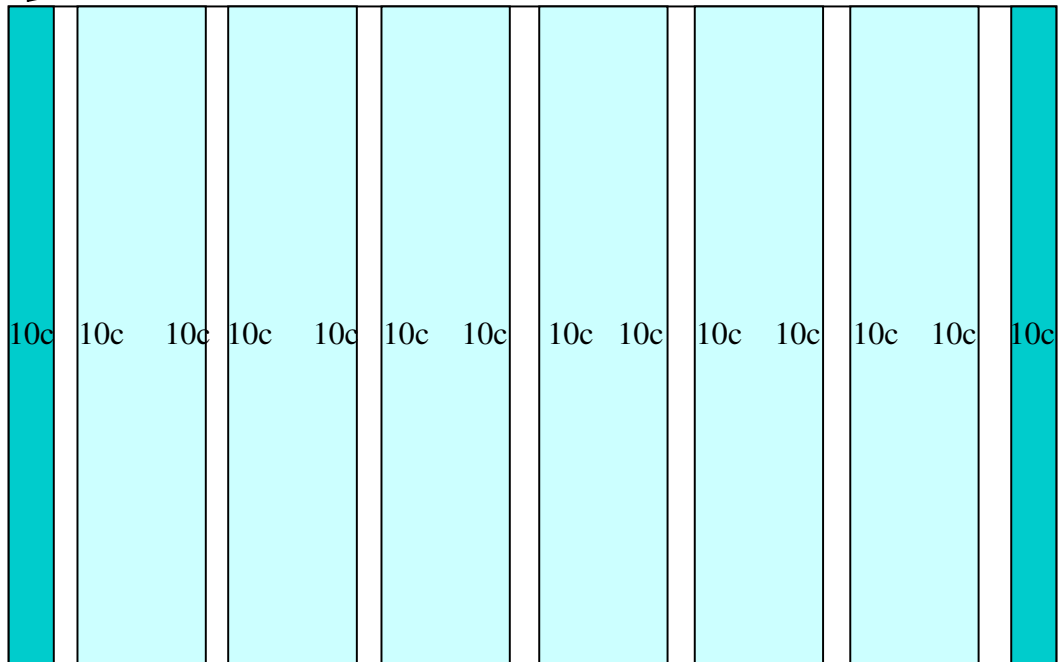

The Boards above are separated in order to demonstrate their measures. Otherwise the west wall is a perfect 10 x 10 square.

17.5''
This wall
also has
the 2450:
140c x 17.5''
= 2450''

MEASURING THE PERIMETER AROUND THE FRAME

(NOTE: THE TWO CORNER BOARDS ARE INSIDE AND ARE NOT MEASURED)

$$140 \text{ cubits} \times 18'' = 2520$$

Exodus 26:15-16 And thou shalt make boards for the tabernacle of shittim wood standing up. Ten cubits shall be the length of a board, and a cubit and a half shall be the breadth of one board

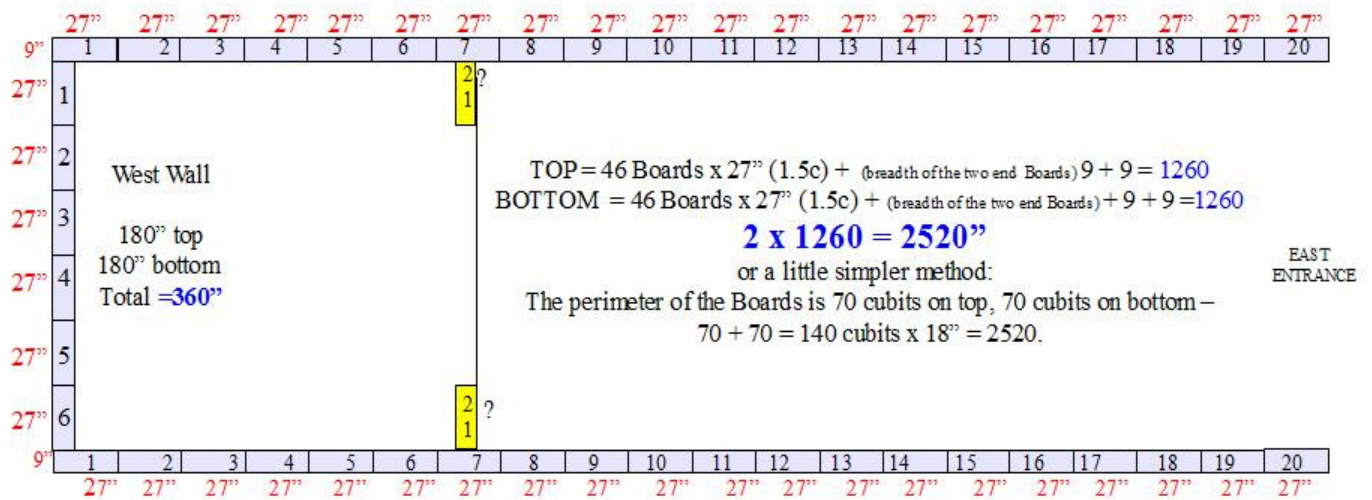
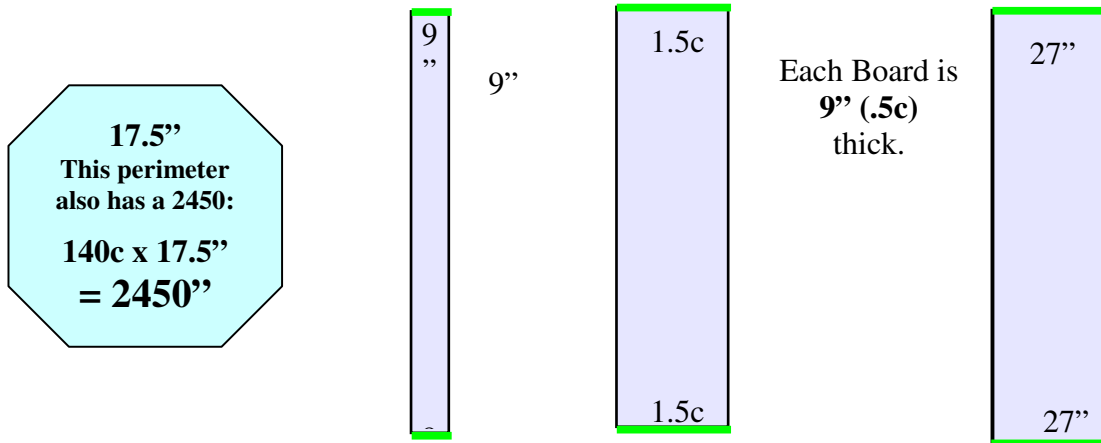

NOTES

EXTRAS

MATT. 8:16

But if he will not hear thee, then take with thee one or two more,
that in the mouth of two or three witnesses every word may be established.

MEASURING THE 48 BOARDS
 WITH THE LINEAR 21" CUBIT
 = 8 x 2520

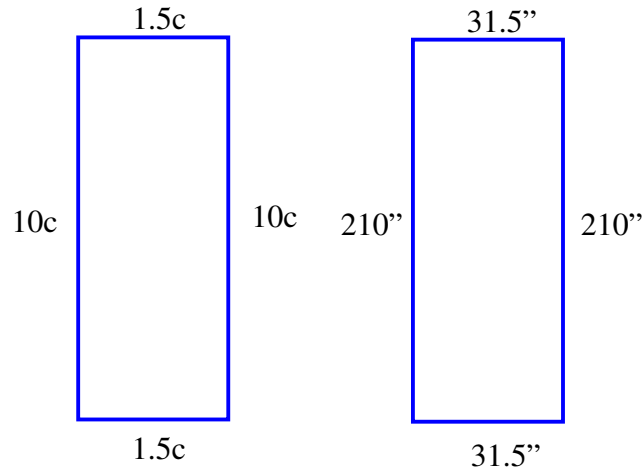

LENGTH OF THE TWO LONG EDGES: $10c \times 21'' = 210''$ $2 \times 210'' = 420''$ $48 \text{ Boards} \times 420'' = 20,160''$ $20,160'' \text{ divided by}$ $2520'' = 8 \times 2520$	WIDTH AT THE TOP & BOTTOM $31.5'' + 31.5'' = 63''$ $48 \text{ Boards} \times 63'' = 3024''$ $3024 \text{ divided by } 144''$ $= 21''$
---	--

Note:

The square cubit of one Board is $1.5c \times 10c = 15sc$
 $15sc \times 48 \text{ Boards} = 720sc$.

720 is the "TIMES" (2 x 360) of Dan. 7:25, 12:7, Rev. 12:14.

MEASURING THE 48 BOARDS
 WITH THE LINEAR 21.6" CUBIT
 = **144 x 144**

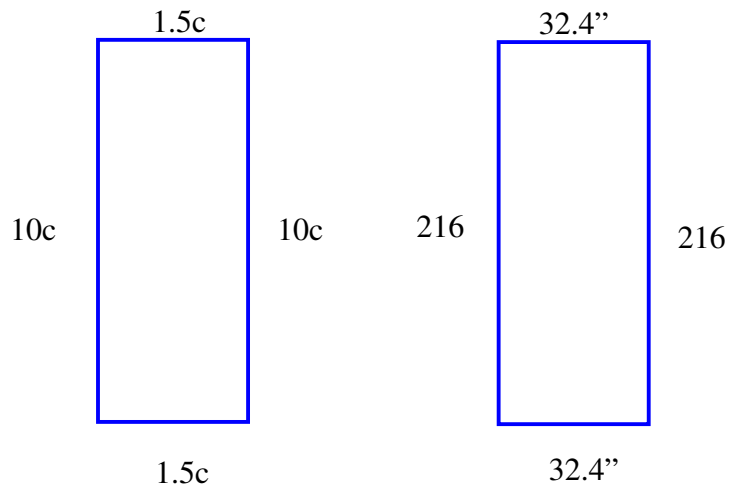

<p>LENGTH OF THE TWO LONG EDGES:</p> <p>$10c \times 21.6 = 216''$ $2 \times 216'' = 432''$</p> <p>$48 \text{ Boards} \times 432''$ $= 20,736''$</p> <p>$20,736''$ divided by $144''$ $= \mathbf{144 \times 144}$</p>	<p>WIDTH AT THE TOP & BOTTOM</p> <p>$32.4'' + 32.4'' = 64.8''$</p> <p>$48 \text{ Boards} \times 64.8''$ $= 3110.04''$</p> <p>3110.4 divided by $144''$ $= \mathbf{21.6''}$</p>
--	--

MEASURING 40 BOARDS WITH
 THE LINEAR 25.2" CUBIT
= 8 x 2520

MEASURING 8 BOARDS
 WITH THE 25.2" CUBIT
= 28 x 144

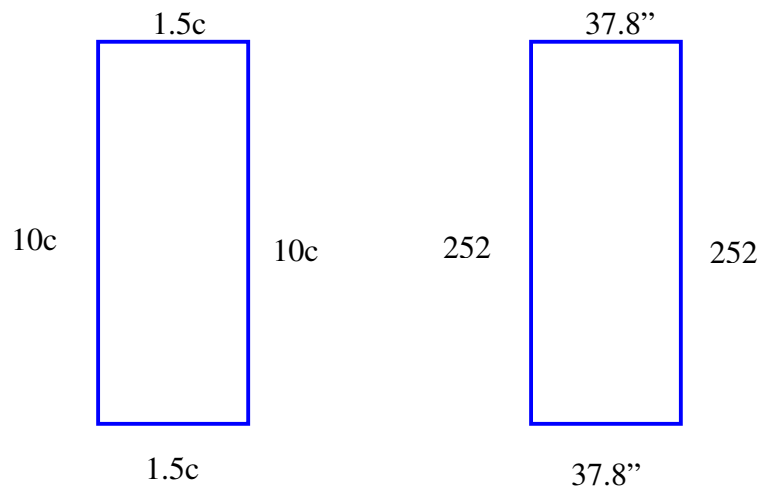

<p>LENGTH OF THE TWO LONG EDGES: $10c \times 25.2 = 252''$ $2 \times 252'' = \underline{504''}$</p> <p>$40 \text{ Boards} \times 504'' = 20,160''$ $20,160'' \text{ divided by } 2520'' = \mathbf{8 \times 2520}$</p> <p>$8 \text{ Boards} \times 504'' = 4032''$ $4032'' \text{ divided by } 144'' = \mathbf{28 \times 144}$</p>	<p>WIDTH AT TOP & BOTTOM $37.8'' + 37.8'' = 75.6''$</p> <p>$48 \text{ Boards} \times 75.6'' = 3628.84''$ $\text{divided by } 144'' = 25.2''$</p>
---	---

Note:
504'' is the length in inches of the Linen Curtain by the 18'' cubit.
 $\underline{504} \times 5 = \mathbf{2520}$; $\underline{504}/126 = 4$

Chapter 3

WILDERNESS TABERNACLE

Part E

THE LINEN CURTAIN

The building was divided into two apartments by a rich and beautiful curtain, or veil, suspended from gold-plated pillars; and a similar veil closed the entrance of the first apartment. These, *like the inner covering, which formed the ceiling*, were of the most gorgeous colors, blue, purple, and scarlet, beautifully arranged, while inwrought with threads of gold and silver were cherubim to represent the angelic host who are connected with the work of the heavenly sanctuary and who are ministering spirits to the people of God on earth.

Ellen G. White, *Patriarchs and Prophets*, p. 347

THE LINEN COVERING IS MADE OF TEN CURTAINS

EXODUS 26:1-3

Moreover thou shalt make the tabernacle with **ten curtains** of fine twined linen, and *blue, and purple, and scarlet*: with cherubims of cunning work shalt thou make them. The length of one curtain shall be *eight and twenty cubits*, and the breadth of one curtain *four cubits*: and every one of the curtains shall have one measure. The *five curtains shall be coupled together* one to another; and *other five curtains shall be coupled* one to another.



MATT. 25:1

Then shall the kingdom of heaven be likened unto *ten* virgins, which took their lamps, and went forth to meet the bridegroom.

25:2 And *five* of them were wise, and *five* were foolish.



THE 5 WISE VIRGINS

Here is the patience of the saints, here are they that keep the commandments of God, and the faith of Jesus.

Rev. 14:12

THE 5 FOOLISH

“Some have been and are still, refusing to put on the wedding garment. They still wear their citizen's dress, and despise the garment woven in the loom of heaven, which is, Christ our Righteousness.”

Ellen G. White, 1888 Materials, p. 1483

"I am often referred to the parable of the ten virgins, five of whom were wise, and five foolish. This parable has been and will be fulfilled to the very letter, for it has a special application to this time, and, like the third angel's message, has been fulfilled and will continue to be present truth till the close of time."

R&H, August 19, 1890

THE LINEN CURTAIN HAS 2520 SQ. FT.

Exodus 26:1-3 -- The length of one curtain shall be eight and twenty cubits, and the breadth of one curtain four cubits:

$$40 \text{ cubits} \times 28 \text{ cubits} = 1120 \text{ sq. cubits}$$

$$1120 \text{sc} \times 324 \text{ sq. in.} = 362,880 \text{ sq. in.}$$

(324 is the square measure of 18" x 18").

362,880 sq. in. divided by **144** sq. in. = **2520 sq. ft.**

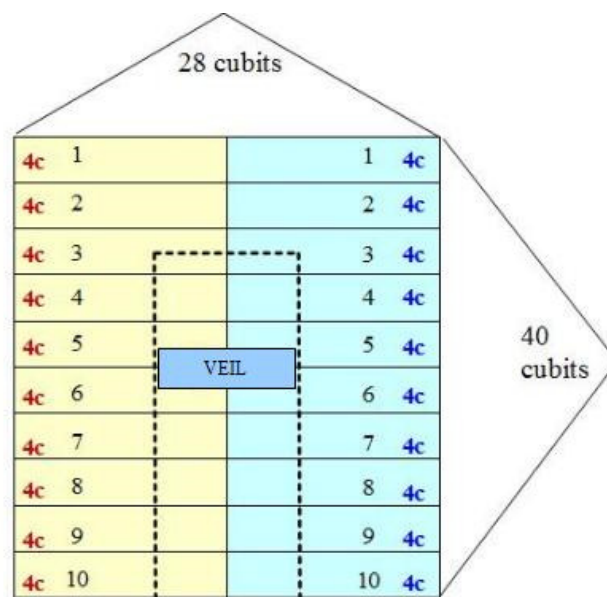

Rev. 7:4

And I heard the number of them which were sealed: and there were sealed an hundred and forty and four thousand of all the tribes of the children of Israel.

Rev. 14:1

And I looked, and, lo, a Lamb stood on the mount Sion, and with him an hundred forty and four thousand, having his Father's name written in their foreheads.

THE EAST & WEST EDGES OF THE LINEN CURTAIN

= 4 x 2520 & 4 x 2450

Exodus 26:1-3

The length of one curtain shall be *eight and twenty cubits*,
and the breadth of one curtain *four cubits*:

Matthew 8:11

And I say unto you, That many shall come *from the east and west*,
and shall sit down with Abraham, and Isaac, and Jacob, in the kingdom of heaven.

ONE SHEET 18" CUBIT

28c x 18" = 504" WEST EDGE

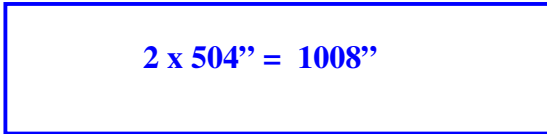

28c x 18" = 504" EAST EDGE

ONE SHEET 17.5" CUBIT

28c x 17.5" = 490" WEST EDGE

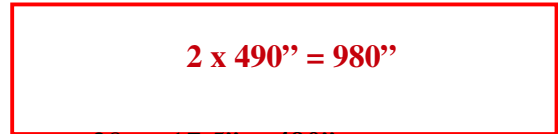

28c x 17.5" = 490" EAST EDGE

17.5" cubit:
See figures
above.
17.5" x 28c =
490

10 sheets x 1008" = 10,080"
10,080/2520 = 4 x 2520

10 sheets x 980" = 9800"
9800/2450 = 4 x 2450

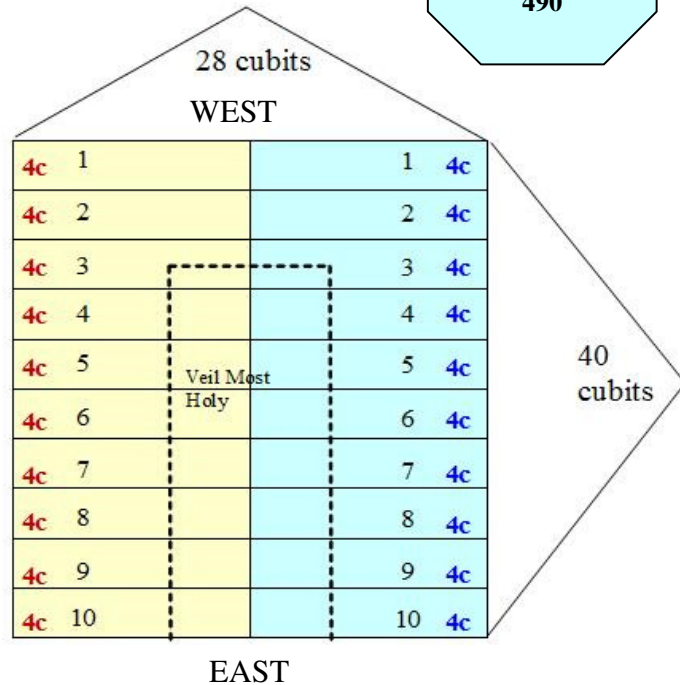

THE NORTH & SOUTH EDGES OF THE LINEN CURTAIN = 10 x 144

Ex. 26:1-3

The length of one curtain shall be *eight and twenty cubits*,
and the breadth of one curtain *four cubits*:

4c x 18" = 72" S

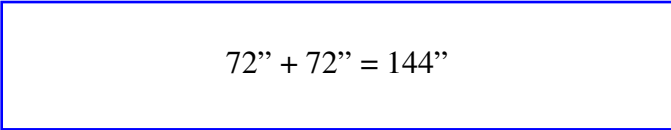

N 4c x 18" = 72"



FIVE FOOLISH VIRGINS



FIVE WISE VIRGINS

SOUTH
40c breadth x 18" = 720"
720" divided by 144" = **5**

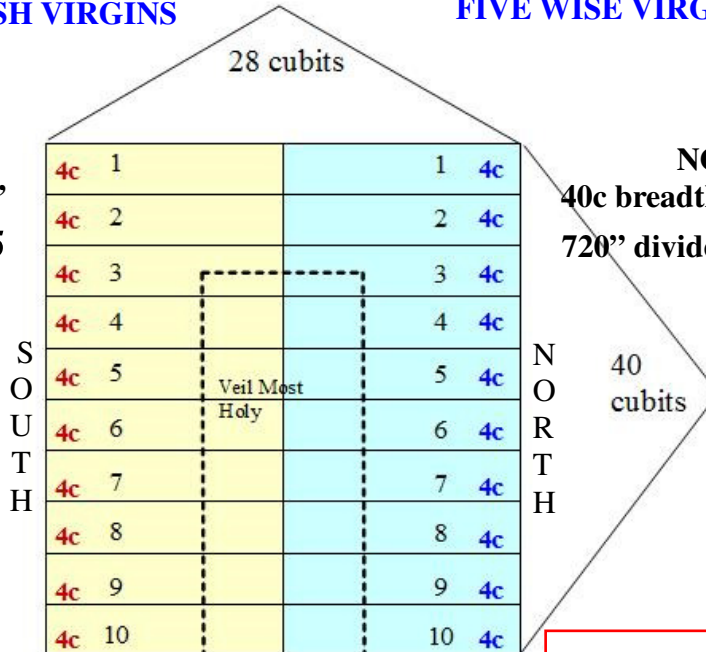

NORTH
40c breadth x 18" = 720"
720" divided by 144" = **5**

Note:
10 x 72" = 720" North = 2 x 360"
10 x 72" = 720" South = 2 x 360"
= 4 x 360"

**THE EAST & WEST EDGES
OF THE LINEN CURTAIN
= 70 x 144**

**Matthew 24:27 For as the lightning cometh
out of the east, and shineth even unto the west;
so shall also the coming of the Son of man be.**

<p>1844 -- <u>first</u> vision given to E.G. White: Portland, Maine – EAST “... the first vision was given to me. There were but five of us, all women, kneeling quietly in the morning at the family altar, when this event transpired. I related this vision to the believers in Portland ...” Ellen White, <i>Life Sketches</i>, p. 193</p>	<p>40 years later, 1884, her <u>last</u> open vision: Portland, Oregon – WEST “Her last open vision was in 1884, on the camp ground at Portland, Oregon.” John Loughborough, <i>General Conference Daily Bulletin</i>, Jan. 29, 1893</p>
--	--

WEST = 28c x 18” = 504”

ONE SHEET = 2 x 504” = 1008”

EAST = 28c x 18” = 504”

10 sheets x 1008” = 10,080”
10,080 divided by 144 = **70 x 144**

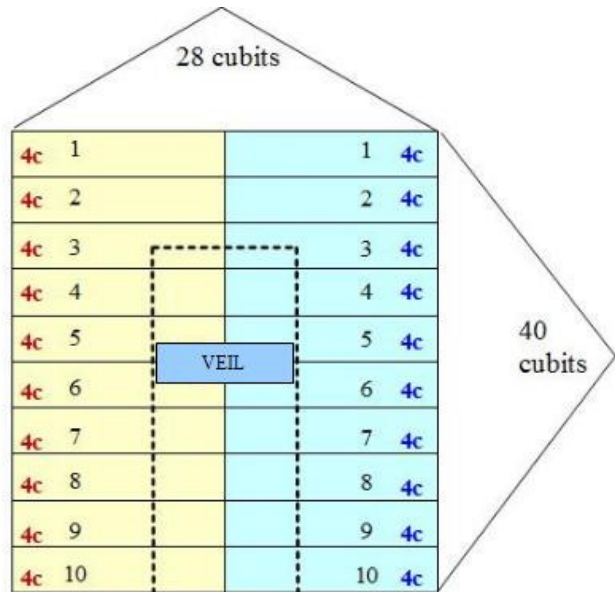

THE PERIMETER OF
EACH SHEET = 8 x 144

Ex. 26:1-3

The length of one curtain shall be eight and twenty cubits,
and the breadth of one curtain four cubits:

ONE SHEET

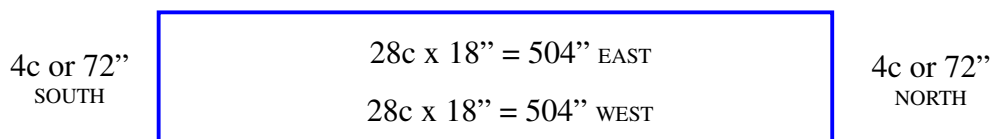

$$504'' + 504'' + 72'' + 72'' = 1152''$$

$$1152/144 = 8$$

Exodus 22:30 Likewise shalt thou do with thine oxen, and with thy sheep:
seven days it shall be with his dam; on the eighth day thou shalt give it me.

THE NUMBER EIGHT REPRESENTS NEW LIFE – RESURRECTION

<p style="text-align: center;">Lev. 23:36</p> <p>Seven days ye shall offer an offering made by fire unto the LORD: on the eighth day shall be an holy convocation unto you; and ye shall offer an offering made by fire unto the LORD: it is a solemn assembly; and ye shall do no servile work therein.</p> <p style="text-align: center;">Ezekiel 43:27</p> <p>And when these days are expired, it shall be, that upon the eighth day, and so forward, the priests shall make your burnt offerings upon the altar, and your peace offerings; <u>and I will accept you</u>, saith the Lord GOD.</p> <p style="text-align: center;">Nehemiah 8:18</p> <p>...and on the eighth day was a solemn assembly, according unto the manner.</p>	<p style="text-align: center;">Lev. 22:27</p> <p>...from the eighth day and thenceforth it shall be accepted for an offering made by fire unto the LORD.</p> <p style="text-align: center;">Numbers 29:35</p> <p>On the eighth day ye shall have a solemn assembly: ye shall do no servile work therein:</p> <p style="text-align: center;">2 Chron. 29:17</p> <p>...so they sanctified the house of the LORD in eight days;</p> <p style="text-align: center;">Acts 7:8</p> <p>And he gave him the covenant of circumcision: and so Abraham begat Isaac, and circumcised him the eighth day;</p>
--	--

2 Chron. 29:17 “... so they sanctified the house of the LORD in eight days;”

The **LINEN COVERING** of the TABERNACLE
and the **LINEN HANGINGS** of the COURTYARD
= 2520 SQUARE CUBITS

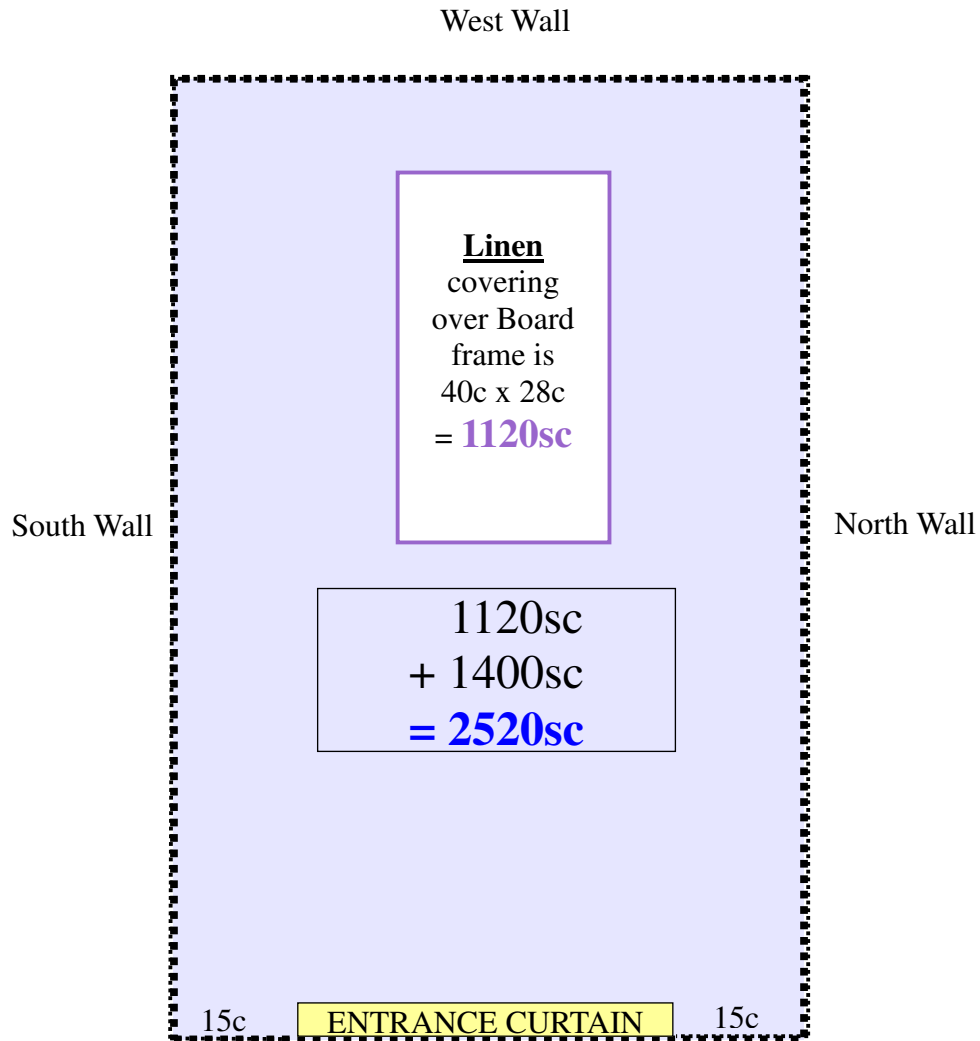

LINEN HANGINGS OF COURTYARD
(excludes Gate)

100c x 5c = 500sc North Wall
100c x 5c = 500sc South Wall
50c x 5c = 250sc West Wall
15c x 5c = 75sc x 2 sides of gate = 150sc
Total = **1400sc**

Chapter 3

WILDERNESS TABERNACLE

Part F

THE GOAT'S HAIR CURTAIN

Ex 36:14-34

“The shelter and special protection that the church is under are signified by the curtains of hair-cloth, which were spread over the tabernacle, and the covering of rams' skins and badgers' skins over them, v. 14-19.”

From Matthew Henry's Commentary

THE GOAT'S HAIR CURTAIN

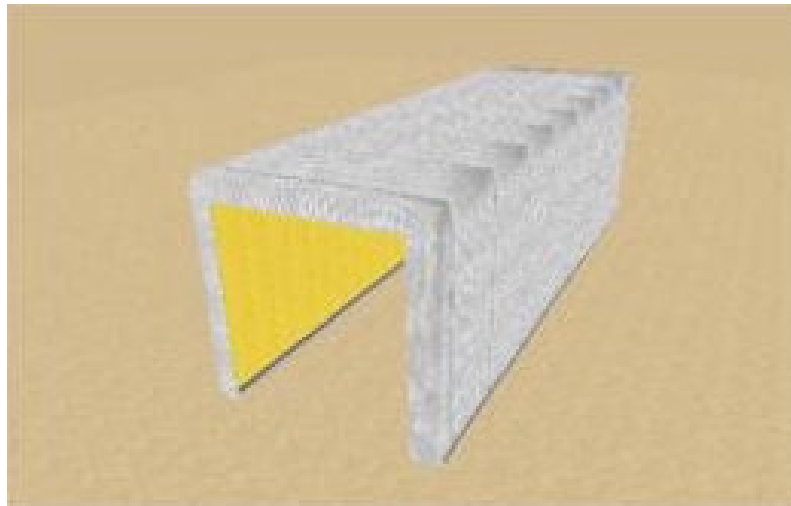

EXODUS 26:7-13

And thou shalt make curtains of goats' hair **to be a covering upon the tabernacle:** eleven curtains shalt thou make. The *length of one curtain thirty cubits*, and the *breadth of one curtain four cubits*: and the eleven curtains all of one measure. And thou shalt couple five curtains by themselves, and six curtains by themselves, and shalt **double** the sixth curtain in the forefront of the tabernacle. And a cubit on the one side, and a cubit on the other side of that which remaineth in the length of the curtains of the tent, it shall hang over the sides of the tabernacle on this side and on that side to cover it.

GOAT'S HAIR CURTAIN 2

THE PERIMETER OF 10 SHEETS
 = **2520 LINEAR INCHES**

Ex. 26:7-13

The length of one curtain thirty cubits,
 and the breadth of one curtain four cubits:

17.5"
 140c x 17.5"
 = 2450

West edge -----30c
 North edge ----40c
 East edge -----30c
 South edge-----40c
 Total = **140 cubits**
140c x 18" = 2520

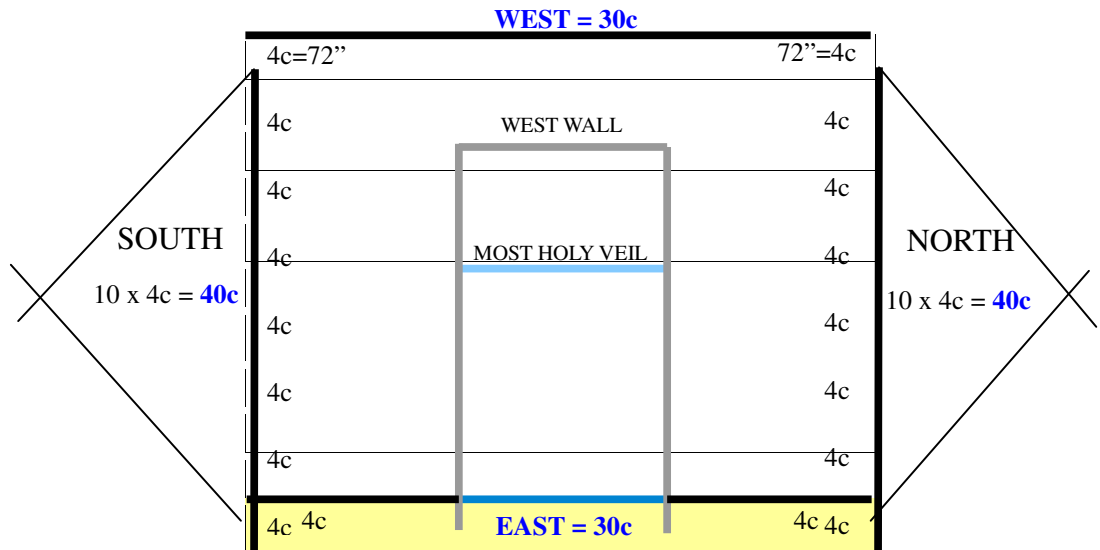

11th sheet (yellow) *hangs over*
 the front of the Tabernacle
 (as a porch or valance) and **IS NOT**
 included in this perimeter measurement..

GOAT'S HAIR CURTAIN 3

SQUARE CUBITS OF 10.5 SHEETS
= 1260 SQUARE CUBITS

Ex. 26:7-13

The length of one curtain thirty cubits,
 and the breadth of one curtain four cubits:

$30c \times 42c = \mathbf{1260 \text{ square cubits}}$
--

WEST EDGE = 30 CUBITS		
4c	4c	
8c	8c	
12c	12c	
16c	16c	
20c	20c	
24c	24c	
28c	28c	
32c	32c	
36c	36c	
40c	40c	10.00 or 40 cubits
41c	41c	10.25 or 41 cubits
42c	EAST = 30 CUBITS	42c 10.5 or 42 cubits
43c	<small>This two cubits is doubled under first two cubits.</small>	43c 10.75 or 43 cubits
44c		44c 11 or 44 cubits



GOAT'S HAIR CURTAIN 4

PERIMETER OF 10.5 SHEETS = **144 LINEAR CUBITS**

Ex. 26:7-13

The length of one curtain thirty cubits,
and the breadth of one curtain four cubits:

17.5" cubit:
144c x 17.5"
= 2520

PERIMETER
West edge -----30c
North edge ----42c
East edge -----30c
South edge-----42c
Total = 144c

WEST EDGE = 30 CUBITS		
4c	4c	
8c	8c	
12c	12c	
16c	16c	
20c	20c	
24c	24c	
28c	28c	
32c	32c	
36c	36c	
40c	40c	10.00 or 40 cubits
41c	41c	10.25 or 41 cubits
42c	42c	10.5 or 42 cubits
EAST = 30 CUBITS		
43c	43c	10.75 or 43 cubits
44c	44c	11 or 44 cubits

This two cubits is doubled under first two cubits.

The 48 Boards on page 38
also have 144 linear cubits.

NOTES

Chapter 3
WILDERNESS TABERNACLE

Part G
The Breastplate of the High Priest
& Most Holy Place

9 x 9
81 square cubits.
81 square inches.

THE BREASTPLATE OF THE HIGH PRIEST
= 81 SQUARE INCHES
(9" x 9")

Exodus 28:15-16

And thou shalt make the **breastplate of judgment** with cunning work; after the work of the ephod thou shalt make it; of gold, of blue, and of purple, and of scarlet, and of fine twined linen, shalt thou make it. ***Foursquare*** it shall be being doubled; ***a span shall be the length*** thereof, and ***a span shall be the breadth*** thereof.



A SPAN = one-half cubit or 9”.

This measure for the Breastplate is the only measure given for the High Priest's garments.

Ephesians 6:14

Stand therefore, having your loins girt about with truth,
and having on the breastplate of righteousness;

“Here was the breastplate of the high priest, set with precious stones, from which messages from Jehovah were received.”

Ellen White, *Signs of the Times*, June 3, 1886

THE INTERIOR OF THE MOST HOLY = 81 SQUARE CUBITS (9c x 9c).

Each Board is 1.5 cubits in width and .5 cubits in thickness.

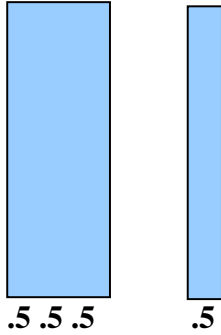

Which side of the pillars was the Veil hung from?
The pillars have to be a minimum of 1/2 cubit thick by 3/4 cubit in width, for we know each Pillar has one silver socket of one talent (Ex. 38:27).

The pillars must take up the space from the 9.5 cubit line to the 10 cubit line with the Veil hanging in front of the pillars positioned exactly under the taches which are at the 10 cubit line. Most pictures show just the opposite with the pillars in front of the Veil.

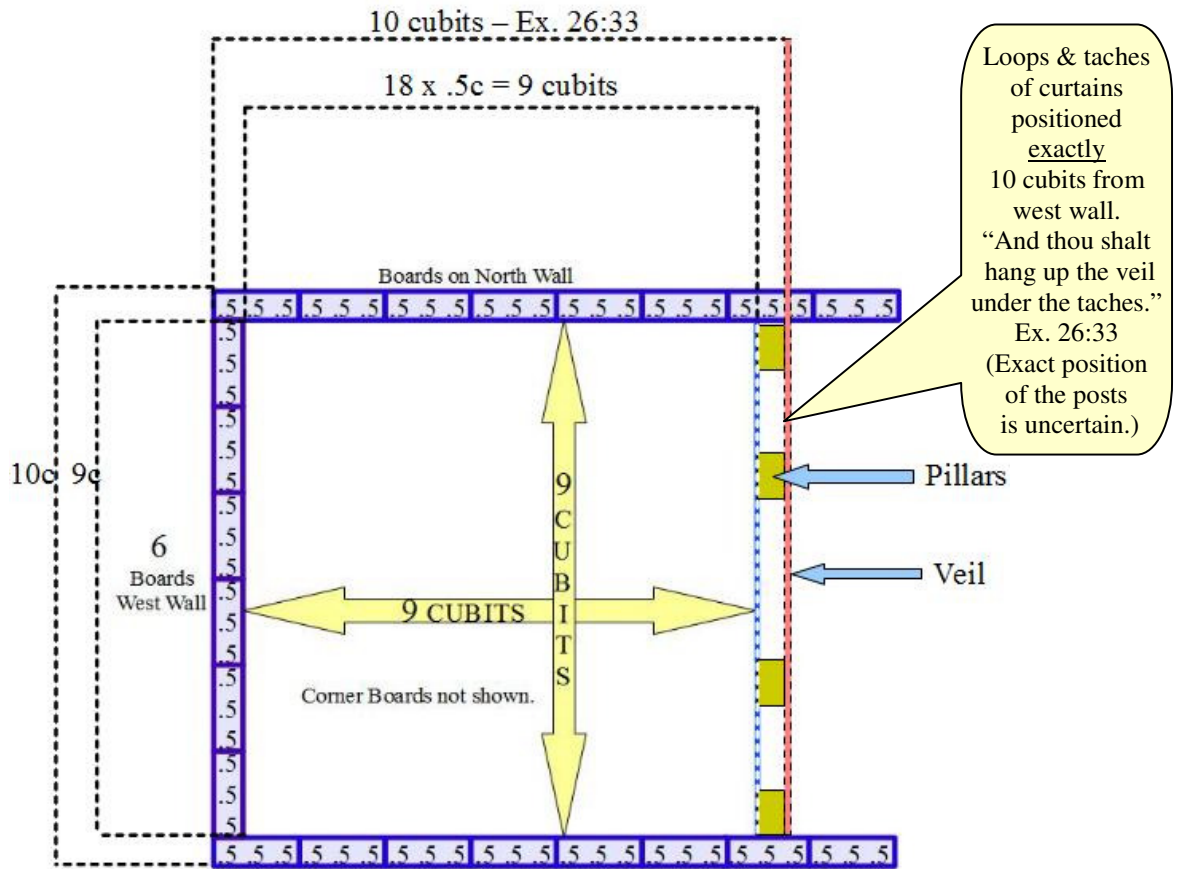

Note:

“As the inner veil of the sanctuary did not extend to the top of the building, the glory of God, which was manifested above the mercy seat, was partially visible from the first apartment.”
Patriarchs and Prophets, p. 353

THE 48 TABERNACLE BOARDS
 divided by the 81 square inches of the Breastplate of Judgment.
2520 & 360.

BREASTPLATE
 9" = one span
 9" = ½ cubit.

 9" x 9" = 81sq. in.

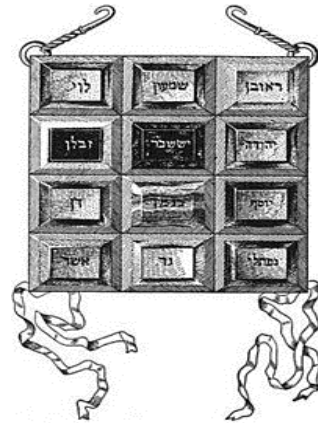

EACH BOARD HAS 15 SQUARE CUBITS

42 Boards x 15sc = 630sc
 630sc x 324si = 204,120si
204,120si divided by 81si
= 2520

6 Boards x 15sc = 90sc
 90sc x 324si = 29,160si
29,160si divided by 81si
= 360

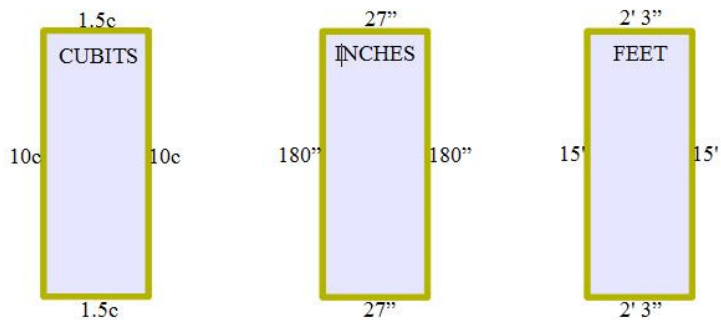

1 Thess. 5:4-8

But ye, brethren, are not in darkness, that that day should overtake you as a thief. Ye are all the children of light, and the children of the day: we are not of the night, nor of darkness. Therefore let us not sleep, as do others; but let us watch and be sober. For they that sleep sleep in the night; and they that be drunken are drunken in the night. But let us, who are of the day, be sober, putting on the *breastplate of faith and love*; and for an helmet, the hope of salvation.

10.5 SECTIONS OF THE GOAT'S HAIR COVERING

Divided by the 81 square inches
of the Breastplate of Judgment
= 5040 or 2 x 2520.

30c x 42c = 1260sc
 1260sc x 324* sq. in. = 408,240 square inches
 408,240 square inches divided by 81 square inches
= 5040 or 2 x 2520

*18" x 18" = 324 square inches.



BREASTPLATE
is 9" x 9" or 81 sq. in..

WEST EDGE = 30 CUBITS	
4c	4c
8c	8c
12c	12c
16c	16c
20c	20c
24c	24c
28c	28c
32c	32c
36c	36c
40c	40c
41c	41c
42c	42c
SOUTH EDGE 42 CUBITS	NORTH EDGE 42 CUBITS
EAST = 30 CUBITS	
43c	43c
This two cubits is doubled under first two cubits.	
44c	44c

2 x 81 PILLARS = 162

<p>John 10:23 And Jesus walked in the temple in Solomon's porch.</p>	<p>Acts 5:12 And by the hands of the apostles were many signs and wonders wrought among the people; and they were all with <u>one accord</u> in Solomon's porch.</p>
--	--

TWO ROWS OF COLUMNS WITH 81 PILLARS IN EACH ROW

Solomon's colonnade or portico on the east side of the Temple, in the outer courtyard.

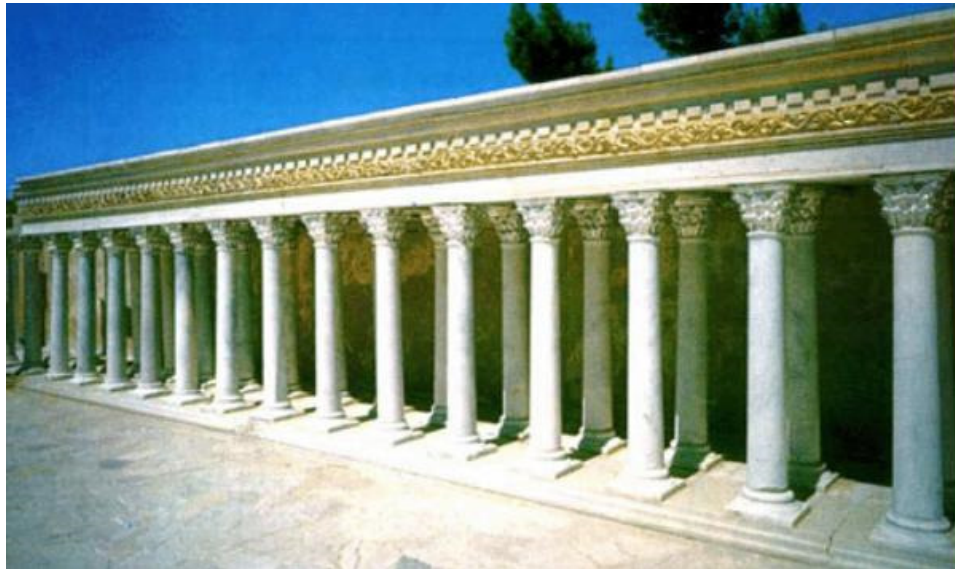

The porch along the eastern wall was known as Solomon's Porch. It was the only part of the temple built by Solomon that was still standing in the days of Jesus.

The columns (according to some sources, a double row of 81, equaling 162 in total) shown in the photo above, were found on the eastern side of the outer court of Herod's Temple. This entire area, which overlooked the Kidron Valley, was called Solomon's Colonnade.

Note:

The West Wall Boards of the Wilderness Tabernacle add up to 162".

Each Board was 1.5c in width x 6 Boards = 9c x 18" = 162".

The Breastplate of Judgment is from fabric folded over to become foursquare (9" x 9").

If it is unfolded it's square-inch measurement is 162".

CHAPTER 4

The Brazen Altar
The Golden Incense Altar
The Ark of the Covenant

THE ARK OF THE COVENANT, THE GOLDEN INCENSE ALTAR
AND THE BRAZEN ALTAR ADD UP TO **2520** LINEAR CUBITS

$$44c + 64c + 32c = 140c$$
$$140 \text{ cubits} \times 18'' \text{ cubit} = \mathbf{2520}$$

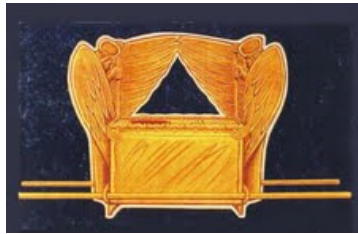

The Ark of the Covenant
has **44 linear cubits**.
(Shown here with the Day of Atonement
blood on the end "eastward". Lev. 16:14)
www.ArkDiscovery.com



The Brazen Altar has
64 linear cubits.



The Golden Incense Altar has
32 linear cubits.

$$17.5''$$
$$140c \times 17.5''$$
$$=$$
$$\mathbf{2450''}$$

THE BRAZEN ALTAR

Exodus 27:1

And thou shalt make an altar of shittim wood, five cubits long, and five cubits broad; the altar shall be foursquare: and the height thereof shall be three cubits.



http://www.templebuildersministry.com/Index_tabernacle.php

THE DESCRIPTION OF THE BRAZEN ALTAR:

1. The Altar was in a hollow box shape; it was foursquare, measuring 5x5x3 cu. high (7.5x7.5x4.5 feet)
2. The Altar was made of Shittim wood (or acacia wood) and then overlaid with brass (copper); it was the LARGEST and HIGHEST piece of furniture.
3. There were 4 horns on the 4 corners.
4. A grated network (grid) was inside the Altar 1.5 cubits from the Earth (half-way) ; there were rings and staves made of wood and brass.
5. There was a compass and ledge around the outside.
6. There were utensils - pans, shovels, basins, fleshhooks, and firepans.
7. The fire on the Altar was NEVER TO GO OUT; it was to burn continually.

THE BRAZEN ALTAR HAS 64 LINEAR CUBITS
 $64c \times 18'' = 1152'' / 144'' = 8 \times 144''$
 (Assembled the perimeter is $20c \times 18'' = 360''$).

EXODUS 27:1

And thou shalt make an altar of shittim wood, five cubits long, and five cubits broad;
 the altar shall be foursquare: and the height thereof shall be three cubits.

Leviticus 6:9-13

The fire shall ever be burning upon the altar; *it shall never go out.*

<p>2 Chronicles 7:9 And <u>in the eighth day</u> they made a solemn assembly: for they kept the <u>dedication of the altar</u> seven days, and the feast seven days.</p>	<p>Leviticus 9:7-24 And <u>there came a fire out from before the LORD</u>, and consumed upon the altar the burnt offering and the fat: which when all the people saw, they shouted, and fell on their faces.</p>
---	--

$4 \times 16c = 64c \times 18'' = 1152''$ divided by $144'' = 8$

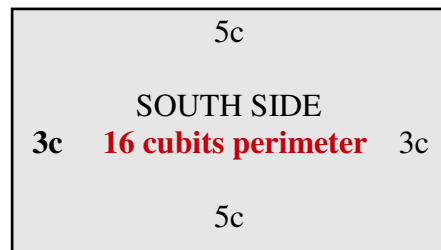
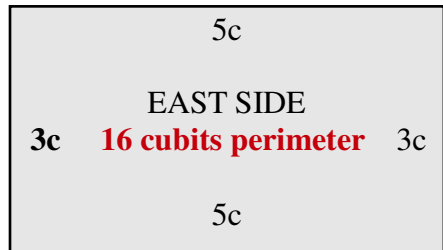
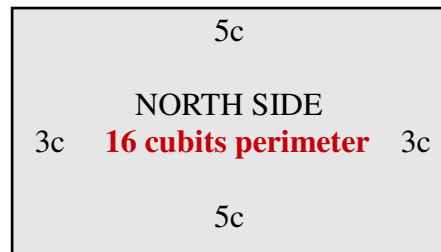
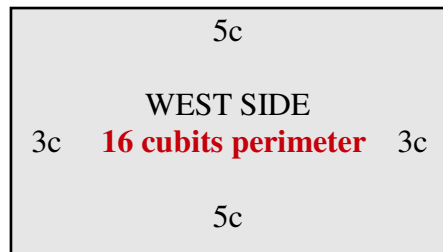

The grill at the top and pan at the bottom are not measured.

AT THE DEDICATION OF THE ALTAR,
GOLD AND SILVER VESSELS
VALUED AT **2520** SHEKELS WERE OFFERED
(2400 shekels + 120 shekels = **2520 shekels**)

<p style="text-align: center;">Numbers 7:1-2</p> <p style="text-align: center;"><i>And it came to pass on the day that Moses had fully set up the tabernacle, and had anointed it, and sanctified it, ... That the princes of Israel, heads of the house of their fathers, who were the princes of the tribes, and were over them that were numbered, offered verses 12-86: ...besides the animals, gold and silver vessels totaling 2520 shekels. This was the dedication of the altar, in the day when it was anointed, by the princes of Israel:</i></p>	<p>Cont: twelve chargers of silver, twelve silver bowls, twelve spoons of gold: Each charger of silver weighing an hundred and thirty shekels, each bowl seventy: all the silver vessels weighed two thousand and four hundred shekels, after the shekel of the sanctuary: The golden spoons were twelve, full of incense, weighing ten shekels apiece, after the shekel of the sanctuary: all the gold of the spoons was an hundred and twenty shekels.</p>
--	--

487 years later the Wilderness Tent and Ark of the Covenant were brought to Solomon's Temple at its Dedication.
(See *Seventh-day Adventist Bible Commentary*, Vol. 2, p. 762)

“At the appointed time the hosts of Israel, with richly clad representatives from many foreign nations, assembled in the temple courts. The scene was one of unusual splendor. Solomon, with the elders of Israel and the most influential men among the people, had returned from another part of the city, whence they had brought the ark of the testament. From the sanctuary on the heights of Gibeon had been transferred **the ancient "tabernacle of the congregation, and all the holy vessels that were in the tabernacle"** (2 Chronicles 5:5); and these cherished reminders of the earlier experiences of the children of Israel during their wanderings in the wilderness and their conquest of Canaan, **now found a permanent home in the splendid building** that had been erected to take the place of the portable structure. “ {PK 38.1 }

The Ark of the Covenant was brought into the Most Holy place. The Boards, Curtains, Courtyard Hangings, Pillars, etc. must have been stored in the WEST building. No one seems to know what this building was used for. It was 70 cubits by 90 cubits, certainly large enough to store it all. The location of this building being in line with the Temple and the East Gate is also indicative.

The Wilderness Tabernacle may have been stored in this west building.

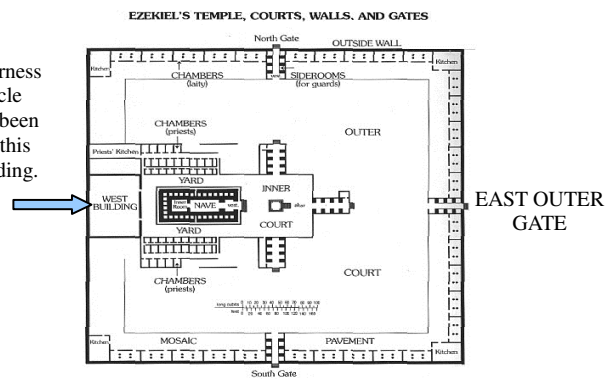

THE GOLDEN ALTAR OF INCENSE

32 LINEAR CUBITS = 4 x 144

Exodus 30:1-2

And thou shalt make an altar to burn incense upon: of shittim wood shalt thou make it. A cubit shall be the length thereof, and a cubit the breadth thereof; foursquare shall it be: and two cubits shall be the height thereof: the horns thereof shall be of the same.

Linear cubits around the *disassembled* Altar:

Top & bottom = 8c
4 long side Boards = 24c
Total = 32 linear cubits
32c x 18" = 576"/144 = 4 x 144



Square inches of the *disassembled* Altar:

Side Boards = 8sc x 324si = 2592"/144 = **18 x 144**
 Top & Bottom = 2sc x 324si = 648/144 = **4.5 x 144**

VOICE OF REV. 18:4-5

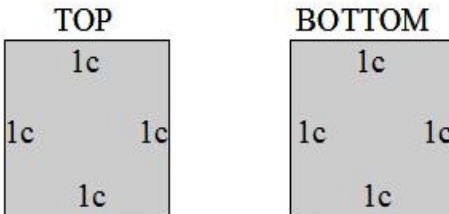

8c x 18" = 144"

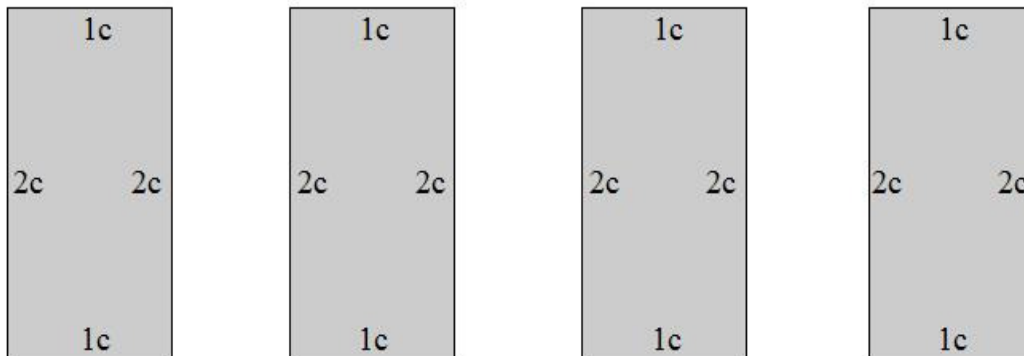

Each side Board is **6c x 18" = 108"**
4 Boards x 108" = 432"/144 = 3

ARK OF THE COVENANT = 44 LINEAR CUBITS



Linear cubits around
disassembled Ark:

MERCY SEAT = 8c
THREE LONG BOARDS = 24c
TWO ENDS = 12c
= 44 linear cubits

EXODUS 25:10-17

And they shall make an ark of shittim wood:
two cubits and a half shall be the length thereof, and a cubit and a
half the breadth thereof: and a cubit and a half the height thereof.
And thou shalt make a mercy seat of pure gold: two cubits and a half
shall be the length thereof, and a cubit and a half the breadth thereof.

THE TWO END BOARDS

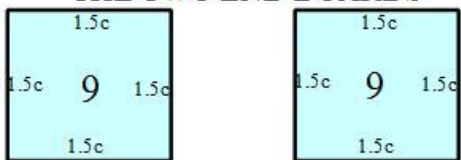

$$4 \times 1.5 = 6c$$

$$6c \times 18'' = 108''$$

$$2 \times 108'' = 216''/12'' = 18'$$

MERCY SEAT

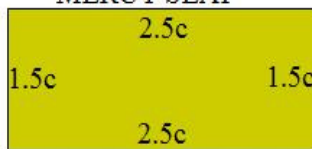

$$8c \times 18'' = 144''/12'' = 12'$$

SIDE BOARD

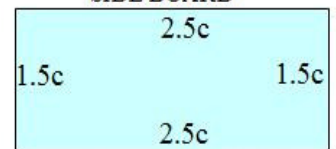

$$8c \times 18'' = 144''/12'' = 12'$$

BOTTOM BOARD

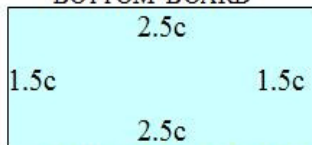

$$8c \times 18'' = 144''/12'' = 12'$$

SIDE BOARD

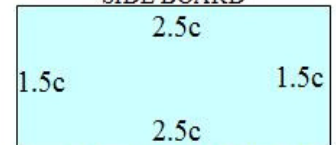

$$8c \times 18'' = 144''/12'' = 12'$$

THE ARK OF THE COVENANT IS THE 49th BOARD

48 Tabernacle Boards + the 4 smaller Ark Boards = 49 Boards @ 360 each (18" cubit) = 17,640

$$17,640'' \text{ divided by } 2520 = 7 \times 2520$$

The four long sides Ark of the Covenant when laid end to end have the same measure as one Board of the Tabernacle frame. Just as the 70th Pillar represented Jesus enshrouded in the pillar of cloud and fire, this 49th Board enshrouds the Ten Commandments set inside the Ark.

ONE BOARD = 360"
48 BOARDS OF TABERNACLE AND FOUR LONG SIDE BOARDS OF THE ARK = 49 BOARDS x 360 or 17,640

17.5"
One Board 20c x 17.5" = 350c
49 x 350c = 17,150"
divided by **2450 = 7**

49 Boards symbolize the "sabbaths-of-the-land" law of Leviticus 25:8-16 (see page 19)

49 years is 17,640 literal prophetic days. Out of those 17,640 days there were a total of 2520 literal days in which the land was to rest.

After 2450 years (49 x 50-year Jubilees), the trumpet of the Great Jubilee sounded on Oct. 22, 1844.

Noah's Ark with 700 linear cubits also has 17,640 linear inches using the 25.2" cubit for a total of 7 x 2520.

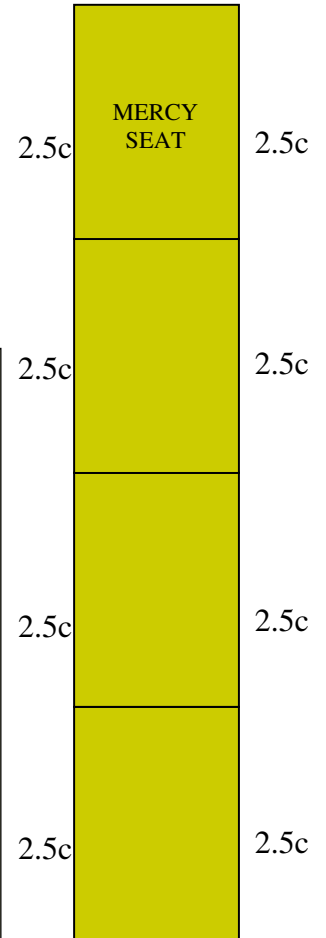

$$\begin{matrix} 10c & + & 10c \\ 180'' & + & 180'' \\ \hline 20c = 360'' \end{matrix}$$

$$\begin{matrix} 10c & + & 10c \\ 180'' & + & 180'' \\ \hline 20c = 360'' \end{matrix}$$



THE TWO ANGELS AT THE ENDS OF THE ARK

10c tall x 20c wingspan
(2Chron. 3:11-13; 1 Kings 6:23-27)

One Angel plus One Angel
at this end at that end

= TWO ANGELS

“The first and second angels' messages were given at the right time and accomplished the work which God designed to accomplish by them.” GC 405

“...as they waited and watched and prayed to know the will of God they saw that their great High Priest had entered upon another work of ministration, and, following Him by faith, they were led to see also the closing work of the church. They had a clearer understanding of the first and second angels' messages, and were prepared to receive and give to the world the solemn warning of the third angel of Revelation 14.” GC 431

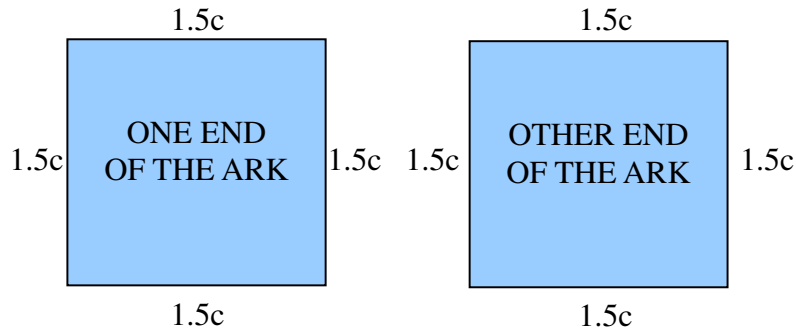

<p style="text-align: center;">Breastplate of the High Priest. Ex. 28:16</p>  <p style="text-align: center;">9” is half a cubit or a span. 9" x 9" = 81 square inches.</p>	<p style="text-align: center;">The square of each end is 9:</p> <p style="text-align: center;">1.5c x 1.5c = 2.25c 2.5c x 324si (the square of 18" x 18") = 729si.</p> <p style="text-align: center;">729si divided by the 81si of the Breastplate = 9</p> <p style="text-align: center;">TWO ENDS = 9 + 9 = 18 (Angel of Rev. 18)</p>
--	--

Solomon's Tower/Porch and Zechariah's Roll are also 10c x 20c
(1 Kings 6:3, 2 Chron. 3:4, Zech. 5:2)

THE THIRD AND FOURTH ANGELS

I saw that there was a cherub sitting on either end of the mercy seat
with their wings spread over the ark.

There also stood two angels, one by either end of the ark,
With their wings spread out on high and touching each other,
while their other wings reached to each side of the apartment.

I saw that the wings of the angels did not reach above the Father, for that
would bring Him too low.

I saw that the Father was in the midst above the cherubims,
and His glory is shed down upon the ark,
and the train of His glory fills the temple.

From the unpublished EGW Manuscripts released by SDAnonymous, vol. 1, p. 50-51.

Manuscript 15, 1850.

Written October 23, at Dorchester, Massachusetts.

This manuscript is an account of Ellen White's vision at Dorchester, Massachusetts.

Some parts are similar to Present Truth, November 1, 1850.

(Compare 1SOP 272)

On each end of the mercy-seat was fixed a cherub of pure, solid gold. Their faces were turned toward each other, and were looking reverentially downward toward the mercy-seat, which represents all the heavenly angels looking with interest and reverence to the law of God deposited in the ark in the heavenly sanctuary. These cherubs had wings. One wing of each angel was stretched forth on high, while the other wing of each angel covered their forms. The ark of the earthly sanctuary was the pattern of the true ark in Heaven. There, beside the heavenly ark, stand living angels, at either end of the ark, each with one wing overshadowing the mercy-seat, and stretching forth on high, while the other wings are folded over their forms in token of reverence and humility.

CHAPTER 5

SOLOMON'S AND EZEKIEL'S TEMPLES

“David gave Solomon minute directions for building the temple, with **patterns** [**blueprints**] ***of every part***, and of all its instruments of service, as had been revealed to him by divine inspiration.”

E.G. White, *Patriarchs and Prophets*, p.751

“Solomon's temple was the most magnificent building which the world ever saw.”

The Great Controversy, p. 23

Ezekiel 43:10

Thou son of man, show the house to the house of Israel,
that they may be ashamed of their iniquities:
and let them [you and I] measure the pattern.

Son of man, describe to the people of Israel the Temple I have shown
you. Tell them its appearance and its plan so they will be ashamed
of all their sins. And if they are ashamed of what they have done,
describe to them all the specifications of its construction —
including its entrances and doors — and everything else about it. Write down all
these specifications and directions as they watch so they will be sure to remember them.
(Eze. 43:10, NLT)

"The Lord showed me that he, James, must take the testimonies that the leading Adventists published in '44,
and republish them and make them ashamed (Ezekiel 43:10-11). He is now doing that work." --Letter 8, 1850

By 1863 the 2520 was found by some leaders
(including Uriah Smith and James White)
to be “wrong” and so was put aside.

Now it is unsealed again for our time to make us ashamed!

THE TEMPLES

INTRODUCTION

The account in Ezekiel of the Temple is not complete.

There are major and important parts that are completely left out of the description. When reading about Solomon's temple, as recorded in Kings and Chronicles a similar problem is presented. God has inspired His word to be written in a way that makes it necessary to search through the whole Bible on a subject before it can be correctly understood.

“All must agree, that God has in many places, and at divers times, revealed future things in figures, emblems, types and allegories; and, as I believe, for wise and benevolent purposes. The most prominent is, that in order to get anything clear, the Bible student must study the whole.”

Miller's Works, vol. 1, p.51-52.

This is known as the “proof-text” method of study. This is the same type of study that led William Miller and the other SDA pioneers to their knowledge of the prophetic periods.

This is the correct method of study, contrary to the anti-supernatural “historical critical method” or “historical method” which puts human reason above the word of God.

These Temple measurements were designed by a supernatural and infinite mind which no human reason could have invented.

Ezekiel 40:3-4

And he brought me thither, and, behold, there was a man, whose appearance was like the appearance of brass, with a line of flax in his hand, and *a measuring reed*; and he stood in the gate. And the man said unto me, Son of man, behold with thine eyes, and hear with thine ears, and set thine heart upon all that I shall show thee; for to the intent that I might show them unto thee art thou brought hither:
declare all that thou seest to the house of Israel.

SOLOMON'S AND EZEKIEL'S TEMPLES ARE MEASURED BY THE 21" CUBIT

(Most Biblical scholars give the 21" cubit for these two temples.)

2 Chron. 3:3 – “The length by cubits *after the first measure...*”

The “first measure” of 18 inches was for the Wilderness Tabernacle.

Adding a hand breadth (3") makes the “cubit and an hand breadth” to be 21 inches.

THE TEMPLE GATES

THE LORD LOVETH THE GATES OF ZION

MORE THAN ALL THE DWELLINGS OF JACOB Ps. 87:2

<p>Ps. 118:19-20 Open to me the gates of righteousness: I will go into them, and I will praise the LORD: This gate of the LORD, into which the righteous shall enter.</p>	<p>Rev. 22:14 Blessed are they that <i>do his commandments,</i> that they may have right to the tree of life, <i>and may enter in through the gates</i> into the city.</p>
<p>Ps. 24:7 Lift up your heads, O ye gates; and be ye lift up, <i>ye everlasting doors</i>; and the King of glory shall come in.</p>	<p>Ps. 122:1-3 I was glad when they said unto me, Let us go into the house of the LORD. Our feet <i>shall stand within thy gates</i>, O Jerusalem.</p>

Enter into his gates with thanksgiving,
and into his courts with praise: be thankful unto him,
and bless his name. For the LORD is good; his mercy
is everlasting; and **his truth** endureth to all generations Ps. 100:4-5

WHAT DO THE GATES IN SOLOMON'S AND EZEKIEL'S INNER AND OUTER COURTYARDS LOOK LIKE?

No artist can duplicate the beauty of the
entire Temple and its surrounding columns or buildings.

We think of a gate as is on the right.
This is not what the gates
looked like in Solomon's or Ezekiel's outer and inner
courtyards. Those gates were quite complex and
much more than mere doors through a wall. The
40th chapter of Ezekiel is the only place in the Bible
where these gates are described in detail.



The gates giving entry to Solomon's and Ezekiel's temples were large buildings with chambers.
There were three gates to the Outer Court, and three gates to the Inner Court.
These gates are not to be confused with the gates of Herod's temple or the gates into the city of Jerusalem.

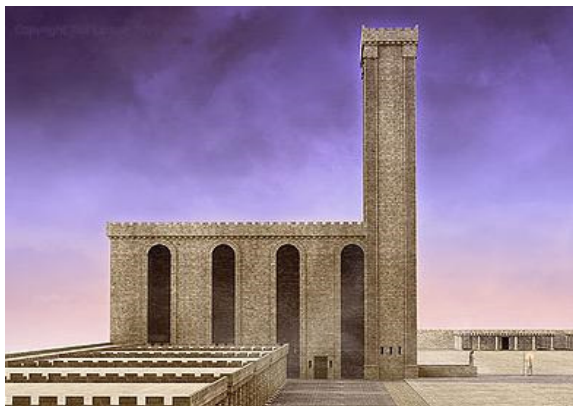

Side view of a modern version of Ezekiel's gate
with a 1260" tower facing the outer courtyard.

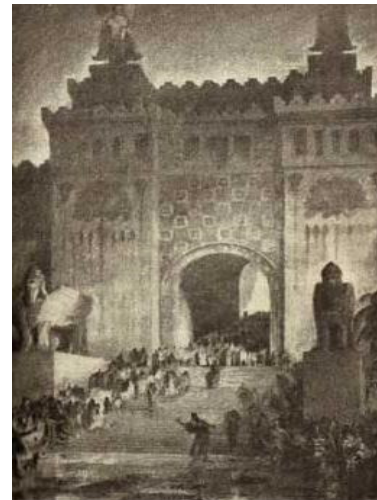

The front of Solomon's Gate by an
unknown artist. More likely a gate
into the city rather than the courtyard.

Opinions differ as to their actual architectural style, but the floorplan of the gates as given in Ezekiel has been proven from recent archaeological discoveries in Megiddo, Hazor, and Gezer. In these photos you can see the three chambers on each side of the passageway.

The symbolism behind the measurements of those six little chambers was hidden for our time.

1 Kings 9:15

And this is the reason of the levy which king Solomon raised; for to build the house of the LORD, and his own house, and Millo, and the wall of Jerusalem, and Hazor, and Megiddo, and Gezer.

“It has been recognized for a long time that in its essential features Ezekiel's temple was patterned like Solomon's Temple, and recently discovered archaeological evidence indicates that *Ezekiel's gates, described in great detail, almost exactly matched gates built by Solomon's architects at Megiddo, Hazor, and Gezer.* These discoveries show that the description of either Solomon's Temple or of Ezekiel ideal structure can be used to clarify *structural and architectural details of the other.*”

Seventh-day Adventist Bible Commentary, Vol. 8, p. 1099:

Ariel view of Hazor.

The arrows point to what were two towers.



Woman stands next to the remains of a tower.

Hazor became the northern stronghold for King Solomon. In the Upper City, archaeologists have uncovered storehouses, stables, and a six-chambered gate, which is the same size and design as the gates at Megiddo and Gezer. The structural similarity of these structures and gates establish that they were all built by King Solomon's empire, matching the record of the Old Testament.

It seems the only difference between these gates and the gates into the outer and inner courtyard of the temple is that these towers were connected to the wall of the city, while the towers of the gate which covered the porch area were inside the outer gate and outside the inner gate. The courtyard towers faced each other.

To the right, Henry Sulley's* fanciful drawing of what a gate might have looked like. It is more beautiful than most drawings, but does not quite match the correct floor plan of Gezer, Megiddo and Hazor's gates. The height and dimension are closer to reality. This better fits the description E.G. White gives of Solomon's Temple being the "most magnificent building which the world ever saw."

GC 23.

* Lived 1845-1940. English architect and writer on the temples of Jerusalem. He was a Christadelphian.

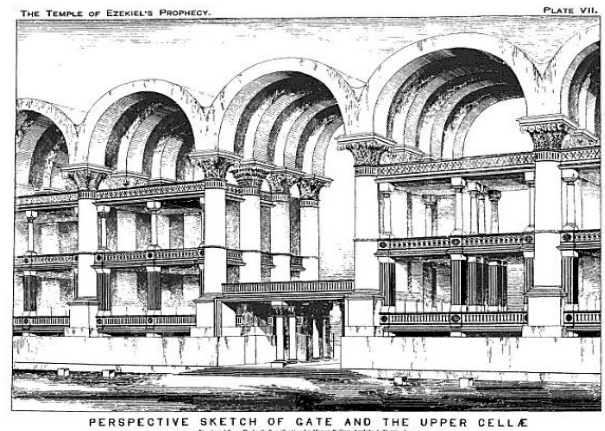

“THESE GATES”

Jeremiah 17:19-20 Thus said the LORD unto me; *Go and stand in the gate* of the children of the people, whereby the kings of Judah come in, and by the which they go out, and in **all the gates of Jerusalem**; And say unto them, Hear ye the word of the LORD, ye kings of Judah, and all Judah, and all the inhabitants of Jerusalem, *that enter in by these gates*:

JEWISH ENCYCLOPEDIA.COM By: Emil G. Hirsch, Ph.D., LL.D.,
Professor of Rabbinical Literature and Philosophy,
University of Chicago; Chicago, Ill.

“As the gate protected the whole city, the word came to be used for the city itself (Isa. xiv. 31; Ex. xx. 10; Deut. xvi. 5; Ruth iii. 11). The king's court is also designated as the "gate" (Esth. iii. 2; Dan. ii. 49; comp. Esth. ii. 19 *et seq.*). The gate and the adjoining open area constituted the market-place (Neh. viii. 16, xiii. 19; Job xxix. 7; II Kings vii. 1); hence such names as "fish-gate," "sheep-gate" (Neh. iii. 1, 3, 32; xii. 39; Zeph. i. 10). The gates offered the main opportunity for social intercourse. The wells were sometimes situated here (II Sam. xxiii. 15-16). Here news from the outside was sure to be announced first (I Sam. iv. 18); private grief or public calamity found "at the gate" ready sympathizers among the assembled throng of idlers (comp. II Macc. iii. 19; Gen. xix. 1; Ps. lxxix. 12 [A. V. 13]; Prov. xxxi. 31); matters of public concern were discussed (I Kings xxii. 10; Jer. xxxviii. 7; at the gates of the Temple, Ezek. xi. 1; Jer. xxvi. 10 *et seq.*), **public announcements were made** (Jer. xvii. 19 *et seq.*; Prov. i. 21, viii. 3), **and court and council sessions were held here** (Job xxix. 7, xxxi. 21; Prov. xxxi. 23; Lam. v. 14; Deut. xvi. 18, xxi. 19 *et seq.*, xxii. 15-16; Josh. xx. 4).”

“The Levite, the stranger, the widow that is "within thy gates" (Deut. xvi, 14, *et al.*) have a legal status and claim to kindly consideration (comp. Amos v. 12, 15). The heads of slain enemies were probably exhibited in the gates (I Sam. xvii. 51, 54; comp. II Kings x. 8). Criminals were punished outside the gates (I Kings xxi. 13), but near by, while lepers were sent out from the gates (Lev. xiii. 46; II Kings vii. 3), being assigned a settlement beyond the city limits but not too far from the city wall.”

“**Gates and doors were marked with inscriptions**
(Deut. vi. 9, xi. 20; [see Door](#); [Mezuzah](#)).

Camps also had gates (Ex. xxxii. 26-27).”

http://www.templeinstitute.org/future_temple.htm

“Thus, it should be noted when the Second Temple was erected, its builders incorporated a number of components that were based on Ezekiel's prophecy.

...“**All of those details from Ezekiel's prophecy that were not explained in the Second Temple era, remain sealed until that time when "the earth shall be filled with the knowledge of God, as the waters that cover the sea" (Isaiah 11:9).**

Boaz, the great-great grandfather of Solomon sat at a gate to make a deal for Ruth:

Boaz went to the town gate and took a seat there. Just then the family redeemer he had mentioned came by, so Boaz called out to him, “Come over here and sit down, friend, I want to talk to you.” So they sat down together. Then Boaz called ten leaders from the town and asked them to sit as witnesses. Ruth 4:1-2

Ezekiel 40:6-14

40:6 Then came he *unto the gate which looketh toward the east*, and went up the stairs thereof, and measured the threshold of the gate, which was one reed broad; and the other threshold of the gate, which was one reed broad.

40:7 And every little chamber was one reed long, and one reed broad; and between the little chambers were five cubits; and the threshold of the gate by the porch of the gate within was one reed.

40:8 He measured also the porch of the gate within, one reed.

40:9 Then measured he the porch of the gate, eight cubits; and the posts thereof, two cubits; and the porch of the gate was inward.

40:10 And the little chambers of the gate eastward were *three on this side, and three on that side*; they three were of one measure: and the posts had one measure on this side and on that side.

40:11 And he measured the breadth of the entry of the gate, ten cubits; and the length of the gate, thirteen cubits.

40:12 The space also before the little chambers was one cubit on this side, and the space was one cubit on that side: and the little chambers were six cubits [one reed] on this side, and six cubits [one reed] on that side.

40:13 He measured then the gate from the roof of one little chamber to the roof of another: the breadth was five and twenty cubits, door against door.

40:14 He made **{He made?}** also posts of threescore cubits, even unto the post of the court round about the gate.

40:15 And from the face of the gate of the entrance unto the face of the porch of the inner gate were fifty cubits.

The perimeter of the twelve Gates of Solomon's and Ezekiel's Temples
 = 15 x 2520

<p>Isaiah 62:10 Go through, go through the gates; prepare ye the way of the people; cast up, cast up the highway; gather out the stones; lift up a standard for the people.</p>	<p>Prov. 8:34-35 Blessed is the man that heareth me, watching daily at my gates, waiting at the posts of my doors. For whoso findeth me findeth life, and shall obtain favour of the LORD.</p>
--	---

Each gate has a perimeter measure of 150 cubits.
 Solomon's Temple has 6 gates, and Ezekiel's Temple has 6 gates.

There are **7 steps** leading up to each outer gate,
 and there are **8 steps** leading up to each inner gate: **7 + 8 = 15***.

Perimeter of each gate is:
 50c + 25c + 50c + 25c
 = 150c x 12 gates = 1800c

1800c x 21" = 37,800"
 divided by 2520 = 15

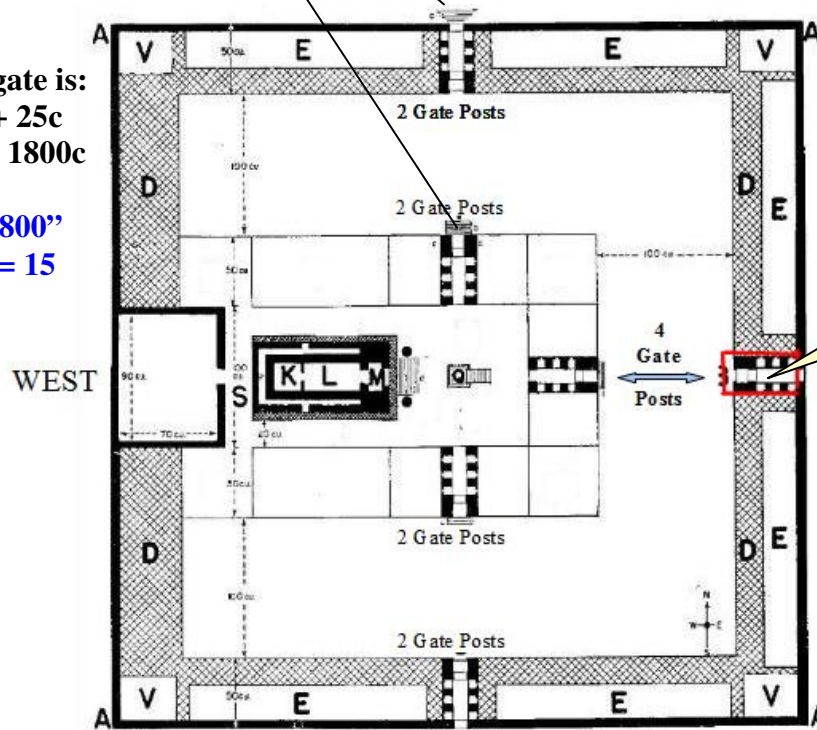

This is the East Gate with six its chambers. There are three gates to the Outer Court and three gates to the Inner Court. The Inner & Outer gate posts face each other.

Temple drawing is from 8BC, p. 1098

*Leviticus 23:6 And on the fifteenth day of the same month [first month] is the feast of unleavened bread unto the LORD:
 Numbers 9:12 And on the fifteenth day of the seventh month ye shall have an holy convocation;

THE VESTIBULE OF EACH GATE = 2450

x 6 Gates = 6 x 2450 (one Temple)
 or 12 x 2450 square feet (two Temples)
 (or 24 x 176,400 square inches)

There's that
 176,400
 again!

The Vestibule or Porch of Solomon's six Gate Towers (the floor & ceiling are both counted) has the same 2450 square feet as Solomon's Holy Place (6 x 2450), Most Holy (3 x 2450), and Brazen Altar (1 x 2450 square feet).

When entering the Outer Gate from outside the Temple area, a person walks up 7 steps (symbolizing perfection) and passes between the 6 LITTLE CHAMBERS which equal 144 cubits, then walks across the FLOOR and under the CEILING of the Vestibule which equals 2450, then enters the outer court by walking between the TWO GATE POSTS which equal 2520. Etering the Inner Court is just the opposite (a chiastic building structure, but instead of 7 steps up, there are 8 steps up, symbolizing resurrection or restoration of perfection). Continuing toward the Sanctuary, the Vestibule of the Inner Gate faces the vestibule of the Outer Gate and a person first walks between TWO POSTS which equal 2520, then walks across the FLOOR, and under the CEILING of the 2450 Vestibule, and then walks past the 6 LITTLE CHAMBERS that represent the number 144, and into the Inner court.

Outer East Gate

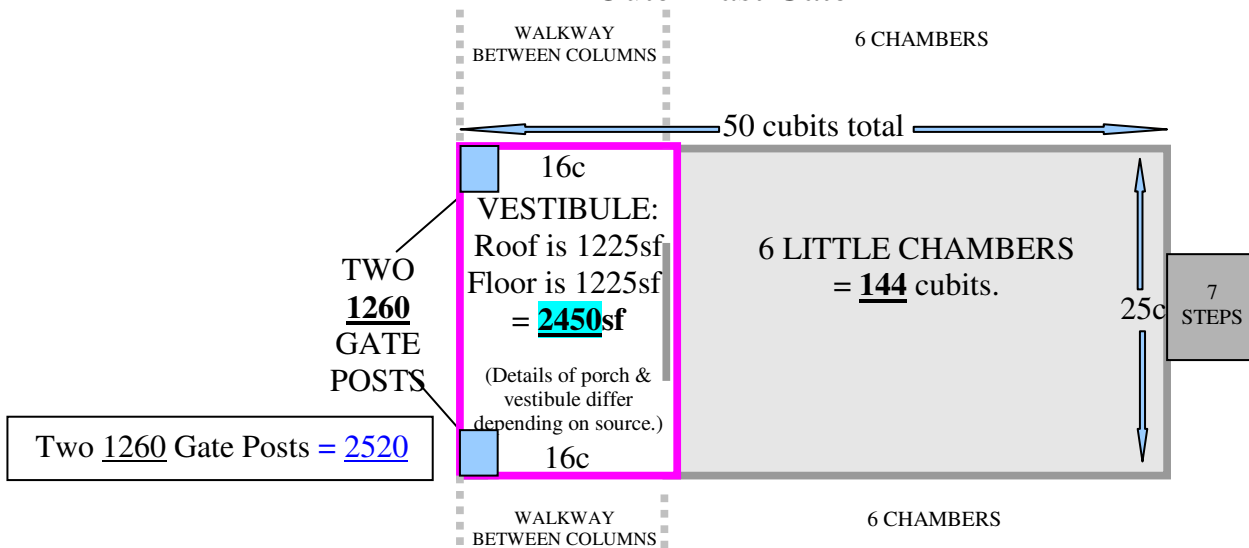

THE FLOOR & CEILING MEASUREMENT OF THE VESTIBULE:

<p>The vestibule's square cubits: 16c x 25c = 400 square cubits. 400sc x 441si (21" x 21") = 176,400 square inches. Divide 176,400si by 144si = 1225 square feet.</p> <p>Floor of Vestibule is 1225sf + Roof is 1225sf = 2450sf</p> <p>This square measure is the same as the floor space of Solomon's Altar and the Most Holy Place, and the same linear measure as Noah's Ark.</p>	<table border="1"> <tr> <th data-bbox="868 1612 1052 1642">FLOOR</th> <th data-bbox="1128 1612 1312 1642">CEILING</th> </tr> <tr> <td data-bbox="868 1675 1052 1831"> 16c x 25c = 400sc x 441si = 176,400si divided by 144si = 1225sf </td> <td data-bbox="1128 1675 1312 1831"> 16c x 25c = 400sc x 441si = 176,400si divided by 144si = 1225sf </td> </tr> <tr> <td colspan="2" data-bbox="950 1873 1328 1902"> Total is 1225sf + 1225sf = 2450sf </td> </tr> </table>	FLOOR	CEILING	16c x 25c = 400sc x 441si = 176,400si divided by 144si = 1225sf	16c x 25c = 400sc x 441si = 176,400si divided by 144si = 1225sf	Total is 1225sf + 1225sf = 2450sf	
FLOOR	CEILING						
16c x 25c = 400sc x 441si = 176,400si divided by 144si = 1225sf	16c x 25c = 400sc x 441si = 176,400si divided by 144si = 1225sf						
Total is 1225sf + 1225sf = 2450sf							

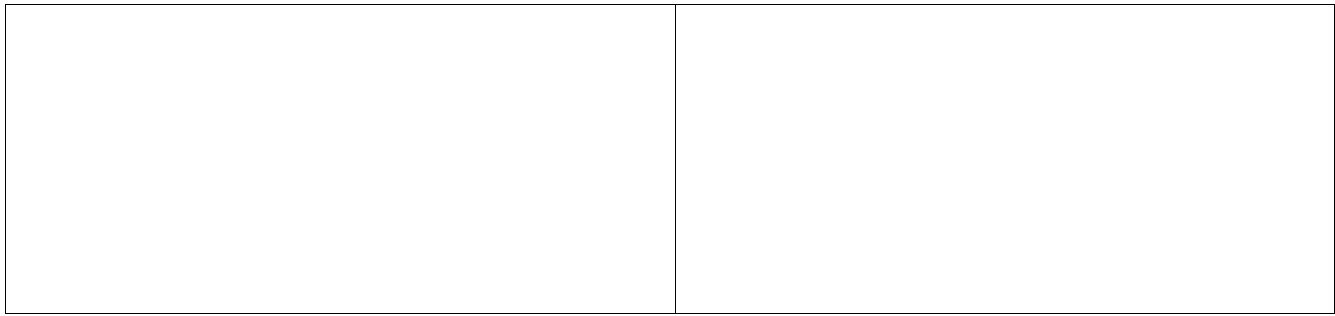

THE GATE POSTS

= 12 x 2520

Either the gate has one porch or vestibule with a tower 60 cubits (1260") in height, as some pictures show, or the gate itself is 60 cubits. Both views have two posts 60 cubits in height.

No matter how many Gates are measured there will be sums of 1260 and 2520.

<p>THE NEW KING JAMES READS: Ezekiel 40:9-14</p> <p>v. 9 ...and the gate posts thereof two cubits. v. 14: He measured the [two] gate posts, sixty cubits high, and the court all around extended to the gateposts.</p>	<p>These two posts and towers were on the inside of the outer gate, and on the outside of the inner gate. In other-words: they faced each other. There were dozens of columns around the court but these posts on each side of the entry and exits were specifically emphasized.</p>
--	--

GATE POST

60c = 1260"

Deut. 6:9

And thou shalt write them upon the posts of thy house, and upon thy gates:

Deut. 6:4-9
And thou shalt love the Lord thy God with all your heart, and with all your soul, and with all your might.

60c x 21" = 1260"
Two posts = 2520
Six Gates = 6 x 2520
Twelve Gates = 12 x 2520

21.6" cubit -
ONE GATE:
 60c x 21.6"
 = 1296" x 2 posts
 = 2592" /144
 = 18 x 144

17.5" cubit .
12 GATES
 60c x 17.5"
 = 1050" x 2 posts
 = 2100" x 12 gates
 = 25,200/2520
 = 10 x 2520

100

25.2" cubit -
Ezekiel's Temple
 60c x 25.2"
 = 1512" x 2 posts
 = 3024" x 6 gates
 = 18,144

GATE POST

60c = 1260"

Deut. 11:20

And thou shalt write them upon the door posts of thine house, and upon thy gates:

Deut. 11:13-21
Love the Lord your God and serve him with all your heart, and with all your soul.

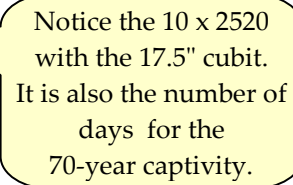

Notice the 10 x 2520
with the 17.5" cubit.
It is also the number of
days for the
70-year captivity.

CHAPTER 6

THE MOLTEN SEA & LAVERS

Rev 22:17

And the Spirit and the bride say, Come.

And let him that heareth say, Come.

And let him that is athirst come.

And whosoever will,

let him take the water of life freely.

THE MOLTEN SEA OF SOLOMON'S TEMPLE

1 Kings 7:23

And he made a molten sea, ten cubits from the one brim to the other: it was round all about, and his height was five cubits: and a line of thirty cubits did compass it round about.

Note: The Brazen Sea is 10 x 30 x 5.

In math class we learned that the circumference of a circle is "pi" or 3.14, so the 30 cubits around the Sea is God's generalization.

1 Kings 7:25

It stood upon twelve oxen, three looking toward the north, and three looking toward the west, and three looking toward the south, and three looking toward the east: and the sea was set above upon them, and all their hinder parts were inward.

There is such a wide variety of scholastic opinions on the measurements of this Brazen Sea that it is best to not attempt defining it's measurements except to note that the diameter is 210" and the circumference around the top is 630". If we combine those two measures the total is 840", a sum found often throughout the measuring of the temples (840 x 3 = **2520**).

Deut. 25:4
Thou shalt not muzzle the ox when he treadeth the corn.

1 Cor. 9:9;
For it is written in the law of Moses, thou shalt not muzzle the mouth of the ox that treadeth out the corn [grain, during the harvest].

1 Tim. 5:18
For the scripture saith: thou shalt not muzzle the mouth of the ox.

“Some commentators think Paul does not here refer to financial support, but to honor befitting position and creditable service ... this verse suggests that there is a deeper meaning then just kindness to animals.”
7BC, p. 313

Warning!

Don't muzzle (dishonor) God's Word
by not supporting its ministers (oxen)
during the time of the harvest!

The priests washed in the Molten Sea. The lavers were for washing the sacrifices.



"These twelve oxen were types of the twelve apostles of the Lamb, who, as these beasts, stood looking into the four corners of the earth, and were bid to go preach the gospel in all the world. They were compared to oxen, for the ox is a clean beast. ...They were compared to oxen because the ox is strong, and they also were mighty in the word, Prov.14:4; 2 Cor. 12:12.

The ox will not lose what he has got by drawing; he will not let the wheels go back, so the apostles were set to defend and not let that doctrine go back, for which they had preached to others; nor did they, they delivered it pure to us."

John Bunyan, *Solomon's Temple Spiritualized: or, Gospel Light Fetched out of the Temple*, 1786, p. 64.

THE BULLOCK REPRESENTS CHRIST
Ex.29:36 – And thou shalt offer every day a bullock for a sin offering...

THE TEN LAVERS OF SOLOMON'S TEMPLE

The Sea to wash the worshipers, but the Lavers to wash the Sacrifice.

*The priests washed from the water drawn from the Molten Sea.
The Sacrifice was washed from the water drawn from the Lavers.*

<p>1 John 5:6 This is he that came by water and blood, even Jesus Christ; not by water only, but by <u>water and blood</u>. And it is the Spirit that beareth witness, because the Spirit is truth.</p>	<p>"The inwards and legs of the burnt-offering was to be washed in these lavers, Lev. 1:9,13; 2 Chron. 4:6; to show that Christ should be pure and clean in heart and life." John Bunyan, <i>Solomon's Temple Spiritualized: or, Gospel Light Fetched out of the Temple</i>, 1786, p. 66,67.</p>
<p>1 Kings 7:39 And he put five bases on the right side of the house, and five on the left side of the house: and he set the sea the right side of the house eastward over against the south.</p>	<p>2 Chron. 4:6 He made also ten lavers, and put five on the right hand, and five on the left, to wash in them: such things as they offered for the burnt offering they washed in them; <u>but the sea was for the priests</u> to wash in.</p>



This picture gives a good perspective as to the correct height of the 10 Carts/Lavers. They were 4 cubits or 7 feet tall!

As you can see from the view of the Sea from the previous page, there are many differing views of how the Sea and Lavers were constructed.

10 CARTS WITH 40 WHEELS AND 10 LAVERS = 8 x 2520

1 Kings 7:27-40

And he made ten bases of brass; four cubits was the length of one base, and four cubits the breadth thereof, and three cubits the height of it. ...

Then made he ten lavers of brass: one laver contained forty baths: and every laver was four cubits: and upon every one of the ten bases one laver.

One of Ten Water Lavers



Two different pictures of the cart and laver.

There is a wide variation of opinion on the construction details of the carts and lavers.

We will keep it simple and measure **just as the Bible reads** using the 21" cubit. Remember: everything was measured before it was molded or assembled.



THE WHEELS = 2 x 2520

Diameter of one wheel = 1.5c
10 carts with 40 wheels = 40 x 1.5c = 60c

In 1 Kings 7:23, God has given us the rule for finding His circumference = 3 x diameter.

Cir. of one wheel = 3 x diameter of 1.5c = 4.5c
Cir. of 40 wheels is 40 x 4.5c = 180c

60c + 180c = 240c

240c x 21" = 5040"

5040 divided by 2520 = 2 x 2520

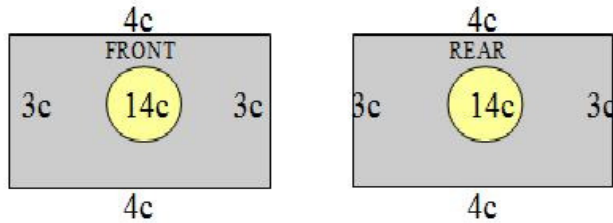

THE BASE & LAVERS = 6 x 2520

The Base:

4 sides x 14c = 56c x 10 carts = 560c

The Lavers:

Diameter = 4c x 10 carts = 40c

In 1 Kings 7:23, God has given us the rule for finding His circumference = 3 x diameter.

Cir. of one Laver = 3 x diameter of 4c = 12c
12c cir. x 10 Lavers = 120c

560c + 40c + 120c = 720c

720c x 21" = 15,120

15,120 divided by 2520 = 6 x 2520

15,120 is also the number for the 42 weeks of tilling, sowing and reaping of the "sabbaths-of-the-land."

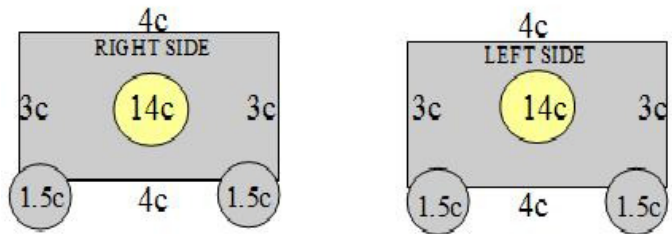

This drawing of the Inner Court is to scale showing the correct proportion of the Gates, Lavers, Altar & Sea. Does not show the depth of the walls.

Note: The Brazen Sea may be placed further to the west.

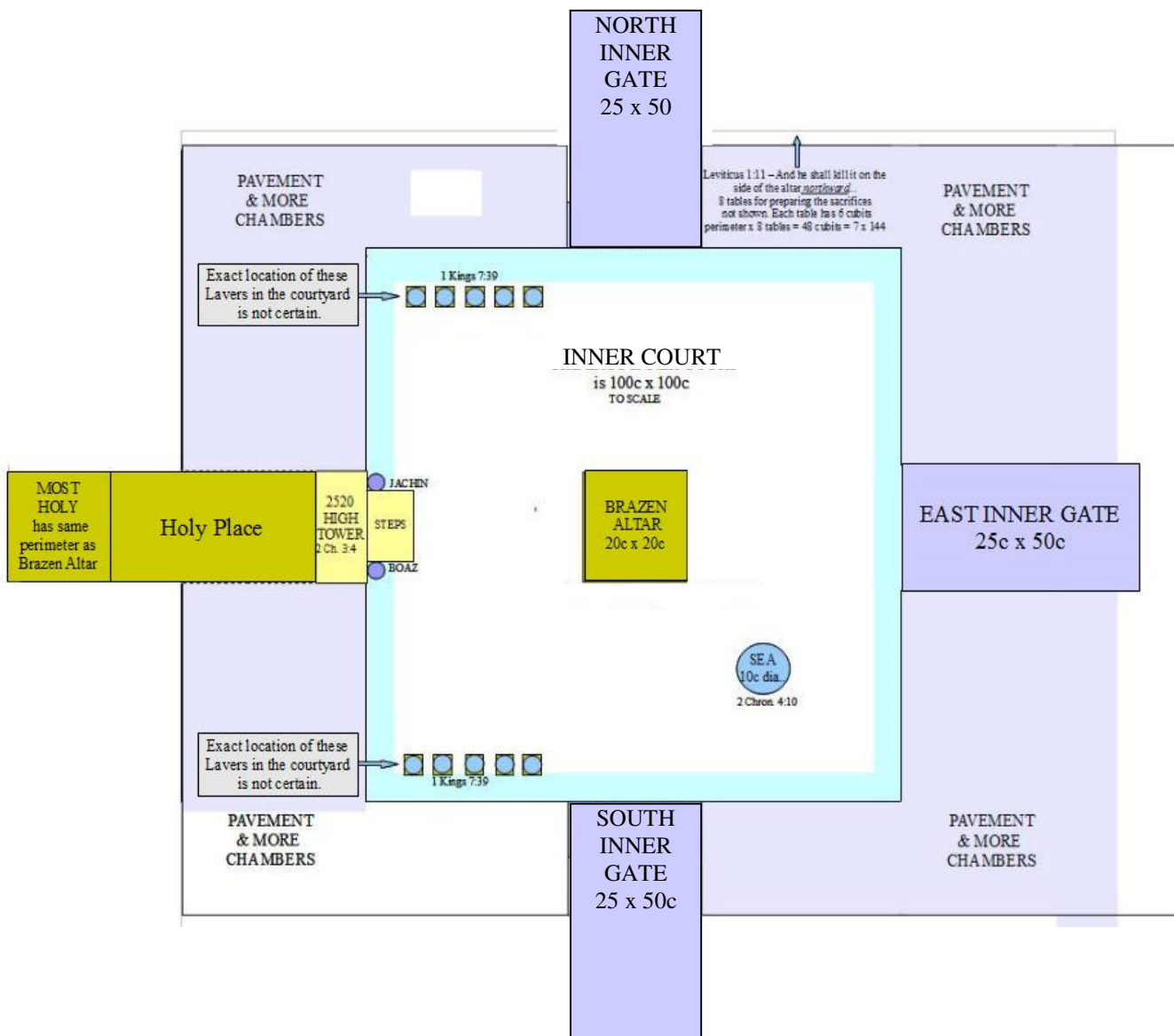

NO LAVERS & BRAZEN SEA IN EZEKIEL'S TEMPLE

In the Temple of Ezekiel neither Laver nor Brazen Sea are mentioned; instead, the waters issue out eastward from under the threshold of the house deepening and widening as it flows.
Ezekiel 47

Rev 22:1-3

And he shewed me a pure river of water of life, clear as crystal, proceeding out of the throne of God and of the Lamb. In the midst of the street of it, and on either side of the river, was there the tree of life, which bare twelve manner of fruits, and yielded her fruit every month: and the leaves of the tree were for the healing of the nations. And there shall be no more curse: but the throne of God and of the Lamb shall be in it; and his servants shall serve him:



CHAPTER 7

THE TWO ALTARS

"The Brazen Altar represents the putting
away and destruction of sin, ..."

Stephen Haskell , *The Cross and it's Shadow*, p. 62

MEASURING THE ALTARS OF SOLOMON'S AND EZEKIEL'S TEMPLES



Solomon's Altar



Ezekiel's Altar

SOLOMON'S BRAZEN ALTAR

2 x 2520 LINEAR INCHES

1 x 2450 SQUARE FEET*

723 B.C. - 1798 , PLUS 677 B.C. - 1844 = 2 x 2520

607 B.C. - OCT. 22, 1844 is the 2450 years of the 49 Jubilees.

2 Chron 4:1-2

Moreover he made an altar of brass, *twenty cubits* the length thereof, and *twenty cubits* the breadth thereof, and *ten cubits* the height thereof.

240c x 21-inch cubit = 5040"/2520" = **2 x 2520 linear inches.**

800sc x 441si = 352,800si/144si = **2450 square feet.**

(441 is the square inches of 21" x 21")

This does not quite match the description in Chronicles,



but they did have some kind of ledge to walk around the horns.

NORTH

SOUTH

EAST

WEST

10c x 20c =
200 sq. cubits or
60 linear cubits

10c x 20c =
200 sq. cubits or
60 linear cubits

10c x 20c =
200 sq. cubits or
60 linear cubits

10c x 20c =
200 sq. cubits or
60 linear cubits

60c + 60c + 60c + 60c = 240 linear cubits x 21-inch cubit = 5040 inches = **2 x 2520**

200sc + 200sc + 200sc + 200sc = 800 square cubits x 441 square inches = 352,800sc

Divide 352,800sc by 144si = **2450sf**

*The top and bottom of the Altar were not measured, neither was the top and bottom of the Wilderness Altar.

If the top and bottom of Solomon's Altar was measured there would be a second 2450.

20c x 20c x 2 = 800sc x 441si = 352,800si/144si = 2450sf.

These two Altars were literal Altars whereas Ezekiel's Altar has a spiritual application only.

EZEKIEL'S ALTAR

8 x 2520 LINEAR CUBITS
1 x 2520 SQUARE CUBITS

Ezekiel 43:13-17

And these are the measures of the altar after the cubits: The cubit is a cubit and an hand breadth; even the bottom shall be a cubit, and the breadth a cubit, and the border thereof by the edge thereof round about shall be a span: and this shall be the higher place of the altar. And from the bottom upon the ground even to the lower settle shall be two cubits, and the breadth one cubit; and from the lesser settle even to the greater settle shall be four cubits, and the breadth one cubit. So the altar shall be four cubits; and from the altar and upward shall be four horns. And the altar shall be twelve cubits long, twelve broad, square in the four squares thereof. And the settle shall be fourteen cubits long and fourteen broad in the four squares thereof; and the border about it shall be half a cubit; and the bottom thereof shall be a cubit about; and his stairs shall look toward the east.

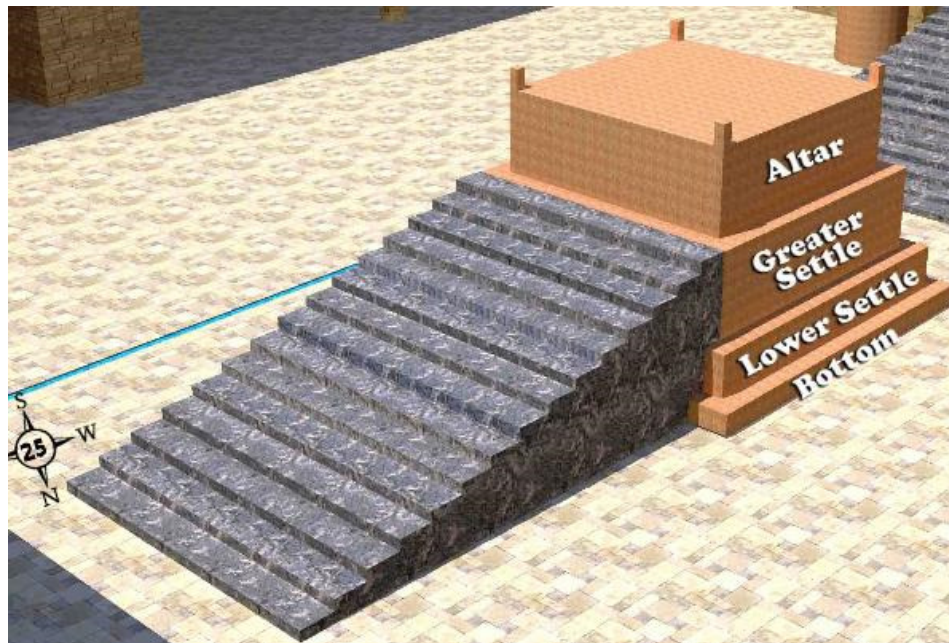

Ultra modern drawing of Ezekiel's Altar

(<http://bible.ag/en/enEzekielTranscript.htm>)

EZEKIEL'S ALTAR

“In Ezekiel's ideal Temple the Altar of burnt offering was to be built as follows: a base eighteen cubits square and a cubit high to be surmounted by a platform sixteen cubits square and two high; on this another platform fourteen cubits square and four high arose. Above this was the Altar hearth, twelve cubits square and four high. This at each corner was surmounted by a horn a cubit in height
 (see Toy's 'Ezekiel,' S. B. O. T. p. 191). ...”
<http://www.jewishencyclopedia.com/articles/1320-altar>

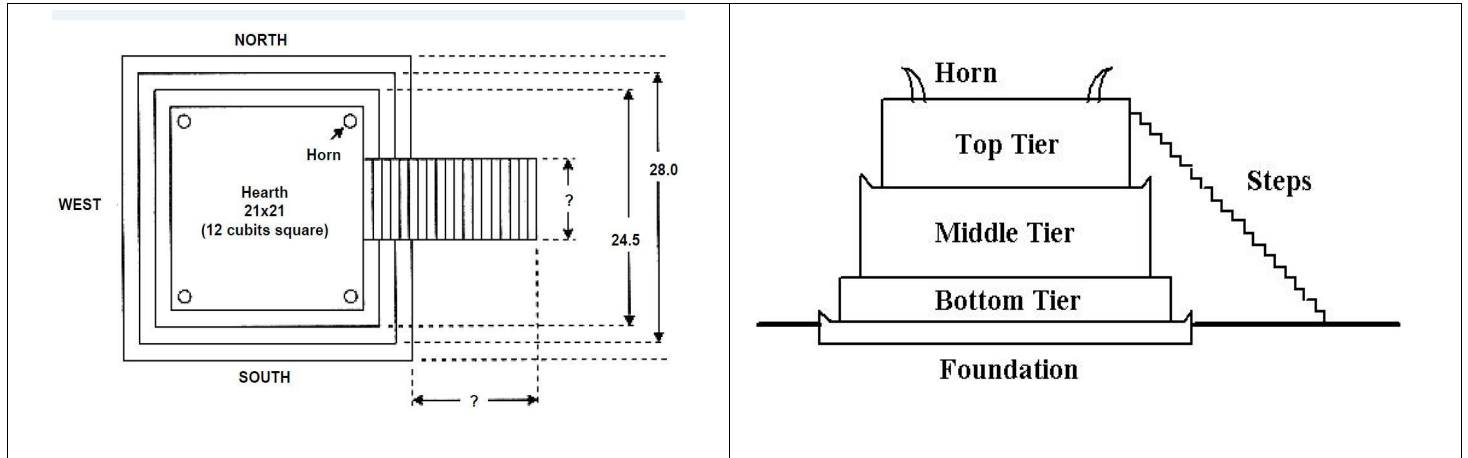

Old Testament studies which have been devoted to the form of the Altar disagree considerably about architectural details, but display a remarkable conformity on the shape of the altar as a whole. When compared, the different designs show a similar tower like structure composed of three platforms of diminishing size with a total height varying between ten and twelve cubits. Differences depend on different calculations, measuring the altar from the level of the ground up or from the bottom of the gutter which supposedly surrounded the altar.

The Altars as drawn by artists are quite variable. The 4 cubit height of the hearth is 7 feet (using the 21” cubit). A priest would have to be a giant in order to set an offering on top of the grill or sprinkle blood on the horns. There must have been a ledge for them to walk around the altar, or perhaps the third platform sat inside the second, and the second sat inside the first. The drawing below might be somewhat more accurate in that case.

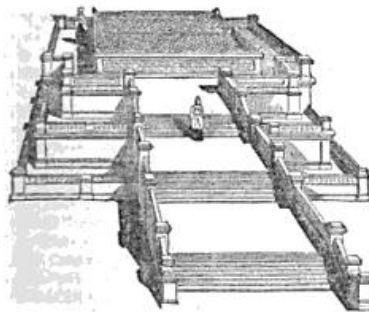

17,640 & 176,400

The perimeter of Solomon's Brazen Altar is the exact perimeter (20c x 20c) as the Most Holy. Each has 176,400 square inches. Noah's Ark has a perimeter of 17,640 linear inches.

1 Kings 6:20

And the oracle in the forepart was twenty cubits in length, and twenty cubits in breadth, and twenty cubits in the height thereof: ...

2 Chronicles 4:1

Moreover he made an altar of brass, twenty cubits the length thereof, and twenty cubits the breadth thereof, and ten cubits the height thereof.

<p>176,400 square inches</p> <div style="border: 1px solid black; padding: 5px; background-color: #ffffcc; margin: 10px auto; width: 80%;"> <p style="text-align: center;">MOST HOLY 20c x 20c</p> <p style="text-align: center;">20c x 20c = 400sc 400sc x 441si* = 176,400si</p> </div>	<p style="text-align: center;">Noah's Ark had a perimeter of 17,640 linear inches. (700 x 25.2" cubit)</p> <div style="text-align: center;">  </div> <p style="text-align: center;">The flood was the destruction of sin. The <u>Brazen Altar</u> and the <u>Most Holy</u> represent the <u>destruction of sin</u>.</p>	<p>176,400 square inches.</p> <div style="border: 1px solid black; padding: 5px; background-color: #ffffcc; margin: 10px auto; width: 80%;"> <p style="text-align: center;">BRAZEN ALTAR 20c x 20c</p> <p style="text-align: center;">20c x 20c = 400sc 400sc x 441si* = 176,400si</p> </div>
--	--	--

*21" x 21" = 441 square inches. (The 21" cubit is used for Solomon's Altar & other things.)

<p>"... the brazen altar was an "altar of continual atonement," representing the putting away and destruction of sin, the only thing that separates us from God and prevents our prayers from being answered." Stephen Haskell, <i>The Cross and it's Shadow</i>, p. 62</p>	<p>"Since it is the sins of mankind that defile the earth, in every sin-offering, after the offering had been made for the sinner, the remainder of the blood was poured out on the ground at the base of the brazen altar in the court, as a type of the precious blood of Christ, which would remove every taint of sin from this earth, and clothe it in Eden beauty." <i>ibid</i>, p. 129</p>
---	---

Note: There are 17,640 prophetic days in the "**sabbaths-of-the-land**" law (see page 20).

8 x 2520 LINEAR INCHES

EZEKIEL'S ALTAR HAS 8 x 2520 LINEAR INCHES

Each platform is measured as a six sided cube.

Perimeter of the top & bottom panels = $480c \times 21'' = 10,080/2520 = 4$

Length-wise edges of the 16 sides = $480c \times 21'' = 10,080/2520 = 4$

Cannot measure the height accurately unless we know how the platforms sit: in or on top of each other?

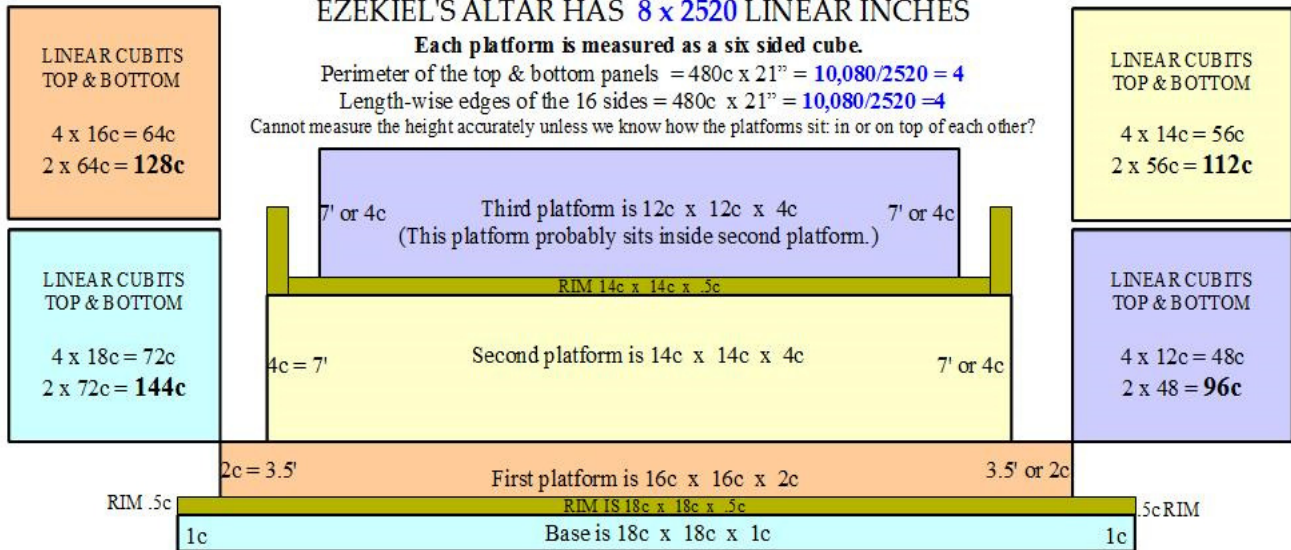

BASE PANELS	FIRST PLATFORM PANELS	SECOND PLATFORM PANELS	THIRD PLATFORM PANELS
$1c$ $18c$ $1c$ $18c$	$2c$ $16c$ $2c$ $16c$	$4c$ $14c$ $4c$ $14c$	$4c$ $12c$ $4c$ $12c$
$1c$ $18c$ $1c$ $18c$	$2c$ $16c$ $2c$ $16c$	$4c$ $14c$ $4c$ $14c$	$4c$ $12c$ $4c$ $12c$
$1c$ $18c$ $1c$ $18c$	$2c$ $16c$ $2c$ $16c$	$4c$ $14c$ $4c$ $14c$	$4c$ $12c$ $4c$ $12c$
$1c$ $18c$ $1c$ $18c$	$2c$ $16c$ $2c$ $16c$	$4c$ $14c$ $4c$ $14c$	$4c$ $12c$ $4c$ $12c$
Length = $8 \times 18c = 144c$ Width = $8 \times 1c = 8c$	Length = $8 \times 16c = 128c$ Width = $8 \times 2c = 16c$	Length = $8 \times 14c = 112c$ Width = $8 \times 4c = 32c$	Length = $8 \times 12c = 96c$ Width = $8 \times 4c = 32c$

2520 SQUARE CUBITS

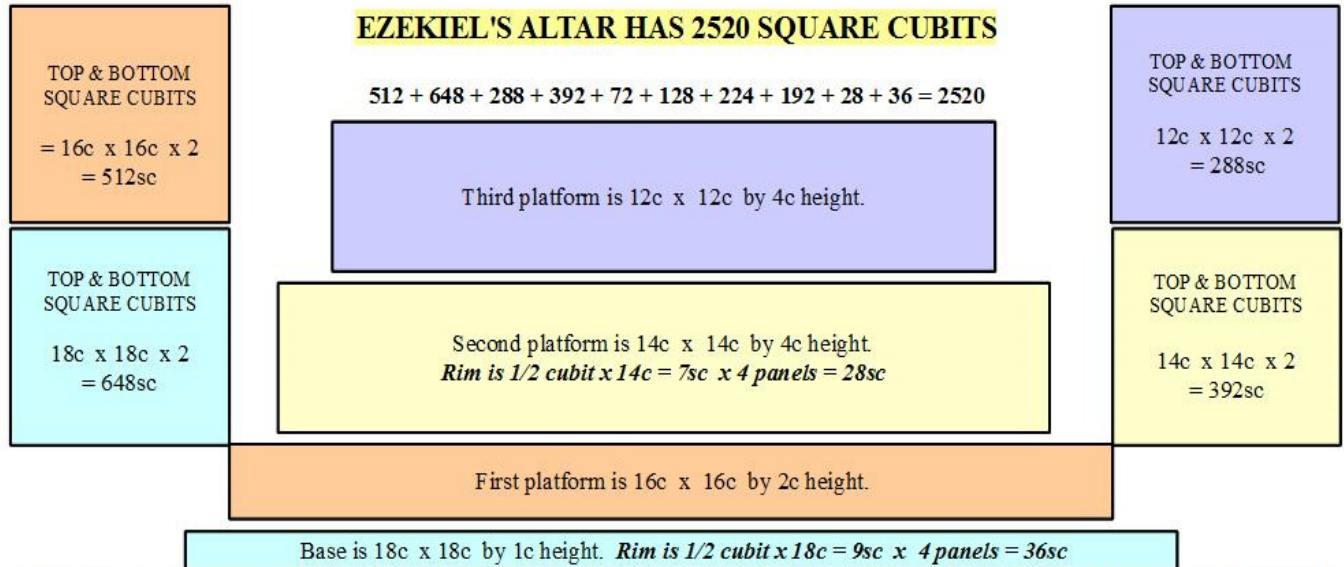

SQUARE OF BASE PANELS	SQUARE OF SIDE PANELS	SQUARE OF SIDE PANELS	SQUARE OF SIDE PANELS
$1 \times 18c = 18sc$	$2 \times 16c = 32sc$	$4 \times 14c = 56sc$	$4 \times 12c = 48sc$
$1 \times 18c = 18sc$	$2 \times 16c = 32sc$	$4 \times 14c = 56sc$	$4 \times 12c = 48sc$
$1 \times 18c = 18sc$	$2 \times 16c = 32sc$	$4 \times 14c = 56sc$	$4 \times 12c = 48sc$
$1 \times 18c = 18sc$	$2 \times 16c = 32sc$	$4 \times 14c = 56sc$	$4 \times 12c = 48sc$
Total = 72sc	Total = 128sc	Total = 224sc	Total = 192sc

CHAPTER 8

BOAZ & JACHIN THE TWO PILLARS

BOAZ = STRENGTH

JACHIN = GOD ESTABLISHES

Before the High Priest can enter the porch (Tower) of the Temple he must first walk between two Pillars which represent the **2520 (2 x 1260)**.

These pillars are hollow and if we roll them out flat, the perimeter measures would be:

$$12c + 12c + 18c + 18c = 60c \times 2 \text{ pillars} = 120c$$

$$120c \times 21'' = \mathbf{2520''}$$

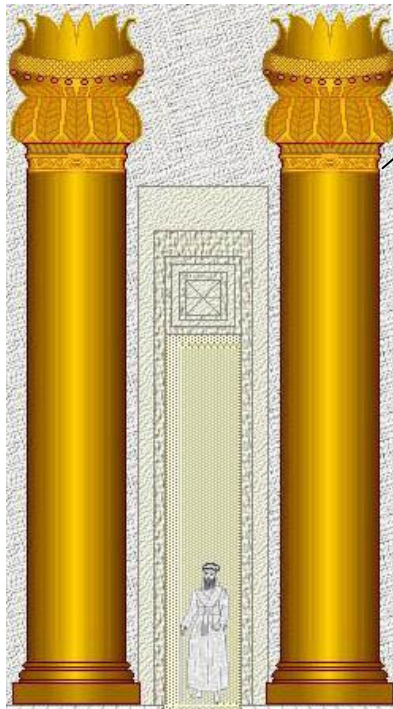

The chapters were not measured for this work.

I Kings 7:15-16 NKJV

And he cast two pillars of bronze, each one *eighteen cubits high*, and a line of twelve cubits measured the circumference of each.

Then he made two capitals of cast bronze, to set on the tops of the pillars. The height of one capital was *five cubits*, and the height of the other capital was *five cubits*. ...

Jeremiah 52:21-23 NKJV

Now concerning the pillars: the height of one pillar was *eighteen cubits*; a measuring line of twelve cubits could measure its circumference, and its thickness was four fingers; it was hollow. A capital of bronze was on it; and the height of one capital was *five cubits*, with a network and pomegranates all around the capital, all of bronze.

2 Chronicles 3:15-17

Also he made before the house two pillars of *thirty and five cubits* high, and the chapter that was on the top of each of them was *five cubits*. v. 16. And he made chains, as in the oracle, and put them on the heads of the pillars; and made an hundred pomegranates, and put them on the chains. v. 17 And he reared up the pillars before the temple, one on the right hand, and the other on the left; and called the name of that on the right hand Jachin, and the name of that on the left Boaz.

2 Kings 25:17 NKJV

The height of one pillar was eighteen cubits, and the capital on it was of bronze. The height of the capital was three cubits, and the network and pomegranates all around the capital were all of bronze. The second pillar was the same, with a network.

CHAPTER 9
THE HIGH TOWER

CHRIST IS OUR HIGH TOWER

"In the parable the householder represented God, the vineyard the Jewish nation and the hedge the divine law which was their protection.

The tower was a symbol of the temple. ..." *The Desire of Ages*, p. 596.



<p>Psalms 18:2 The LORD is my rock, and my fortress, and my deliverer; my God, my strength, in whom I will trust; my buckler, and the horn of my salvation, and my <u>high tower</u>.</p>	<p>The householder "fenced it, and gathered out the stones thereof, and planted it with the choicest vine, and <u>built a tower in the midst</u> of it, and also made a winepress therein: and he looked that it should bring forth grapes, and it brought forth wild grapes." Isaiah 5:2</p>	<p>Psalms 144:2 My goodness, and my fortress; my <u>high tower</u>, and my deliverer; my shield, and he in whom I trust; who subdueth my people under me.</p>
<p>Proverbs 18:10 The name of the LORD is a <u>strong tower</u>: the righteous runneth into it, and is safe.</p>		<p>Psalms 61:3 For thou hast been a shelter for me, and a <u>strong tower</u> from the enemy.</p>
<p>2 Samuel 22:51 He is the <u>tower of salvation</u> for his king: and showeth mercy to his anointed, unto David, and to his seed for evermore.</p>		<p>Habakkuk 2:1 I will stand upon my watch, and set me upon the <u>tower</u>, and will watch to see what he will say unto me, and what I shall answer when I am reproved.</p>

HEROD'S TEMPLE TOWER WAS 100 CUBITS TALL, (20 cubits less than Solomon's 120)

"...Wealth, labor, and architectural skill had for more than forty years been freely expended to enhance its splendors. Herod the Great had lavished upon it both Roman wealth and Jewish treasure, and even the emperor of the world had enriched it with his gifts. Massive blocks of white marble, of almost fabulous size, forwarded from Rome for this purpose, formed a part of its structure; ..."

The Great Controversy, p. 25.



This is a beautiful depiction of Herod's Temple but in reality it must have been much more elaborate.

Ellen White makes a strong statement about the height and magnificence of Herod's Temple, that it was one of the "wonders of the world."

"When the procession reached the brow of the hill, and was about to descend into the city, Jesus halted, and all the multitude with Him. Before them lay Jerusalem in its glory, now bathed in the light of the declining sun.

The temple attracted all eyes. In stately grandeur it towered above all else, seeming to point toward heaven as if directing the people to the only true and living God.

The temple had long been the pride and glory of the Jewish nation. The Romans also prided themselves in its magnificence. A king appointed by the Romans had united with the Jews to rebuild and embellish it, and the emperor of Rome had enriched it with his gifts.

The Desire of Ages, p. 575.

Its strength, richness, and magnificence had made it one of the wonders of the world."

"While the westering sun was tinting and gilding the heavens, its resplendent glory lighted up the pure white marble of the temple walls, and sparkled on its gold-capped pillars. From the crest of the hill where Jesus and His followers stood, it had the appearance of **a massive structure** of snow, set with golden pinnacles. At the entrance to the temple was a vine of gold and silver, with green leaves and **massive** clusters of grapes executed by the most skillful artists. This design represented Israel as a prosperous vine. The gold, silver, and living green were combined with rare taste and exquisite workmanship; as it twined gracefully about the white and glistening pillars, clinging with shining tendrils to their golden ornaments, it caught the splendor of the setting sun, shining as if with **a glory borrowed from heaven.**" Ibid.

Solomon's Temple was even more magnificent!

SOLOMON'S & EZEKIEL'S HIGH TOWER ARE 2520" IN HEIGHT!

& has 10 x 2520 (25,200) in all its linear measures.

(plus 9 x 2520 + 9 x 2450)

When entering or exiting the temple the priests walk under the 2520-high tower.

"And the porch that was in the front of the house, the length of it was according to the breadth of the house, twenty cubits, and ***the height was an hundred and twenty***: and he overlaid it within with pure gold." 2 Chron. 3:4

$$120 \text{ cubits} \times 21\text{-inch cubit} = 2520$$

Seventh-day Adventist Bible Commentary

Vol. 3, p. 217: (emphasis supplied):

"An hundred and twenty. According to 1 Kings 6:2 the height of the Temple was 30 cu. Kings does not give the height of the porch, but the figure here given, 120 cu or 175* ft. (53.3 m.) would provide **a structure unlike anything else known in ancient architecture.**

A porch 20 x 10 x 120 cu. would be actually a tower of skyscraper dimensions. Perhaps 20 cu. is meant in harmony with several manuscripts of the LXX and the Syriac. (see on 1 Kings 6:3)."

(20 cubits tall? *Wrong*. The Holy is 30 cubits in height and the Most Holy is 20 cubits in height.)

*NOTE: Here the SDA commentary series uses the 17.5" cubit.

The Seventh-Day Adventist Bible Commentary
Vol. 8, p. 1097 has this to say (emphasis supplied):

"Many scholars believe that the front of the Temple had either two high monumental towers or **a pylon like entrance.**

The monumental towers find some basis in 2 Chron. 3:4, which speaks of the height of the vestibule, or porch, as 120 cu.

If this figure is correct, **only high towers can be meant.** ..."

Many artists have made drawings of what they perceive Solomon's, Ezekiel's & Herod's Temples to look like. These pictures below do not display the actual beauty, only the magnificent height of the 'high tower.'"

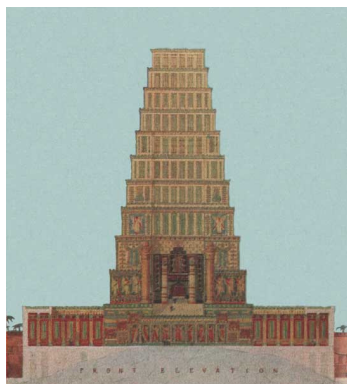

A masonic version of Solomon's Tower.

Ultra modern view of Ezekiel's Tower.

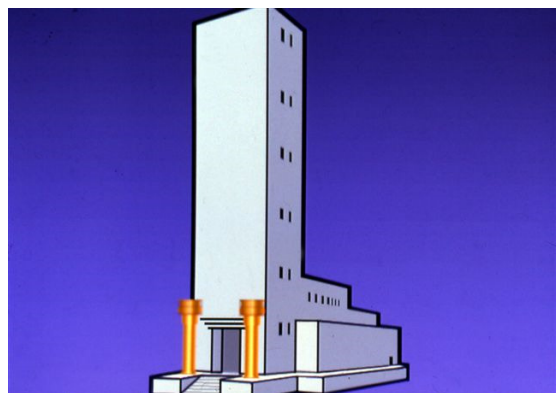

Solomon's and Ezekiel's High Towers (each)

$$\begin{aligned}
 &= 9 \times 2520 + 9 \times 2450 \\
 &= \underline{1 \times 2520} + \underline{9.5 \times 2450} \\
 &= 10 \times 2520 + 18.5 \times 2450
 \end{aligned}$$

1 Chron. 3:4

“And the porch that was in the front of the house, the length of it was according to the breadth of the house, twenty cubits, and the height was an hundred and twenty: and he overlaid it within with pure gold.”

THE HIGH TOWER

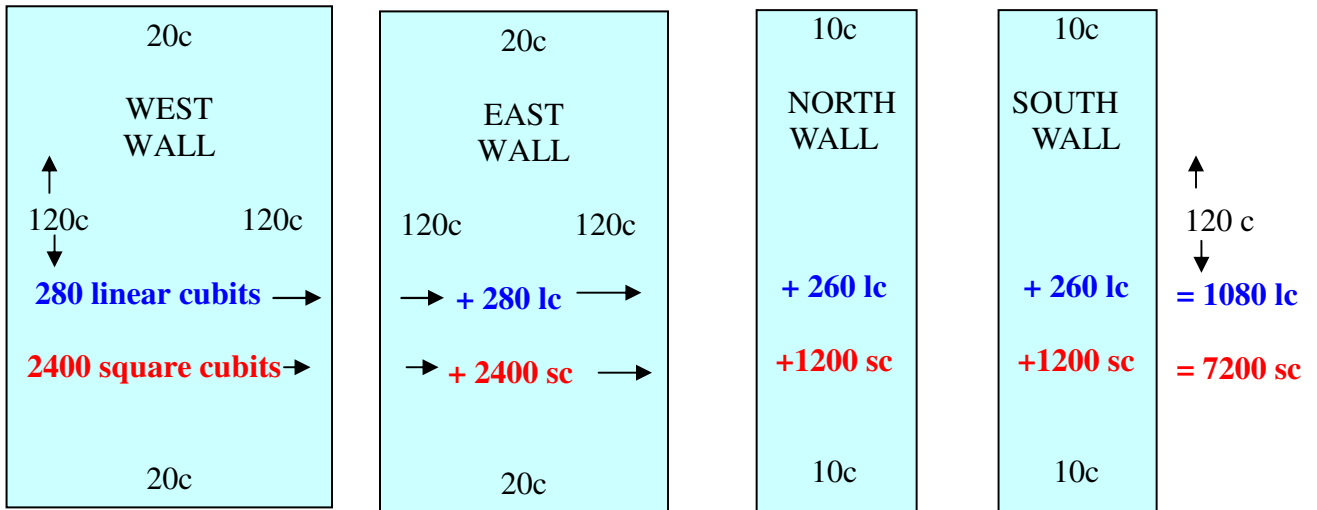

Note: The Holy Place of the Wilderness Tabernacle = 10c x 20c.

The Two Angels in Solomon's Most Holy = 10c x 20c, Zechariah's Roll = 10c x 20c.

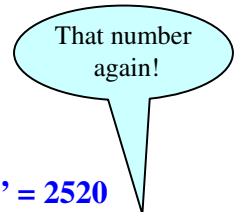
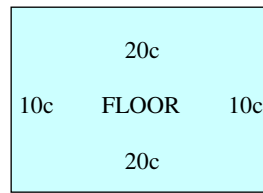
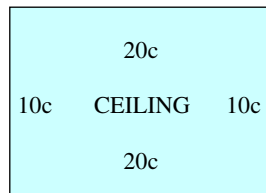

$$\begin{aligned}
 &60 \text{ linear cubits} + 60c = 120c \times 21'' = 2520 \\
 &200 \text{ square cubits} + 200sc = 400sc \times 441si = \underline{176,400}
 \end{aligned}$$

THE CEILING & FLOORS* = 1 x 2520 linear & 1 x 1225 square

The four Walls of the Tower in linear = 1080c x 21" = 22,690" divided by **9 = 9 x 2520**

The four Walls of the Tower in square = 7200 square feet x 441 square inches = 3,175,200si
divided by 144si = 22,050sf divided by **9 = 9 x 2450**

The Floor & the Ceiling in linear = 60c + 60c = 120c x 21" = **1 x 2520**

The Floor & the Ceiling in square = 200sc + 200sc = 400sc x 441si = 176,400si/144si = **1225sf** (1/2 2450)

*The top and bottom edges of the Boards were measured separately from the two long sides. That principle has been demonstrated to be accurate, thus the ceiling and the floor can be measured separately and be used in different sums.

THE DECREE OF CYRUS AND THE 2520

Ezra 6:3

In the first year of Cyrus the king the same Cyrus the king made a decree concerning the house of God at Jerusalem, Let the house be builded, the place where they offered sacrifices, and let the **foundations** thereof be strongly laid; the height thereof **threescore cubits**, and the breadth thereof **threescore cubits**;

Threescore cubits is 60 cubits. This is not the size of the Temple that was rebuilt. Commentators have differing ideas about this, but none can settle it for sure. The SDA Bible Commentary, Volume 3, p. 358 has this statement: "The figure here given for the height of the new Temple is twice that of the Temple of Solomon, and the width three times as great (see 1 Kings 6:2). The length of the new structure is not given; that of Solomon's Temple was 60 cu. Yet the new edifice is said to be "as nothing" in comparison with that of Solomon's (Haggai 2:3), and those who had seen the Temple of Solomon wept when they saw the foundation of the new building, because of the obvious inferiority of the latter (Ezra 3:12; cf. PK 564). ... It may be that the dimension given in Cyrus' decree are for the front of the Temple only, which was of more magnificent proportions than the rest of the building."

Why were these dimensions given without the length?
All that can be done is to add them up (for now).

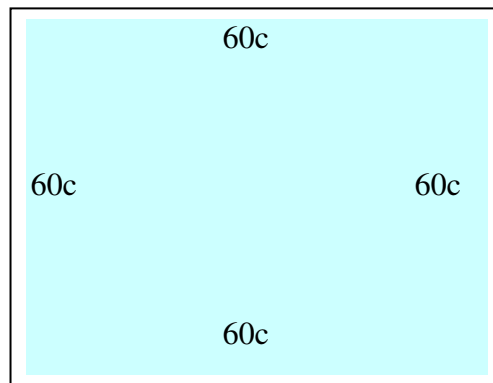

The linear perimeter of $4 \times 60c = 240$ cubits $\times 21''$ cubit = **5040**
or
TWO TIMES 2520

CHAPTER 10

ENTER

INTO HIS SANCTUARY HIS THRONE ROOM

The word “enter” is in the
King James Bible [144](#) times.

EZEKIEL 40:4
DECLARE THE MEASUREMENTS OF THE
TEMPLE TO THE HOUSE OF ISRAEL

"The prophets spoke less for their own time than for the ages which have followed,
and for our own day." *Signs of the Times*, April 2, 1896

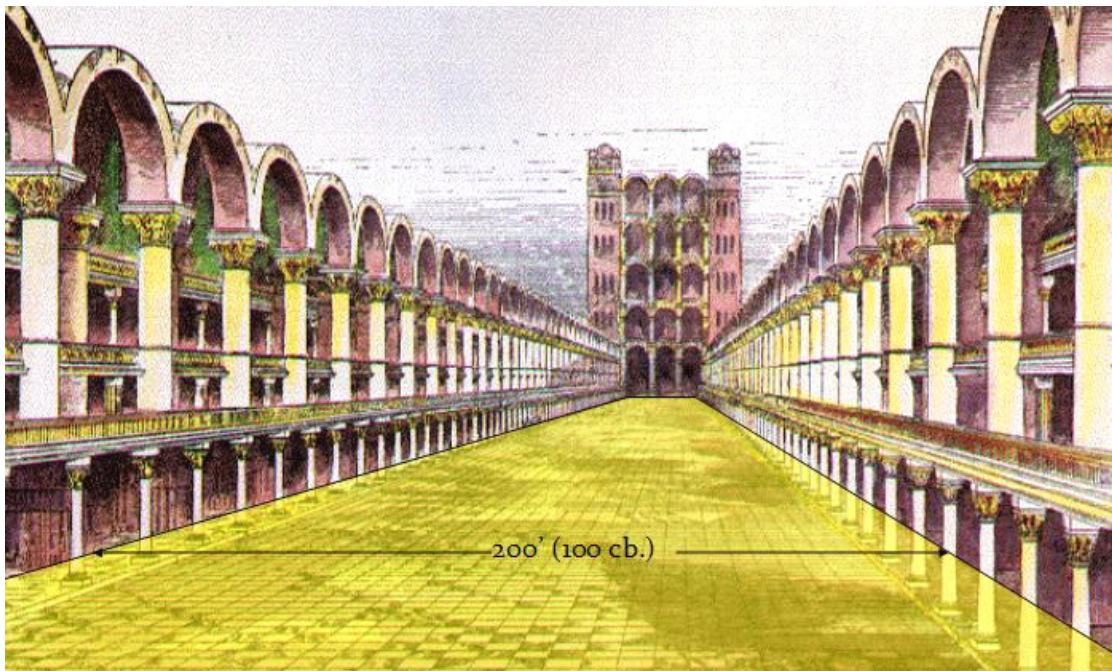

Henry Sulley's depiction of Solomon's Temple and courtyard.
This is a better depiction of the beauty of Solomon's Temple (what might have been?).

"A Greater than Solomon was the designer of the temple; the [wisdom](#) and [glory of God stood there revealed](#). Those who were unacquainted with this fact naturally admired and praised Solomon as the architect and builder; but the king disclaimed any honor for its conception or erection." *Prophets and Kings*, p. 66

THE HOLY & MOST HOLY PLACE OF SOLOMON'S TEMPLE HAVE **THE 2520** HIDDEN IN THEIR MEASUREMENTS

The Holy & Most Holy Place of Ezekiel's unbuilt Temple
have the same measures!



The interior height of the Holy Place is over 52 feet.
This drawing shows the proportion
of the Holy Place compared to a human.

1 Kings 6:2, 7, 16, 19-20; (2 Chron. 3:3-9)

- 6:2 And the house which king Solomon built for the LORD,
the length thereof was *threescore cubits* and the breadth thereof
twenty cubits, and the height thereof *thirty cubits*.
- 6:7 And the house, when it was in building, was built of stone **made ready
before it was brought thither**: so that there was **neither hammer nor ax
nor any tool of iron heard in the house, while it was in building.**
- 6:16 And he built twenty cubits on the sides of the house, both the floor and
the walls with boards of cedar: he even built them for it within, even for
the oracle, even for the most holy place.
- 6:19 And the oracle he prepared in the house within, to set there the ark of the
covenant of the LORD.
- 6:20 And the oracle in the forepart was twenty cubits in length,
and twenty cubits in breadth, and twenty cubits in the height thereof:

THE SECRET 2520 OF HIS TABERNACLE

Psalms 25:14

The [secret of the LORD](#)
is with them that fear him;
and he will show them his covenant.

Psalms 27:5

For in the [time of trouble](#)
he shall hide me in his pavilion:
in the [secret of his tabernacle](#)
shall he hide me;
he shall set me up upon a rock.

Isaiah 45:3

And I will give thee the treasures of
darkness, and hidden riches of
[secret places](#), that thou mayest know
that I, the LORD, which call thee
by thy name, am the God of Israel.

Jeremiah 13:16-17

Give glory to the LORD your God, before he cause darkness,
and before your feet stumble upon the dark mountains, and,
while ye look for light, he turn it into the shadow of death,
and make it gross darkness. But if ye will not hear it,
[my soul shall weep in secret places](#) for your pride; and mine
eye shall weep sore, and run down with tears, because
the LORD's flock [is carried away captive](#) [seven times curse].

Psalms 91:1

He that dwelleth [in the secret place](#) of the most High
shall abide under the shadow of the Almighty.

The name Palmoni appears in the original Hebrew in the biblical book of Daniel. The still widely used King James Version of 1611 refers to Palmoni indirectly as "that certain saint" – "or," as a marginal note from the translators says, "the numberer of secrets, or, the wonderful numberer: Heb. Palmoni."

THE SECRET IN HIS TABERNACLE

$$= 10 \times 2520$$

The Most Holy has 4×2520
and the Holy Place has 6×2520
 $= 10 \times 2520$

THE MOST HOLY 4×2520 FIRST FOUR COMMANDMENTS	THE HOLY PLACE 6×2520 LAST SIX COMMANDMENTS
EACH ONE OF THE TEN COMMANDMENTS IS SYMBOLIZED BY THE NUMBER 2520	

Matthew 22:40

On these two commandments hang all the law and the prophets.

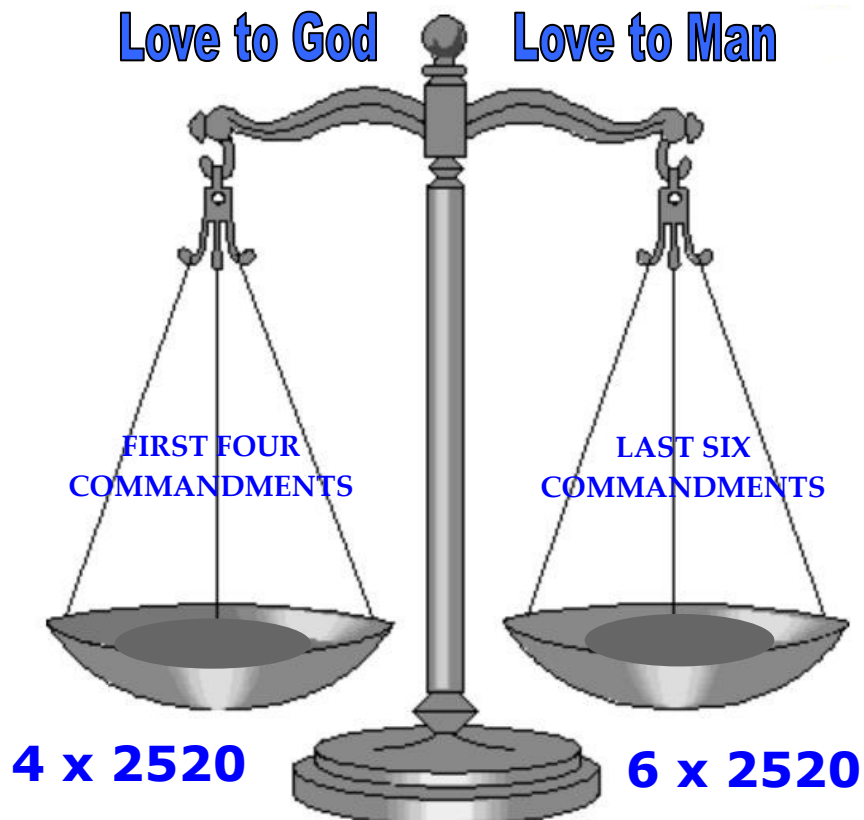

Note: The 70-years captivity was 10×2520 literal days.

THE TEN COMMANDMENTS IS A FIXED STANDARD OF MEASUREMENT

Rev. 11:1 – And there was given me a reed like unto a rod:	Rev. 21:15-16 – And he that talked with me had a golden reed to measure the city,...
<p style="text-align: center;">#2563 – REED</p> <p>NT:2563 kalamos (kal'-am-os); or uncertain affinity; a reed (the plant or its <u>stem</u>, or that of a similar plant); by implication, a pen: KJV - pen, reed.</p>	<p style="text-align: center;">#4464 – REED = ROD and a ROD = SCEPTRE</p> <p>NT:4464 rhabdos (hrab'-dos); from the base of NT:4474; a stick or wand (as a cudgel, a cane or a baton of royalty): KJV - rod, sceptre, staff.</p>

The prophet was told to “measure” with a Sceptre (rod, reed).
The “measure” is a fixed standard of measurement.
Sceptre/Rod/Throne = Righteousness = Ten Commandments.

<p style="text-align: center;">MEASURE #3354</p> <p>Rev. 11:1 – Rise and <u>measure</u> the Temple of God and the Altar.</p> <p>NT:3354 metreo (met-reh'-o); from NT:3358; to measure (i.e. ascertain in size by <u>a fixed standard</u>); by implication to admeasure (i.e. allot by rule): KJV - figuratively, to estimate: KJV - measure, mete.</p>	<p>Heb 1:8-9 – But unto the Son he saith, <u>Thy throne</u>, O God, is for ever and ever: a <u>sceptre of righteousness</u> is the <u>sceptre</u> of thy kingdom. Thou hast loved righteousness, and hated iniquity; ...</p> <p>Psalms 45:6 <u>Thy throne</u>, O God, is for ever and ever: <u>the sceptre</u> of thy kingdom is a <u>right sceptre</u>.</p> <p>Ps 47:8 God reigneth over the heathen: God sitteth upon the throne of his holiness [qodesh, Most Holy].</p>
---	--

“[The] unchangeable law of God, is the foundation of his throne, the transcript of his character.”
Ellen White, *The Bible Echo*, Feb. 19, 1894

A Reed is a Rod, and a Rod is a Sceptre,
and a Sceptre is the Throne/Qodesh of God
above the Ark of the Covenant containing the
Law of His character/His righteousness/His Holiness,
the law of love, the *Ten Commandments*, which is
a fixed measure (2520) of a Rod which is a Reed.

THE TEMPLE WAS BUILT ACCORDING TO THE BLUEPRINT GIVEN BY GOD

Linear cubits = **10 x 2520**

1 Kings 5:18 – And Solomon's builders and Hiram's builders did hew them,
and the stonesquarers: so they prepared timber and stones to build the house.

1 Kings 6:7 – And the house, when it was in building,
was built of stone **made ready before** it was brought thither:

**It was measured, cut or hewn and then later assembled at the Temple Mount,
so we will take it apart and re-measure.**

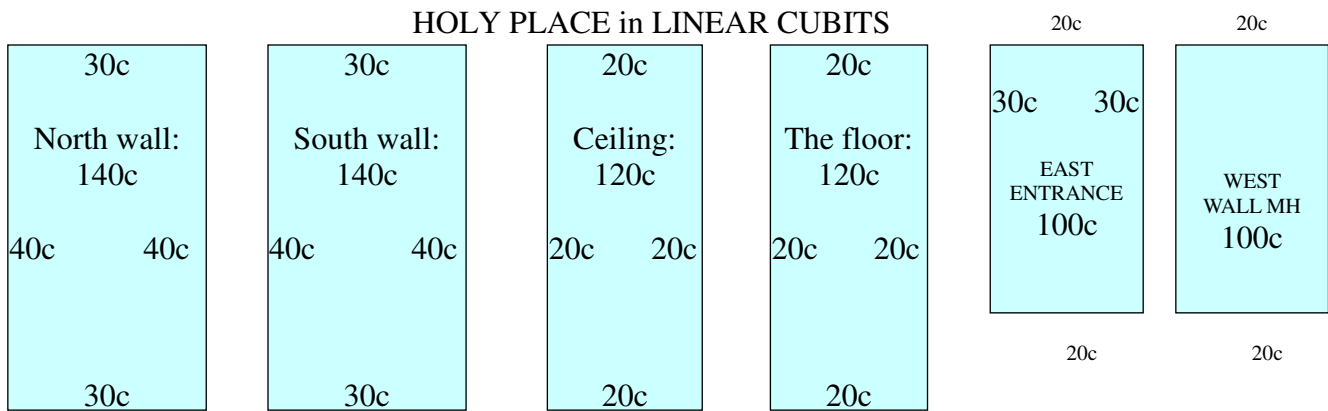

$$140c + 140c + 120c + 120c + 100c + 100c = 720c \times 21'' = 15,120/2520 = \mathbf{6 \times 2520}$$

MOST HOLY -- LINEAR CUBITS OF EACH SECTION

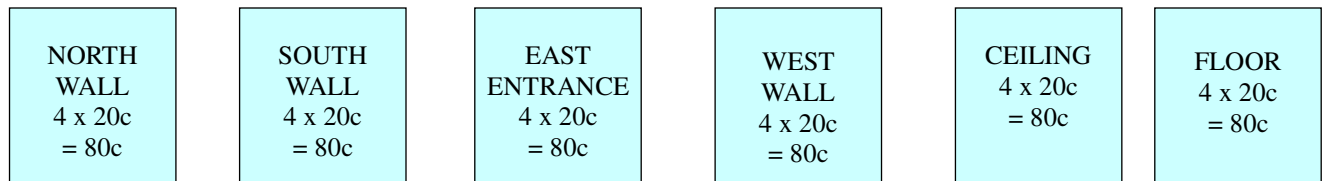

$$80c + 80c + 80c + 80c + 80c + 80c = 480c \times 21'' = 10080/2520 = \mathbf{4 \times 2520}$$

Total is: $720c + 480c = 1200c \times 21'' = \mathbf{25,200}$
divided by **2520 = 10 x 2520**

Note: $10 \times 2520 = 25,200$ is the same as the 70-years captivity $\times 360 = 25,200$.

**The square feet of Solomon's & Ezekiel's
Most Holy & Holy Places = 9 x 2450sf**

The Most Holy has 3 x 2450 square feet.

The Holy Place has 6 x 2450 square feet.

HOLY PLACE in SQUARE CUBITS

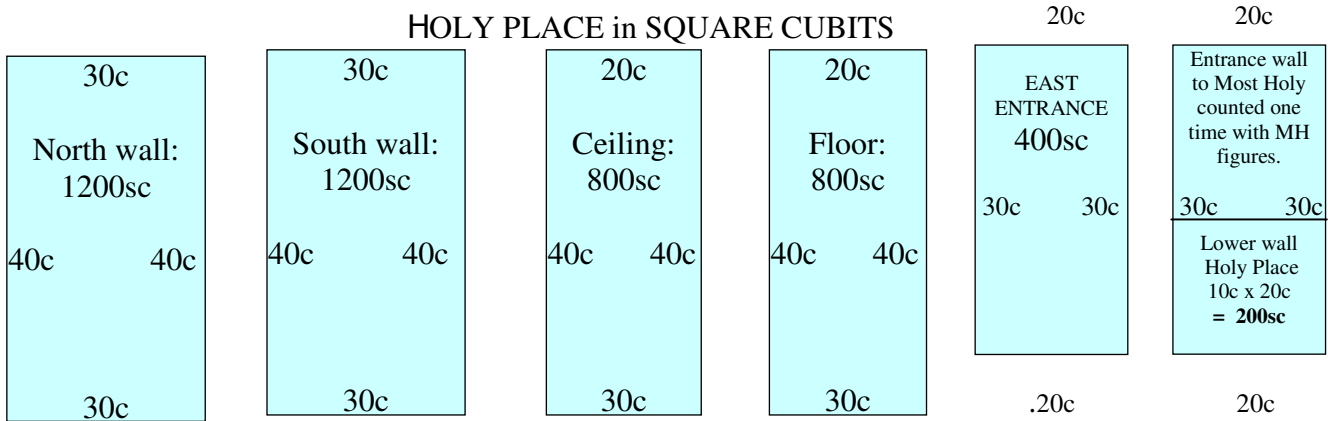

$$1200sc + 1200sc + 800sc + 800sc + 600sc + 200sc = 4800sc$$

$$4800sc \times 441si = 2,116,800si \text{ divided by } 144si = 14,700sf$$

$$14,700sf \text{ divided by } 2450sf = 6 \times 2450sf$$

MOST HOLY -- SQUARE CUBITS OF EACH SECTION

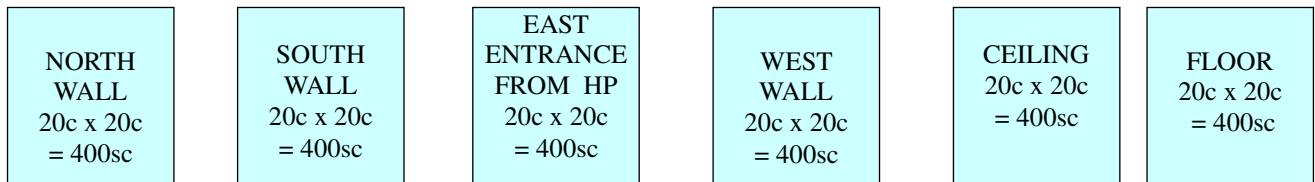

$$400sc + 400sc + 400sc + 400sc + 400sc + 400sc = 2400sc$$

$$2400sc \times 441si = 1,058,400si \text{ divided by } 144sf = 7350sf$$

$$7350sf \text{ divided by } 2450sf = 3 \times 2450sf$$

Rise, and measure the Temple of God AND THE ALTAR.

Rev. 11:1

"The Brazen Altar represents the putting away and destruction of sin, ..."
Stephen Haskell, *The Cross and it's Shadow*, p. 62

9 + 2 = 11 in the two Altars:
Ezekiel's Altar has 9 x 2520.
Together both Altars have 11 x 2520

<p>SOLOMON'S BRAZEN ALTAR</p> <p>2 x 2520'' 1 x 2450sf</p>	<p>SOLOMON'S MOST HOLY</p> <p>4 x 2520'' 3 x 2450sf</p>	<p>SOLOMON'S HOLY PLACE</p> <p>6 x 2520'' 6 x 2450sf</p>	<p>= 12 x 2520 linear in. = 10 x 2450 sq. ft.</p>
<p>EZEKIEL'S BRAZEN ALTAR</p> <p>8 x 2520'' 1 x 2520sc</p>	<p>EZEKIEL'S MOST HOLY</p> <p>4 x 2520'' 3 x 2450sf</p>	<p>EZEKIEL'S HOLY PLACE</p> <p>6 x 2520'' 6 x 2450sf</p>	<p>= 18 x 2520 linear in. = 9 x 2450 sq. feet = 1 x 2520 sq. cubits</p>

This work of measuring is not exhaustive. There is much more information to be gleaned from measuring the Temples, especially Ezekiel's.

**The connections between the
The Twin Towers of the Bible, The Twin Towers of 9/11,
The Altar of Sacrifice, Rev. 10 & 18, the 2450 and the 2520**

Walk about Zion, and go round about her: *tell* [# 5608 - **count - number**] **the towers** thereof. Mark ye well her bulwarks, consider her *palaces* [#759 - **elevations**]; that *ye may tell* [5608-**count - number**] it to the *generation following*. For this God is our God for ever and ever: he will be our guide even unto death. Psalm 48:12-14

<p>And there was given me a reed like unto a rod: and the angel stood, saying, <i>Rise</i>, and <i>measure</i> the temple of God, and the altar, and them that worship <i>therein</i>. Rev. 11:1</p>	<p>Thou son of man, show the house to the house of Israel, that they may be ashamed of their iniquities: and let them <i>measure</i> the pattern. Eze. 43:10</p>
--	---

The High Tower is attached to the front of the Temple
and is the first section of the Temple measured.

<p style="text-align: center;">9-11</p> <p>Each Temple Tower has 9 x 2520 The TWO TOWERS = 2 x 9 = 18 x 2520 (see page 113)</p> <p>The two Altars have a total of 11 x 2520 (see pages 100-107)</p> <p>The Holy & Most Holy have 10 x 2520 (see page 121)</p>	<p style="text-align: center;">ANOTHER 9 x 2520</p> <p style="text-align: center;"><u>Perimeter of Temple + Gates</u></p> <p>Perimeter of Temple (incl. Tower) 70 + 70 + 20 + 20 = <u>180c</u></p> <p>Each Gate: 50 + 50 + 25 + 25 = 150c Perimeter of 6 Gates: 6 x 150c = <u>900c</u></p> <p>Add the Gates perimeter to the perimeter of the Temple: 900c + 180c = 1080 linear cubits x 21-inch cubit = 22,680". 22,680 divided by 2520 = 9 x 2520 Perimeter of the Two Temples = 18 x 2520</p>
---	---

49 x 2520

There are 2450 years in 49 Jubilee cycles.
 Each Jubilee cycle of 49 years has 2520 literal days the land was to have a sabbath rest (see page 19)

This is represented by the 49 x 2520 when the measures of the Towers, Altars and Sanctuaries are combined.

Two Towers = 18 x 2520
 Two Altars = 11 x 2520
 Two Sanctuaries = 20 x 2520

Total = 49 x 2520

49 x 2450

Solomon's Temple: 9 x 2450
 Ezekiel's Temple: 9 x 2450
 Solomon's Altar: 1 x 2450
 Ezekiel's Altar: 0 x 2450
 Solomon's Tower: 9 x 2450
 Ezekiel's Tower: 9 x 2450
 Solomon's Vestibules: 6 x 2450
 Ezekiel's Vestibules: 6 x 2450

Total = 49 x 2450

Leviticus 25:8

And thou shalt number seven sabbaths of years unto thee, seven times seven years; and the space of the seven sabbaths of years shall be unto thee forty and nine years.

Dan. 9:25

Know therefore and understand, that from the going forth of the commandment to restore and to build Jerusalem unto the Messiah the Prince shall be seven weeks, ...
 (7 x 7 = 49)

THE 2520 IS THE FOUNDATION OF HIS THRONE, AND THE FOUNDATION FOR HIS SPIRITUAL TEMPLE

1843 CHART

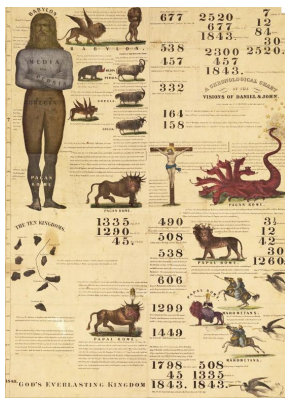

FIRST TWO ANGELS MESSAGES

"By pen and voice we are to sound the proclamation, showing their order and the application of the prophecies, that bring us to the third angels message. ..."

E. G. White, *Selected Messages*,
 Vol. 2, 104

THE SCROLL UNROLLS

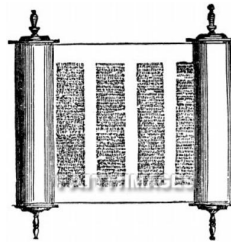

The first chart, the 1843 CHART, has all the FOUNDATIONS of Adventism.

To the 1850 CHART, were added the PILLARS of this movement that came to light after 1844.

1850 CHART



ALL THREE ANGELS MESSAGES

"... there cannot be a third without the first and second. These messages we are to give to the world, in publications, in discourses, showing in the line of prophetic history, the things that have been, and the things that will be." Ibid.

REVELATION 14:6-12

THE THREE ANGELS MESSAGES SYMBOLIZED BY THE PLATFORMS OF EZEKIEL'S ALTAR

THE BASE OF 4 x 18 CUBITS IS THE ANGEL & VOICE OF REV. 18

"I saw a company who stood well guarded and firm, giving no countenance to those who would unsettle the established faith of the body. God looked upon them with approbation.

I was shown **three steps--one, two and three--** the **first, second, and third angels' messages.**" {1SG 168.2}

"...God had led them along **step by step**, until He had placed them **upon a solid, immovable platform**. I saw individuals approach the platform and ***examine the foundation***. ***Some with rejoicing immediately stepped upon it***. Others commenced to find fault with the foundation. ...But I saw that nearly all stood firm upon the platform and exhorted those who had stepped off to –

– cease their complaints; for God was the **Master Builder**, and they were fighting against Him. They recounted the wonderful work of God, which had led them to the ***firm platform***, and in union raised their eyes to heaven and with a loud voice glorified God." Ibid.

This affected some of those who had complained and left the platform, and they with ***humble look again stepped upon it***."

"I AM" SENT HIS ANGELS FROM HIS 2520 THRONE:

THE FIRST ANGEL OF REV. 14:6-7: Fear God and give Glory to Him ...

Having therefore these promises, dearly beloved, let us cleanse ourselves from all filthiness of the flesh and spirit, perfecting holiness in the fear of God. 2 COR. 7:1

THE SECOND ANGEL OF REV. 14:8: Babylon is fallen, is fallen ...

Be ye not unequally yoked together with unbelievers: for what fellowship hath righteousness with unrighteousness? and what communion hath light with darkness? 2 COR. 6:14

THE THIRD ANGEL OF REV. 14: 9-11: If any man worship the beast ...

Wherefore come out from among them, and be ye separate, saith the Lord, and touch not the unclean thing; and I will receive you, ... 2 COR. 6:17

"I AM, THAT I AM"
put the 2520 in the dimensions of Noah's Ark, the three Sanctuaries, and the Altars.

"I AM, THAT I AM"
abides on the throne (qodesh) of His holiness surrounded by the 2520.

THE BLESSINGS FOR KEEPING I AM'S LAW OF LOVE

Psalms 91: 1-16
He that dwelleth ***in the secret place*** of the most High ***shall abide under the shadow*** of the Almighty.
I will say of the LORD, He is my refuge and my fortress: my God; in him will I trust.

Psalms 91: 9-11
Because thou hast made the LORD, which is my refuge, even the most High, thy habitation; There shall no evil befall thee, ***neither shall any plague come nigh thy dwelling***. For he shall give his angels charge over thee, to keep thee in all thy ways.

THE CURSE
FOR BREAKING IAM'S LAW OF LOVE

Rev. 14:9-11

And the third angel followed them, saying with a loud voice, If any man worship the beast and his image, and receive his mark in his forehead, or in his hand, The same shall drink of the wine of the wrath of God, which is poured out without mixture into the cup of his indignation; and he shall be tormented with fire and brimstone in the presence of the holy angels, and in the presence of the Lamb: And the smoke of their torment ascendeth up for ever and ever: and they have no rest day nor night, who worship the beast and his image, and whosoever receiveth the mark of his name.

Rev. 16:1

And I heard a great voice out of the temple saying to the seven angels,
Go your ways, and pour out the vials of the wrath of God upon the earth.

The square of the courtyard hangings divided by the
square of the Breastplate of Righteousness = **6,000 years**.

"Those who are destroying the earth have had a long probation. For *six thousand years* God has borne with the *ignorance and wickedness* of men. In every possible way He has tested and tried them, seeking to lead them to return to their loyalty, and be saved. But they refuse to listen to His entreaties. War and bloodshed have been, are still, and will continue to be. War is popular. To kill and destroy is in the sight of the world to be brave, worthy of a reward." {1MR 61.3}

Exodus 27: 9-18

- 27:9 And thou shalt make the court of the tabernacle: for the south side southward there shall be hangings for the court of fine twined linen of an *hundred cubits long* for one side:
27:11 And likewise for the north side in length there shall be hangings of an *hundred cubits long*, ...
27:12 And for the breadth of the court on the west side shall be hangings of *fifty cubits*: ...
27:13 And the breadth of the court on the east side eastward shall be *fifty cubits*.
27:14 The hangings of one side of the gate shall be *fifteen cubits*: ...
27:15 And on the other side shall be hangings *fifteen cubits*: ...
27:16 And for the *gate* of the court shall be an hanging of *twenty cubits*, ...
27:18 The length of the court shall be an hundred cubits, and the breadth fifty every where, and *the height five cubits* ...

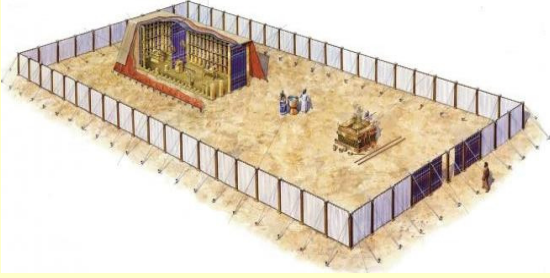

The length of the Courtyard Hangings is 300c.
The height is 5c.

The square of 300c x 5c is 1500sc.
 $1500sc \times 324si (18'' \times 18'') = 486,000si.$

Divide the sum of 486,000 by the square of
 $9'' \times 9'' = 81''$ (Breastplate of Righteousness)
and the sum is 6,000.

A cubit can equal years according to the
Seventh-day Adventist Bible Commentary,
Vol. 8, 252.

The 7th millennium is about to arrive!

NOTES

CHAPTER 11

HISTORICAL PERSPECTIVE

The advent movement of 1840-44 was a
glorious manifestation of the power of God;
Great Controversy, p. 611

IN *THE GREAT CONTROVERSY*,
ELLEN WHITE REFERS TO
"A WARNING PROPHECY".

GREAT CONTROVERSY p. 32

"The hands of the pitiful women have sodden their own children: they were their meat in the destruction of the daughter of my people." Isaiah 49:15; Lamentations 4:10. Again was fulfilled the warning prophecy given fourteen centuries before: "The tender and delicate woman among you, which would not adventure to set the sole of her foot upon the ground for delicateness and tenderness, her eye shall be evil toward the husband of her bosom, and toward her son, and toward her daughter, . . . and toward her children which she shall bear: for she shall eat them for want of all things secretly in the siege and straitness, wherewith thine enemy shall distress thee in thy gates." Deuteronomy 28:56, 57.

**THE WARNING *PROPHECY*
GIVEN 14 CENTURIES EARLIER**

First mention: LEVITICUS 26: 28-29

- 28 - Then I will walk contrary unto you also in fury; and I, even I, will chastise you **seven times** for your sins.
29 - And ye shall eat the flesh of your sons, and the flesh of your daughters shall ye eat.

Second mention: Deut. 28:57

- 57 - ... for **she shall eat them** for want of all things secretly in the siege and straitness, ...

Ellen White understood the 2520 to be an established truth.

The 2520 was one of the foundational truths established during the First & Second Angels messages (1840-44).

“It is God's plan to give sufficient evidence of the divine character of His work to convince all who honestly desire to know the truth. But He never removes all opportunity for doubt. All who desire to question and cavil will find occasion.

No amount of evidence will convince men of the truth so long as they are unwilling to yield their pride, subdue their carnal nature, and become learners in the school of Christ.” *Selected Messages*, vol. 1, p. 72

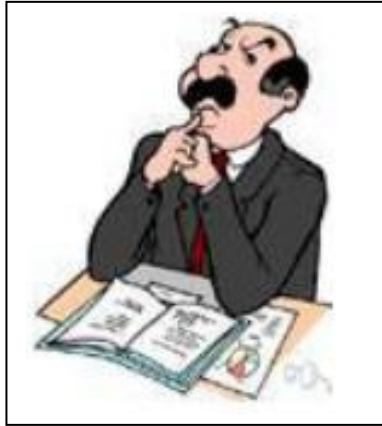

1844 – 1856 – 1863 – 1888

The 2520, 2450, 2300 (and others) were the present truth messages of the First and Second Angels, during the first application of the parable of the Ten Virgins (Matt. 25) during the years 1798 - 1844. This parable prophesied of the experience of the Advent believers up to the time of the Great Disappointment on Oct. 22, 1844. At that time the wheat and tares were separated at the great test of their faith. Those who lost their confidence in God's leading in their experience up to the great test walked no more with the people of God. By their lack of faith they pronounced judgment upon themselves while still living. The judgment of the dead also began at that time, and the churches who had closed their doors to the messages became Apostate Protestantism.

By 1856 the Advent movement had become self-satisfied Laodicea, and in 1863, as a consequence of this condition, James White, overworked and worn out, produced a new chart that did not show the prophecies of the 2520, 1290, 1260 or 1335. The two older charts were set aside as not important or useful, and the 2520-year prophecy was soon forgotten.

Job 12:25

They grope in the dark without light, and he maketh them to stagger like a drunken man.

A natural consequence of the rejection of God's truth and light was darkness. Jesus said: "Walk while ye have the light, lest darkness come upon you: for he that walketh in darkness knoweth not whither he goeth." This condition was especially demonstrated during the 1888 General Conference 25 years later, when the Angel of Rev. 18 was rejected by leaders and laymen who were also rejecting the gift of prophecy given through E.G. White. That history is well known among Adventists, but that dark episode, being the natural aftermath of stepping off of the 2520 foundation laid by our pioneers, was sealed up until recently. Now we have come to understand that "The sins of the

fathers [has been] visited upon the children until the third and fourth generation of them that hate me;" (Ex. 20:5; 34:7; Num. 14:18; Dt. 5:9).

"In rejecting the message given at Minneapolis, men committed sin.
They have committed far greater sin by retaining for years the same hatred against
God's messengers, by rejecting the truth that the Holy Spirit has been urging home. ..."
Ellen G. White, *1888 Materials*, p. 913 (written in 1891).

"The enemy has men in our ranks through whom he works, that the light which God has permitted to shine upon the heart and illuminate the chambers of the mind may be darkened." R&H, August 19, 1890 par. 4

We are now in the spiritual "fourth generation" since 1888, and the light of Present Truth (including the 2520) is shining in the darkness of blinded Laodicea.

The Holy Spirit is the Spirit of Truth, and the 2520 is part of that Truth containing a warning message for Laodicea.

The Truth of God's Word, especially prophecy, convict the heart (Eze. 37), and put enmity (Gen. 3:15) into the mind.

**The 2520 represents the character of God as revealed in His law, the Ten Commandments.
There is no reason for the great animosity demonstrated towards the 2520 today
except that it is doing just what God promised back in Eden in Gen. 3:15:**

**"And I will put enmity between thee and the woman,
and between thy seed and her seed; ... "**

NOTES

CHAPTER 12

THE CREATOR OF MATHEMATICS

PALMONI (Dan. 8:13) IS THE "WONDERFUL NUMBERER"

7 divided into 2520 = 360. 360 divided into 2520 = 7.

But 7 does not divide into 360!

360 divided by 7 = 51.428571

"There are four great sciences ...of these sciences the gate and key is mathematics, which the saints discovered at the beginning of the world." Roger Bacon

"God wrote the universe in the language of mathematics"....Galileo

"We've all seen those math formulas in which gravity, force, acceleration and everything else can be expressed with just a few variables. Why should that be? Why should things not be a hopeless mishmash, like our sock drawer? The answer is what Galileo said...God wrote the universe, and he used mathematics as a language. ..."

"Contrary to popular belief, those early scientists really didn't experiment much. Instead, they worked out the math, since they were convinced that was how God designed things."

Many of the particulars here are found in the book *Mathematics and the Search for Knowledge*, by Morris Kline.

The laws of nature are but the mathematical thoughts of God. (Euclid)

All the pictures which science now draws of nature and which alone seem capable of according with observational fact are mathematical pictures. ... From the intrinsic evidence of his creation, the Great Architect of the Universe now begins to appear as a pure mathematician. (Jeans)

Revelation 9:15, "...an hour, day, month and year."

<p>Aug. 11, 1840</p> <p>The 391-year 15-day prophecy is fulfilled.</p> <p><u>Islam is restrained.</u></p> <p>The Angel of Rev.10 descends</p> <p>"In the year 1840 another remarkable fulfillment of prophecy excited widespread interest." GC 335.</p>	<p>Sept. 11, 2001</p> <p>After the attack on the World Trade Center,</p> <p><u>Islam is restrained.</u></p> <p>The Angel of Rev. 18 descends.</p> <p>The sprinkling of the latter rain begins.</p>
<p>August 11, 1840 is linked to Sept. 11, 2001 by a mathematical equation designed by the Creator.</p>	

**Multiply the year/number 2001 by the prophetic “key” number of 360,
and then divide by the year/number 1840:**

2001 x 360 = 720360. Divide by 1840 = 391.5

The half - year (.5) is reckoned by the Jewish religious calendar which begins in March/April. August is 6 months later. This equation shows us August of 1840 is the fulfillment of the prophecy of Rev. 9:15, and links it with Sept. 11, 2001.

Time “will never again be a test.” {EW 74} but is this just an interesting coincidence?

Palmoni, the *Wonderful Numberer* in Ezekiel 4

Genesis 6:3 And the LORD said, My spirit shall not always strive with man, for that he also is flesh: yet his days shall be an hundred and twenty years (1).

Ezekiel 4:4-6, 10-11

04 Lie thou also upon thy left side, and lay the iniquity of the house of Israel upon it: according to the number of the days that thou shalt lie upon it thou shalt bear their iniquity.

05 For I have laid upon thee the years of their iniquity, according to the number of the days **390 days**: so shalt thou bear the iniquity of the house of Israel.

06 And when thou hast accomplished them, lie again on thy right side, and thou shalt bear the iniquity of the house of Judah **40 days: I have appointed thee each day for a year.**

10 And thy meat which thou shalt eat shall be by weight, **20 shekels a day**: from time to time shalt thou eat it.

11 Thou shalt drink also water by measure, the **6th part of an hin**: from time to time shalt thou drink.

The “day for a year” principle is set forth in Eze.4:6. The “day for a year” principle is how the SDA church interprets and understands the prophecies of Daniel. That “day for a year” is a Biblical/prophetic 360 days per year.

Palmoni put the number 126 in these figures for the “wise virgins” of the last days to understand. But first, notice the number 360!

Verse 5:

SPIRITUAL APPLICATION FOR THE 390 DAYS (YEARS):

390 days = 390 spiritual/prophetic years. 390 years x 360 Biblical days per year = 140,400 days.

a) 140,400 days with 20 shekels a day = a spiritual **2,808,000** shekels.

b) 140,400 days with 1/6 hin of water each day = a spiritual **23,400** full hins of water (140,400/6 = 23,400).

Note: The shekels divided by the water (2,808,000/23,400) = **120(1)**. Shekels = Man(2); Water = Holy Spirit.

LITERAL APPLICATION FOR THE 390 DAYS:

390 literal days:

- a) 390 days x 20 shekels a day = a literal **7800** shekels.
 - b) 390 days with 1/6 hin each day divided by 6 (a full hin) = a literal **65** full hins (390/6 = 65).
- Note: The shekels divided by the water (7800/65) = **120**.

The spiritual shekels (2,808,000) divided by the literal shekels (7800) = 360:

(2,808,000 divided by 7800 = 360.)

The spiritual hins of water (23,400) divided by the literal hins of water (65) = 360:

(23,400 divided by 65 = 360)

Verse 6:

SPIRITUAL APPLICATION FOR THE 40 DAYS (YEARS):

40 days = 40 spiritual/prophetic years. 40 years x 360 Biblical days per year = 14,400 days.

- a) 14,400 days with 20 shekels a day = **288,000 shekels (2 x 144,000)**.
 - b) 14,400 days with 1/6 hin of water each day = **2400** full hins of water (14,400/6 = 2400).
- Note: 288,000 shekels divided by 2400 hins of water = 120.

LITERAL APPLICATION FOR THE 40 DAYS:

40 literal days:

- a) 40 days x 20 shekels a day = **800** shekels.
 - b) 40 days with 1/6 hin of water each day divided by 6 (a full hin) = **6.66** full hins.
- Note. The 800 shekels divided by 6.66 hins of water = 120.1201201201201

The spiritual shekels (288,000) divided by the literal shekels (800) = 360:

(288,000 spiritual shekels divided by 800 literal shekels = 360)

The spiritual hins of water (2400) divided by the literal hins of water (6.66) = 360.3603603604

(2400 hins of water divided by 6.66 = 360.3603603604)

- 1 120 is the symbolic number for probationary time. Noah preached for 120 years, then the floods came (Gen. 6.3).
- 2 Exodus 30:12-13
- 3 Judah resisted the Holy Spirit (water), and received a spiritual "mark of the beast" instead.

ZECHARIAH'S ROLL = 2520, 2450, 2300

The flying roll symbolizes the first angel's message "flying through the midst of heaven proclaiming with a loud voice" (Rev 14:6,7) which William Miller saw (upon awaking out of sleep and seeing the candlesticks and two witnesses) represented the several time prophecies pointing forward to 1844: the 2300, 2450, and 2520.

Then I turned, and lifted up mine eyes, and looked, and behold a flying roll. And he said unto me, What seest thou? And I answered, I see a flying roll; the length thereof is **twenty cubits, and the breadth thereof ten cubits**. Then said he unto me, This is the curse that goeth forth over the face of the whole earth: for every one that **stealeth** shall be **cut off** as on this side according to it; and every one that **swaureth** shall be **cut off** as on that side according to it.

Zech. 5:1-3

The "swaureth" & "stealeth" give us a clue this represents the first four and last six commandments.

THE 2300 DAYS LINKED TO THE ROLL

Strong's definition of "**shall be cut off**": (signifies the work beginning at the end of the 2300 days). OT:5352 naqah (naw-kaw'); a primitive root; **to be (or make) clean** (literally or figuratively); by implication (in an adverse sense) to be bare, i.e. extirpate KJV - acquit at all, altogether, **be blameless, cleanse**, (be) clear (-ing), cut off, be desolate, be free, be (hold) guiltless, be (hold) innocent, by no means, be quit, be (leave) unpunished, utterly, wholly.

THE TEN COMMANDMENTS LINKED TO THE ROLL

Ellen White in the book *Education*, p. 144, quotes Zechariah 5:1-4 then says this: "Against every evildoer God's law utters condemnation [a curse]. ... It destroys his peace. If unheeded, it pursues him to the grave. It bears witness against him at the judgment. A quenchless fire, it consumes at last soul and body."

REV. 14:6-7 - THE FIRST ANGELS MESSAGE LINKED TO THE ROLL

"The Spirit who asked Zechariah, 'What seest thou?' to which he answered, 'I see a flying roll,' also caused an angel to fly in the midst of heaven, 'having the everlasting gospel to preach unto them ...' Many indeed will not understand,

but will stumble at the words contained in the roll." Ellen White, *The New York Indicator*, Feb. 7, 1906

BOTH SIDES OF THE ROLL HAVE A TOTAL PERIMETER OF 2520 LINEAR INCHES

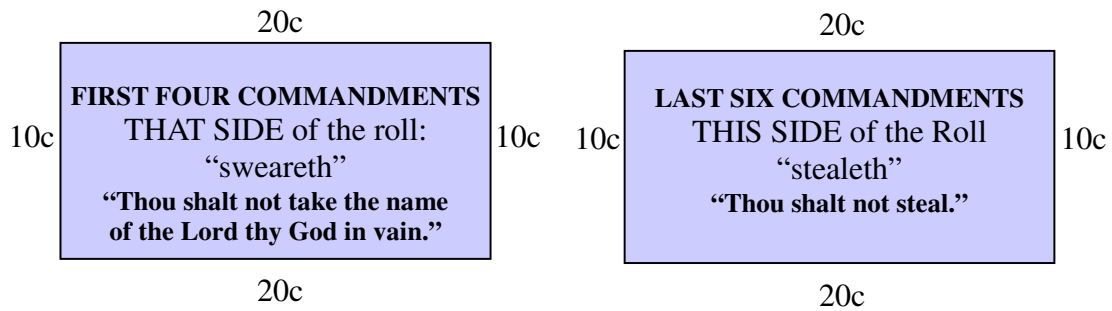

Perimeter of "that side" is 60c x 21"

Perimeter of "this side" is 60c x 21"

= 1260" = PAGANISM

= 1260" = PAPALISM

EACH SIDE OF THE ROLL HAS A SQUARE OF 2450

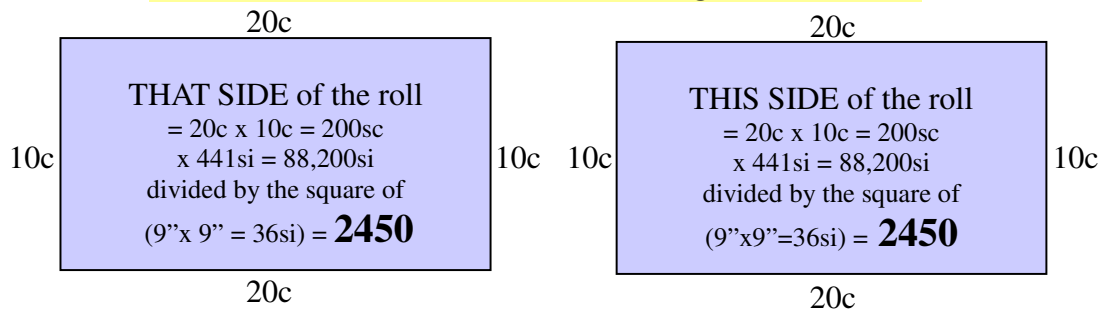

CALENDAR COINCIDENCES

(or one of PALMONI's secrets?)

This calendar is set to a 30-day prophetic cycle.

Christ arose on the day after the Sabbath, numbered DAY ONE, which means that the previous day, the Sabbath, was number 30.

ACTS 1						
SUNDAY	MONDAY	TUESDAY	WEDNESDAY	THURSDAY	FRIDAY	SABBATH
1- Resurrection	2	3	4	5	6	7
8	9	10	11	12	13	14
15	16	17	18	19	20	21
22	23	24	25	26	27	28
29	30	(31)1	(32) 2	(33)3	(34)4	(35)5

(36)6	(37)7	(38)8	(39)9	(40) 10 Ascension Acts 1:9-11	(41)11	(42)12
(43)13	(44)14	(45)15	(46)16	(47)17	(48)18	(49)19
(50) 20 Pentecost	(51)21	(52)22	(53)23	(54)24	(55)25	(56)26
(57)27	(58)28	(59)29	(60)30	(61)1	(62)2	(63)3
(64)4	(65)5	(66)6	(67)7	(68)8	(69)9	(70)10

1. Sabbath is associated with the numbers 7, 14, 21, 28.
2. Jesus ascended on the 40th day - day number **10 & 40**.
3. He descended as the **Angel of Revelation 10**, and in 1840.
4. He ascended on the 40th day - Acts 1: **9-11**.
5. He descended as the **Angel of Revelation 18** on 9/11.
(same as the Angel of Revelation 10)
6. Notice the number 70 (10) falls on the Sabbath:
70 years captivity = **10 x 2520**.

IS KNOWLEDGE OF THE 2520 IMPORTANT FOR SALVATION FOR SEVENTH-DAY ADVENTISTS?

-YES!

NOTE:

The words of Leviticus 25 & 26 were *spoken by God* to Moses.

Exodus 5:2 "And Pharaoh said, Who is the LORD, that I should *obey his voice* ..."

"I AM that I AM" gave us the 2520 *with His Voice*

While in the Temple on the Sabbath day, Jesus spoke these words to the Jews:

"Had ye believed Moses, ye would have believed me: for he wrote of me.

But if you believe not his writings, how shall ye believe my words?"

John 5:46, 47

2 Timothy 3:16

All scripture is given by inspiration of God, and is profitable for

doctrine, for reproof, for correction, for instruction in righteousness:

ALL SCRIPTURE?

"All scripture" includes the "seven times" or the 2520 of Lev. 25 & 26, including the additional evidences given in the detailed measurements of the Temples in Exodus, Ezekiel, Kings and Chronicles.

When I visit your home, do I need to know the detailed measurements of your house plan?
No, not unless I want to build a house exactly like yours.
Why then did God give us the measures of His three homes?

Answer:

**We need to build a character just like His.
His character is represented by the
measurements in His Temples. Those measures
symbolize the Law of God, the Ten Commandments.**

"Ye shall be holy." This is the keynote of the book of Leviticus.
Throughout the book stress is ever on holiness." 1BC 788

Holiness is what the 2520 is all about!

It is also a warning to stay away from spiritualism and idolatry.

NOTES



QUESTIONS ABOUT THE 2520 BY A RETIRED SDA PROFESSOR, AND ANSWERS

HIS QUESTION

THE ANSWER

<p>1. If this is to be called a prophecy, then what prophet spoke it?</p>	<p>1. God spoke it to Moses (Lev. 26). Hosea 1:4-5; Isa. 7:8; Isa. 10:11. Hosea declares that Ephraim and Israel shall fall, and that Judah also shall fall with them; Isaiah represents the king of Assyria as threatening to do to Jerusalem as he had done to Samaria; ...The prophecy of Isa 7:8, is correctly dated B. C. 742; 65 years from that point bring us to B. C. 677. In that year was the final breaking of Ephraim, that it should not be a people. (2 Kings 17). Having performed this work, which necessarily occupied some months, they were then ready to invade Judah in 677. ...From that time 2520 years reach to the autumn of A. D. 1844. From <i>THE TRUE MIDNIGHT CRY</i>, AUG. 22, 1844</p>
<p>2. What event did he start with?</p>	<p>2. The removal of Kings Hoshea (723 B.C.) and Manasseh (677 B.C). Dan. 2:21 – “ he [God] removeth kings, and setteth up kings: ...”</p>
<p>3. What <u>event</u> did he say would occur at the <u>end</u>?</p>	<p>3. 723 B.C. -1798 – Dan. 8:19 – “last end of the indignation.” 677 B.C. -1844 – Eze. 21:27 – until he come whose right it is; and I will give it him.</p>
<p>4. Is this a prophecy or simply a mathematical extrapolation?</p>	<p>4. The 2520 is a threatened <u>curse</u> for idolatry that would last 2520 yrs. Matthew Henry's Commentary says these are “prophecies”, “He that foresaw all their</p>

	<p>rebellions, knew they would prove so.” Lev. 26:19. E.G. White: YI, 4/23/1903 “these are some of the <u>prophecies</u>”; Great Controversy, p. 32: “the warning <u>prophecy</u> given fourteen centuries before...” Galileo: “<u>Mathematics</u> is the language with which God has written the universe.” Plato: “Geometry existed before creation.”</p>
<p>5. The 2520 “chart” is of non-Adventist origin and without Spirit of Prophecy approval: The designer was Charles Fitch, who never kept the Sabbath and is related only by Millerite affiliation.</p>	<p>5. a. “ ... the <u>Spirit of God</u> had moved upon Charles Fitch to devise the prophetic chart ...” <i>Spirit of Prophecy</i>, p. 241-242. b. Fitch laid in his grave before Sabbath truth known, and later seen to be in heaven in a vision of EGW. c. God & SOP must have approved of Charles Fitch.</p> <p><i>“The Lord showed me</i> that the 1843 chart was directed by his hand, and that no part of it should be altered; that the figures were <i>as he wanted them</i>. That his hand was over and hid a [singular] mistake [1843] in some of the figures [several 1843s on the chart], so that none could see it, until his hand was removed.” RH, 11/1/1850</p>
<p>6. E.G. White calls the 2300 DAY PROPHECY of Dan 8:14 the “longest and last” Bible prophecy. GC 351. It undermines the SOP to say the 2520 is the longest prophecy.</p>	<p>6. Lets re-read that statement: “The time is fulfilled, the kingdom of God is at hand,” so Miller and his associates proclaimed that the longest [2520] and last prophetic period brought to view in the Bible was about to expire, that the judgment was at hand, and the everlasting kingdom was to be ushered in. The preaching of the disciples in regard to time was based on the <u>seventy weeks of Daniel 9</u>. The message given by Miller and his associates announced the termination of the 2300 days of Daniel 8:14, of which the seventy weeks <u>form a part</u>. The preaching OF EACH [the 490 & 2300] was based upon <u>the fulfillment of a different portion</u> of the same great prophetic period [2520].” {GC 351.1}</p> <p style="text-align: center;">OF EACH:</p> <p>The “each” can pertain to the dates <u>or</u> the children of Israel and the Millerites in respect to the 70 weeks and the 2300 years. Hence the conclusion can only be that it was a different period since the 2300 years cannot be part of itself.</p>
<p>7. She [E.G.White] never endorsed or promoted the 2520 timespan in the Spirit of Prophecy writings.</p>	<p>7. The 2520 was an established truth for her. “All the messages given from 1840–1844 [all are included on the 1843 chart, including the 2520] are to be made forcible now, for there are many people who have lost their bearings.” 21MR 437. She does indirectly endorse in GC p. 32 when she refers to the recap of the “prophecies” given by Moses in Deut. 28. (See below*) She also wrote, “Not a peg or pin is to be removed” (2SM 104) from the messages of the three angels. The 2520 was included in those messages. 300 Millerite preachers preached the 2520 <u>accompanied by the angel of Rev. 10</u> (our Lord), and EGW repeatedly endorsed that message. The issue against the 2520 boils down to the <u>words of the prophet</u>. Is she, or is she not - a prophet? The three Angel’s messages are to be repeated, accompanied by Jesus, the Angel of Rev. 18. Since the 2520 was part of those messages, therefore the Angel of Revelation 18 accompanies the revival & present truth warning message of the 2520. <u>In 1905, 61 years after 1844, E.G. White wrote: “We have, as had John, a message to bear of the things which we have seen and heard. God is <u>not giving us a new message</u>. We are to proclaim <u>the message that in 1843 and 1844</u> brought us out of the other churches. ...” The 2520 was part of that message.</u> “... <u>the Lord gave me a vision</u> and showed me that the truth must be made plain upon tables [the new 1850 chart], and it would cause many to decide for the truth by the third angel’s message <u>with</u> the two former being made plain upon tables.” 5MR 202-203</p>
<p>8. Since the organization of the SDA church the “2520” has never been part of our theology!</p>	<p>8. The words of the Prophet spoken from 1903 to 1907 state clearly that the messages given from 1840 - 44 are the same messages that we are to give today. That includes 677, 457, 508, 538, 1798, 1844, the “daily” and more.</p>
<p>9. Number 2520 isn’t written anywhere in the Bible.</p>	<p>9. Neither is 677, 457, 538, 1798 or 1844. You have to figure it out. Same with the 2520. He is the one who put the DETAILED measures in the Temples adding up to 2520. He put the 2520 measures in cubits, inches, feet and sq. feet. How about Leviticus 25? Every 49 years there would be 2520 days the land rested, (do the math). Also, if time, times and half a time = 1260, then “seven times” = 2520. There is much more.</p>
<p>10. The first of two 2520 time spans</p>	<p>10. <u>The 2520 begins and ends with the setting up or putting down of a king</u> (Dan.2:21).</p>

<p>begin with 723 B.C., but the SDA Commentary p. 947 gives 722 B.C. as the appropriate defeat of Israel (Samaria) by the Assyrians. That throws off the 2520 time dating to 722 B.C. – 1799, not 1798.</p>	<p>“The calendars for reckoning the years of kings in Judah and Israel were offset by six months, that of Judah starting in Tishri (in the fall) and that of Israel in Nisan (in the spring). Cross-synchronizations between the two kingdoms therefore often allow narrowing of the beginning and/or ending dates of a king to within a six-month range. In the case of Hoshea, synchronization with the reign of Hezekiah of Judah shows that he came to the throne some time between Tishri 1 of 732 B.C. and the day before the first of Nisan, 731 B.C. The end of his reign occurred between the first of Nisan, 723 B.C., and the day before Tishri 1 of the same year. This narrowing of the dates for Hoshea is supplied by later scholars who built on <u>Thiele's</u> work, because <u>Thiele</u> did not accept the Hoshea/Hezekiah synchronisms of 2 Kings 18. That Hoshea died before Tishri 1 in the fall of 723 B.C. is additional evidence that it was Shalmaneser V, not Sargon II, who initially captured Samaria. Shalmaneser did not die until December 722 or January 721 B.C.” Source is Wikipedia: <i>Hoshea</i>. PS: Thiele was a well respected SDA.</p>
<p>11. The second time span depiction of the 2520 is taken from the “fall of Judah” (the southern kingdom) & presumes that date to be from 677 B.C. but:</p> <p>a. The captivity of Judah began 605 B.C., b. for 70 years until 536 B.C. = 70 years captivity (Jer. 25:11-12; 29:10). Plus, c. Manasseh had repented and the kingdom had been restored.</p>	<p>11. The 2520 loss of national sovereignty is defined by the <i>fall of a king</i> in 677 B.C. (see #2 & #10). Judah became subjects of Assyria (later Babylon) when Manasseh was taken prisoner and released. He was not the boss anymore! From that time forward they were subjects of foreign kings never to have their own sovereignty! (as Canada is subject to England) Judah’s 2520 continued in spite of Manasseh’s repentance. (2 Kings 24:3) a. 677 B.C. - Loss of national sovereignty (to Assyria). b. 607 B.C. - Jehoiakim is made 18th ruler of Judah by Pharaoh-Necho of Egypt. This is the first time a king of Judah has been hand-picked by a foreign king. (Read details in 4BC, p. 755.) From autumn of 607 to autumn of 537 is 70 yrs. The Jews began their return to their homeland in the Spring of 536 B.C. c. 605 B.C. - Daniel & three friends taken prisoner to Babylon. Dan. 1:1-2.</p> <p>Manasseh was an "earnest" down payment: (PK 382). Earnest: noun: money paid as a guarantee. Manasseh was the guarantee of the "seven times" curse.</p> <p>The 70 years literal captivity was a punishment within the 2520 years. It was to give the land it's “sabbath rests” which, not by accident, adds up to 10 x 2520 days.</p> <p>Lev. 26:35 "As long as it lieth desolate it shall rest; <i>because</i> it did not rest in your sabbaths <u>when ye dwelt upon it.</u> " The Jews had never obeyed this law. After their return from captivity, they began to be very legalistic about most of it (except the Jubilee part) so much so they eventually crucified Jesus.</p>
<p>12. Regarding the “seven times” of Dan. 4:15-16, there is no contextual foundation for going beyond a literal seven year span (no day-year).</p>	<p>12. Consider this: Ezek 4:6, “Again, when you have accomplished these, you shall lie on your right side, and shall bear the iniquity of the house of Judah: forty days, each day for a year, have I appointed it to you.” So for every "day" that Ezekiel was to lie on his side a full year would pass for Israel. Nebuchadnezzar also "lived out" a prophetic period of "7 times". This indicates that the "7 times" might also be calculated at "a day for a year" just like the prophecy that Ezekiel "lived out". (Even if this explanation is rejected the 2520 survives without Nebuchadnezzar's 2520.)</p>
<p>13. No proper Bible basis for a 2520 year “prophecy” in Lev. 26. (refers to repeated punishments – not a time span). “insubordination” would be punished seven-fold more.</p>	<p>13. A thorough word study of cardinal and ordinal numbers with the root words of “seven times” will support the literal 2520 years following grammatical rules. Moses knew what he was doing. Leviticus 25 starts with Moses on Mt. Sinai and ends in Lev 26 with Moses on Mt. Sinai. These two chapters are about the same topic. The focus is the Sabbath and it is established in the first 9 verses of Lev 25. The Pattern is established based on the day-for-a-year principle and is linked directly to the Sabbath Commandment of Ex. 20:8-11. The grammatical intent and directive is about the Sabbath and the day-for-a-year principle. Therefore the 2520 is the cornerstone for the sabbath-rest-for-the-land law, and the curse that accompanies the breaking of the Commandment of rest for the land. Num 14:34 “ After the number of the days in which ye searched the land, even forty days, each day for a year, shall ye bear your iniquities, even forty years, and ye shall know my breach of promise.”</p>
<p>14. SOP mentions Lev. 26 only four times without any prophetic significance</p>	<p>There are six times. Those four times are: 1. <i>Education</i>, p. 140;</p>

given to it.

2. *Patriarchs & Prophets*, p. 535;
 3. *Prophets and Kings*, p. 429;
 4. *Manuscript Releases*, Vol. 10, p. 190.
- There are also two more references to Lev. 26.
5. *The Youth's Instructor*, April, 23, 1903
 6. *The Spirit of Prophecy*, Vol. 2, pp. 54-55 (see below)

THE TWO NON-REFERENCED QUOTES

The Youth's Instructor, April 23, 1903
GOD'S PURPOSE CONCERNING ISRAEL:

Ellen White wrote two paragraphs in which she quoted from Deut. 12:28-32; Lev. 20:22-24; Leviticus 26:14-17; 31-33; 38,41,42, 44,45. Then, in the third paragraph she begins with these words: "These are **some of the prophecies** concerning Israel." The verses with the "seven times" were sandwiched in between the verses she quoted from Leviticus, and are "some of the prophecies."

The Spirit of Prophecy, Vol. 2, p. 54, 55
The setting of this quote is the time of John the Baptist.

Ellen White quotes from Leviticus 26:14-17 and then writes: "**The Jews were experiencing the fulfillment of the threatened curse of God for their departure from him, and for their iniquity;** ... John [the Baptist] declared to them that unless they bore fruit, they would be hewn down and cast into the fire."

John was a contemporary of Christ and this was over 700 years after the literal 70 years captivity.
The 490-year prophecy was not a "curse" it was a promise. This could only refer to the 2520.

*REFERENCE FOR QUESTION #7

Ellen White quotes from Deut. 28:56,57 which is just a recap of the prophecy of Leviticus 26. Leviticus 26 was given at the beginning of the Exodus, and Deut. 28 was given at the end of the Exodus.

<p>Leviticus 26 PROPHECY AT THE BEGINNING OF THE EXODUS</p>	<p>Deuteronomy 28 RECAP-PROPHECY GIVEN AT THE END OF THE 40 YEARS</p>
<p>Verses 4 - 13: Emphasizes the blessings of the covenant.</p> <p>6:14: But if ye will not hearken unto me, ...</p> <p>14 - 43: Moses tells of the curses for disobedience.</p>	<p>Verses 3 -14: Emphasizes the blessings of the covenant.</p> <p>28:15: But it shall come to pass, if thou wilt not hearken ...</p> <p>16-68: Moses tells of the curses for disobedience.</p>

Luke 16:31, And he said unto him, If they hear not Moses and the prophets, neither will they be persuaded, though one rose from the dead.

SHALL WE REPEAT THE HISTORY OF THE JEWS IN OUR WORK?

"... Our young men look to our older brethren, and as they see that they do not accept the message, but treat it as though it were of no consequence, it influences those who are ignorant of the Scriptures to reject the light. **These men who refuse to receive truth, interpose themselves between the people and the light.** But there is no excuse for any one's refusing the light, for it has been plainly revealed. There is no need of any one's being in ignorance. We must clear the King's highway; for God will remove hindrances out of the way. God calls you to come up to his help against the mighty. Instead of pressing your weight against the chariot of truth that is being pulled up an inclined road, you should work with all the energy you can summon to push it on. **Shall we repeat the history of the Jews in our work? The leaders of the people in the time of Christ brought all their power to bear against the work of Christ, that his way might be hedged up. The people must go to God for themselves**, and pray that all wrong impressions may be removed from their hearts,--pray that the word of God *may not be clouded by men's interpretations.*" {RH, March 18, 1890 par. 5}

"Once to Every Man and Nation"

SDA Hymnal #606

Verse 1, first part:

"Once to every man and nation, Comes the moment to decide,
In the strife of truth with falsehood, For the good or evil side;"

Verse 2, second part:

"New occasions teach new duties, Time makes ancient good uncouth
"They must upward still and onward, Who would keep abreast of truth."

CHAPTER 13

**The "Seven Times",
the 2520 Lambs,
the Flour - the Oil - the Wine,
and the "Daily Sacrifice"
are all Warnings to Laodicea!**

Hebrews 9:11-12

But Christ ...Neither by the blood of goats and calves, but **by his own blood he**

entered in once into the holy place, having obtained eternal redemption for us.

Ephesians 1:7

In whom we have redemption **through his blood**, the *forgiveness of sins*, according to the riches of his grace;

"The mystery of the cross explains all other mysteries."

4SOP 469

"The Sacrifice of Christ as an atonement for sin is the great truth around which all other truths cluster. In order to be rightly understood and appreciated, *every truth* in the Word of God, from Genesis to Revelation, must be studied in the light that streams from the cross of Calvary. I present before you the great, grand monument of mercy and regeneration, salvation and redemption,--the Son of God uplifted on the cross. This is to be the foundation of every discourse given by our ministers." Gospel Workers 315

ATONEMENT FOR SIN

(All emphases by the author.)

"The spotless Son of God hung upon the cross, His flesh lacerated with stripes; those hands so often reached out in blessing, nailed to the wooden bars; those feet so tireless on ministries of love, spiked to the tree; that royal head pierced by the crown of thorns; those quivering lips shaped to the cry of woe. And all that He endured--the blood drops that flowed from His head, His hands, His feet, the agony that racked His frame, and the unutterable anguish that filled His soul at the hiding of His Father's face--speaks to each child of humanity, declaring, It is for thee that the Son of God consents to bear this burden of guilt; for thee He spoils the domain of death, and opens the gates of Paradise. He who stilled the angry waves and walked the foam-capped billows, who made devils tremble and disease flee, who opened blind eyes and called forth the dead to life,--offers Himself upon the cross as a sacrifice, and this from love to thee. **He, the Sin Bearer, endures the wrath of divine justice**, and for *thy sake becomes sin itself*." (DA 755)

In the closing days of this earth's history God has a special message of encouragement to the wise virgins, and a warning to the foolish. The 2520 or "seven times" is a message saying that **right now** is the time to make sure our sins are *forsaken*¹ and sent up to Jesus in the Most Holy, so that when He stands up as "Michael", **His Blood will have been already sprinkled "seven times" on our behalf and our sins have been permanently blotted out.**

Why did the "seven times" of Leviticus 26 stop being a "conditional" curse and become a "prophecy"? In gathering information to find the answer to that question it was seen that the blood of a bullock and the blood of a goat were **both sprinkled "seven times" in the Most Holy on the Day of Atonement** (Leviticus 16:11-16). At other times the blood of a bullock was also sprinkled "seven times" **before the veil** in the Holy: "If the priest that is anointed do sin ("thus bringing guilt upon the people")² then "the priest shall dip his finger in the blood, and sprinkle of the blood **seven times** before the LORD, **before the veil** of the sanctuary" (Lev. 4:3-6). This is also repeated for when the "whole congregation" sinned" (Lev. 4:13-17).

This is what happened when Jesus ascended to heaven, He symbolically sprinkled His Blood **before the Veil** in the first apartment "seven times", **but not for Judah**. On the anti-typical Day of Atonement His Blood was also sprinkled **two times seven times** (2 x 2520) in the Most Holy, **but not for the churches that rejected** the first and second angel's messages. Satan became their leader (GC 28; DA 738) just as he became the leader of Judah in 31 A.D. when they chose Barabbas instead of Jesus.

1 Websters: forsake - v. to leave behind; forsaken - adj. abandoned/deserted. Proverbs 28:13 - He that covereth his sins shall not prosper:

but whoso **confesseth** and **forsaketh** them shall have mercy. "If those who hide and excuse their faults could see how Satan exults over them, how he taunts Christ and holy angels with their course, they would make haste to confess their sins and **to put them away**. Through defects in the character, Satan works to gain control of the whole mind, and he knows that if these defects are cherished, he will succeed. Therefore he is constantly seeking **to deceive** the followers of Christ with his fatal sophistry that **it is impossible** for them to overcome." The Great Controversy between Christ & Satan, p. 489.

2 This is the RSV translation, KJV reads: "according to the sin of the people".

"**Sprinkle of the blood.** As there was no one higher in rank than the high priest, who could officiate for him, he ministered the blood himself. ...the priest did not sprinkle the blood on the veil, but before it. It is also of interest that he used only one finger³ in sprinkling. Furthermore, this sprinkling was done only when the **anointed priest** or the **whole congregation sinned**. ...True, there were other national apostasies, but as the offering was only to be brought when they repented of their sins, there could not have been many instances."

Matthew Henry's Commentary (non-SDA) on Leviticus 4:13-21 is very interesting, for those who understand the "seven times" history of the two kingdoms:

"When a sacrifice was to be offered **for the whole congregation**, the elders were to lay their hands upon the head of it (**three of them at least**), as representatives of the people and agents for them. ..." The "blood of this sin-offering, as of the former, was to be sprinkled **seven times** before the Lord, v. 17. It was not to be poured out there, but sprinkled only; for the cleansing virtue of the blood of Christ was then and still is sufficiently signified and represented by sprinkling, Isaiah 52:15. It was to be sprinkled **seven times**. Seven is a number of perfection, because when God had made the world in six days he rested the seventh; so this signified the perfect satisfaction Christ made, and the complete cleansing of the souls of the faithful by it; see Hebrews 10:14. ...When the offering is completed, it is said, atonement is made, and the sin shall be forgiven, v. 20. The promise of remission is founded upon the atonement. **It is spoken here of the forgiveness of the sin of the whole congregation, that is, the turning away of those national judgments which the sin deserved.**"

The first part of this document will set forth the reasons why the conditional curses of Leviticus 26 became a prophecy. The last pages will show you that the 2520 is a ray of light streaming from the cross of Calvary. I do not address all the symbolism, just present the facts, letting you connect the dots.
LJN (the.2520@gmail.com)

The World to Be Warned

Review and Herald, July 28, 1904

"... Are we to wait until the fulfillment of the prophecies of the end before we say anything concerning them? Of what value will our words be then? Shall we wait until the judgments fall upon the transgressor before we tell him how to avoid them? ... Study carefully the following scriptures" (Isaiah 2:17-19 and Joel chapter 2). And they shall go into the holes of the rocks, and into the caves of the earth, for fear of the Lord, and for the glory of his majesty, **when he ariseth to shake terribly the earth** (after probation closes)⁴. Blow ye the trumpet in Zion, and sound an alarm in my holy mountain: let all the inhabitants of the land tremble: for the day of the Lord cometh, for it is nigh at hand.

Therefore also now, saith the Lord, turn ye even to me with all your heart, and with fasting, and with weeping, and with mourning; and rend your hearts, and not your garments, and turn unto the Lord your God: for he is gracious and merciful, slow to anger, and of great kindness, and repenteth him of the evil. Who knoweth if he will turn and repent, and leave a **blessing** [Lev. 26] behind him; even a **meat offering** [126] and a **drink offering** [1260] unto the Lord your God?

"The Lord has declared the judgments and calamities that must fall upon those who continue to dishonor him. Warnings have been given by God, and **these warnings should be kept before the people**. God's appointed messengers are to give the call to flee from the wrath to come."

"Blow the trumpet in Zion, sanctify a fast, call a solemn assembly: gather the people, sanctify the congregation, assemble the elders, gather the children: ...let the bridegroom go forth of his chamber, and the bride out of her closet. Let the priests, the ministers of the Lord, weep between the porch and the altar, and let them say, Spare thy people, O Lord, and give not thine heritage to reproach, that the heathen should rule over them: wherefore should they say among the people, Where is their God?"

"Then will the Lord be jealous for his land, and pity his people. Yea, the Lord will answer and say unto his people, Behold, **I will send you corn** (flour-126), and **wine** (1260), and **oil** (1260), and ye shall be satisfied therewith: and I will no more make you a reproach among the heathen."

"Fear not, O land; be glad and rejoice: for the Lord will do great things. Be not afraid, ye beasts of the field: for the pastures of the wilderness do spring, for the tree beareth her fruit, the fig-tree and the vine do yield their strength. Be glad then, ye children of Zion, and rejoice in the Lord your God: for he hath given you the former rain moderately, and he will cause to come down for you the rain, the former rain, and the latter rain in the first month. And the floors shall be full of **wheat** (126), and the fats shall overflow with **wine and oil** (2520 blessings). ..."

The warnings we are to keep "before the people" are in the same context as the meat (meal) and drink offerings, the time when He will arise to "shake terribly the earth"⁷ and the "latter rain".

3 Finger
4 See nu

What is significant about the meat and drink offerings of corn, oil and wine? Those offerings have the numbers of 2520, 1260 and 126 in their measures of Flour (corn), Oil and Wine.

"That **Lamb** whose wrath (the curses of Lev. 26) will be so terrible to the scorners of His grace will be grace and righteousness and love and blessing (the blessings of Lev. 26) to all who have received Him." {TMK 356}

There were 2520 Lambs that could have been a blessing to Judah, but instead became a curse.

"**Repent** ye therefore, and be converted, **that your sins may be blotted out**, when the times of refreshing shall come from the presence of the Lord; and he shall send Jesus." (Acts 3:19, 20)

The sins of Judah were not "blotted out".

"Christ was the foundation of the Jewish economy. The **whole system of types and symbols** was a **compacted prophecy** of the gospel, a presentation in which were bound up the promises of redemption. {AA 14.1}

"So far as it was of divine institution, the **entire system of Judaism** was a **compacted prophecy** of the gospel." {DA 211.5}

On the following pages "eye-salve" will help you understand that a part of the "compacted prophecy" which was fulfilled to literal Israel, was the "seven times" (2520), and that the message of the "seven times" (2520) is now being given as a warning to modern Israel ⁵.

The "seven times" (2520) message that has come to our attention since 9/11 is telling us that the time has come for the last acts in the great controversy between Christ and Satan to be fulfilled, and the door of mercy is about to shut for the third ⁶ and last time upon the five foolish virgins who have not brought their sins to the cross.

"In the time of the Anti-typical Day of Atonement the work we are to do is to bring our sins to the cross. All of what the prophets have spoken of is designed to prepare us to submit and become fully obedient to God so that He can do His mighty work in us to prepare us to finish the work, to bring us, His children home. This is the Everlasting Gospel, Christ in you the Hope of Glory. The same gospel is spoken of in Revelation 14:6-12, and stated in Genesis 3:15 and in Genesis 2:16-17. The depth of this message is there for all to see, for those who wish to buy the eye-salve." RM, www.the2520yearprophecy.com

**THE "SEVEN TIMES" BLESSINGS & CURSES OF LEVITICUS 25 & 26
WERE A WARNING TO ANCIENT ISRAEL'S
(1) JUDGES; (2) KINGS; (3) PRIESTS & RULERS ⁷**

**THE 2520 "BLESSINGS OR CURSES" OF LEVITICUS 26 IS NOW
A FOURTH WARNING TO THE CHURCH OF LAODICEA ⁸**

"I was pointed back to ancient Israel. But two of the adults of the vast army that left Egypt entered the land of Canaan. Their dead bodies were strewn in the wilderness because of their transgressions. **Modern Israel are in greater**

⁶ The first time: the nation of Judah at the Cross; the second time: 1844 (the churches that refused the first two Angel's messages); the third time: the church of Laodicea, "So then because thou art lukewarm, and neither cold nor hot, I will spue thee out of my mouth."

⁷ This includes the Sanhedrin, the scribes (the Bible scholars), the Pharisees, the ministers (Levites) etc.

⁸ To continue the type/anti-type symbol, the warning would be to the General Conference of Seventh-day Adventists.

danger of forgetting God and being led into idolatry than were His ancient people. Many idols are worshiped, even by professed Sabbathkeepers. God especially charged His ancient people to guard against idolatry, for if they should be led away from serving the living God, His curse would rest upon them, while if they would love Him with all their heart, with all their soul, and with all their might, He would abundantly bless them in basket and in store, and would remove sickness from the midst of them."

"**A blessing or a curse is now before the people of God** - a blessing if they come out from the world and are separate, and walk in the path of humble obedience; and a curse if they unite⁹ with the idolatrous, who trample upon the high claims of heaven. The sins and iniquities of rebellious Israel are recorded and the picture presented before us as a warning that if we imitate their example of transgression and depart from God we shall fall as surely as did they. "Now all these things happened unto them for ensamples: and they are written for our admonition, upon whom the ends of the world are come." (1T 609)

The 2520 "seven times" curse separated ancient Israel from God, and it will also separate Laodicea from God.

THE 2520 IN THE LIGHT OF THE CROSS

Because some prominent leaders oppose the message of the 2520, teaching others that the "seven times" is "not a prophecy" I have put together some quotes from the SOP as to what happened when the Blood of Jesus was shed at the Cross and why the conditional curses of Leviticus 26 became a literal prophecy of "seven times".

"HIS BLOOD BE UPON US"

For breaking the Covenant, choosing a new king and refusing His Blood, the "seven times" (sevenfold) conditional prophecy became a literal 2520 years (seven times) prophecy.

Ephesians 1:7 - In whom we have redemption **through his blood**, the forgiveness of sins, according to the riches of his grace;

"Mercy and forgiveness are the reward of all who come to Christ trusting in His merits to take away their sins. We are **cleansed from sin by the blood** of Christ Jesus our Saviour." Letter 216, 1906, p. 2.

Hebrews 12:24 - And to Jesus the mediator of the new covenant, and to the blood of sprinkling, that speaketh better things than that of Abel.

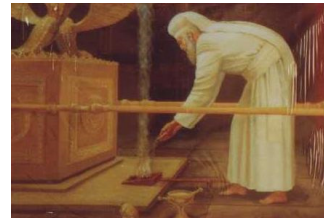

NO KING BUT CAESAR

John 19:15, (31 A.D.):

But they cried out, Away with him, away with him, crucify him. Pilate saith unto them, Shall I crucify your King? The chief priests answered, **We have no king but Caesar.**

E.G. White: The Youth's Instructor, Feb. 1, 1900:

"What was Christ's grief to see the Jews fixing their own destiny **beyond redemption!** He alone could comprehend the significance of their rejection, betrayal, and condemnation of the Son of God. **His last hope** for the Jewish nation was gone. **Nothing could avert her doom.** By the representatives of the nation God was denied as their ruler. By worlds unfallen, by the whole heavenly universe, the blasphemous utterance was heard, '**We have no king but Caesar.**' **The God of heaven heard their choice.** He had given them opportunity to repent, and they would not."

Matt. 27:24-25:

"When Pilate saw that he could prevail nothing, but that rather a tumult was made, he took water, and washed his hands before the multitude, saying, I am innocent of the blood of this just person: see ye to it. *Then answered* all the people, and said, **His blood be on us, and on our children.**"

FOUR TIMES

E.G. White: Desire of Ages, p 738 -739:

⁹ Spiritual Formation as a required course for our ministers is idolatry. Sending our ministers to Willow Creek is idolatry. These are just a couple examples of modern Israel's idolatry, equally as bad as the idolatry of what Manasseh and other kings did.

"When Pilate declared himself innocent of the blood of Christ, [1] **Caiaphas** answered defiantly, **'His blood be on us, and on our children.'** The awful words were taken up by the [2] **priests and rulers**, and [3] **echoed by the crowd** in an inhuman roar of voices. [4] **The whole multitude answered and said, 'His blood be on us, and on our children.'**

"The people of Israel had made their choice. Pointing to Jesus they had said, 'Not this man, but Barabbas.' Barabbas, the robber and murderer, was the representative of Satan. Christ was the representative of God. Christ had been rejected; Barabbas had been chosen. Barabbas they were to have...." Looking at Jesus, "the Jews had cried, 'His blood be on us, and on our children.' **That awful cry ascended to the throne of God. That sentence, pronounced upon themselves, was written in heaven. That prayer was heard.** The blood of the Son of God was upon their children and their children's children, a **perpetual**¹⁰ **curse.**"

E.G. White: Review and Herald, Feb. 19, 1914, par. 2 & 3:

"God's favor toward Israel had always been conditional on their obedience. *At the foot of Sinai*, the hosts of Israel had entered into covenant relation with God as his "peculiar treasure . . . above all people." Exodus 19:5. They were to be to him "a kingdom of priests, and an holy nation." Solemnly they had promised to follow in the path of obedience. [1] **"All that the Lord hath spoken we will do,"**[Ex.19:8] they said. And when, *a few days afterward*, God's law was spoken from Sinai, and additional instruction in the form of statutes and judgments was communicated through Moses, the Israelites *with one voice again promised*. [2] **"All the words which the Lord hath said will we do."** Exodus 24:3. At the ratification of the covenant, the people *once more united in declaring*, [3] **"All that the Lord hath said will we do, and be obedient."** Verse 7. God had chosen Israel as his people, and they had chosen him as their King. (par. 2) ... Near the close of the wilderness wandering¹¹ the [4] **conditions of the covenant were repeated.**" Ibid, par. 8

"Henceforth the Jewish nation, as a nation, was as a branch severed from the vine,--a dead, fruitless branch, to be gathered up and burned,--from land to land throughout the world, from century to century, dead,--dead in trespasses and sins,--**without a Saviour!** {YI, 2/1/1900}

E.G. White: Review and Herald, May 2, 1893 par. 8:

"... but as a nation, they rejected the counsel of God against themselves. When the judgment of God did fall upon the Jews, it was an evidence that they were finally impenitent, and set stubbornly against light and truth, against the messages and warnings of God. They pursued a course similar to that of their fathers, and had **filled up the measure of their iniquity**. They had worn out the divine patience by their repeated sins, and so great was their influence for evil upon the human family, that God made an example of them before the world."

"His blood be upon us and our children". Upon His ascension into the Holy Place, Jesus could not sprinkle His Blood "*seven times*" in behalf of Judah. Had Judah repented, the Blood of Jesus sprinkled "*seven times*" would have been a blessing, but when the blood was not sprinkled, and sins were not forgiven, it was a curse.
The nation of Judah had no Saviour! No Saviour, and no redemption.

THE BROKEN COVENANT

Psalms 105:9-11

"Which covenant he made with Abraham, and his oath unto Isaac; And confirmed the same unto Jacob for a law, and to Israel for an everlasting covenant: Saying, Unto thee will I give **the land of Canaan**, the lot of your inheritance:" "Israel had received the law directly from the mouth of God at Sinai; and its sacred precepts, written by His own hand, were still preserved in the ark. Now it had been again written where all could read it. All had the privilege of seeing for themselves the **conditions of the covenant under which they were to hold possession of Canaan**. All were to signify their acceptance of the terms of the covenant and give **their assent to the blessings or curses** for its observance or neglect. The law was not only written upon the memorial stones, but was read by Joshua himself in the hearing of all Israel. It had not been many weeks since Moses gave the whole book of Deuteronomy in discourses to the people, yet now Joshua **read the law again.**" (Read *Patriarchs and Prophets*, the chapter titled: The Blessings and the Cursings.)

Dan. 9:27 - And he shall **confirm** the covenant with many for **one week [2520 days]**:
Webster's: confirm: to make definite, to make sure. confirmed: make permanent.

The seven years of the 70th week (2520 days) of Daniel 9:27 was the **sealing time** for Judah¹² (as a nation). During those seven years, Judah confirmed, (made permanent) her iniquity, while Christ and the apostles confirmed (made permanent)

10 Perpetual: Webster's - "continuous without any end". This means that this curse could never be repented and erased on Judah "as a nation". She also wrote: "I saw... that it would take a long while to make a very few of the Jews believe even in the first advent of Christ, much more to believe in His second advent." (Mar 136)

11 Read *Prophets and Kings*, pp. 499-500 about the 4th time(?) the covenant was ratified between Mt. Ebal & Mt. Gerazim.

12 Throughout Matthew, Mark, Luke and John, it was the representatives of the nation, the "chief priests (Levites-**ministers**),

the covenant. "For centuries there had been a turning away from God. ...The people themselves had been loading the cloud of vengeance which unmingled with mercy was about to burst upon them...." (1888, 915.2). Rejecting the warning messages had hardened ¹³ Judah's hearts, until they finally claimed Caesar as their king, cried for the blood of Jesus to be put on their heads, and for Barabbas (Satan), to be freed. This **filled up their cup of iniquity**, and when Jesus was crucified, the "seven times" ceased to be a conditional prophecy. Without the blood of Jesus there was no repentance accepted (Matt. 25:12 - "I know you not"). The Jewish priests and rulers, and the nation, was left without a Saviour. The door had shut on them and the Leviticus 26 "seven times" ceased to be conditional and became a time prophecy. There were no more promises of restoration, and since the "land" had been guaranteed to them on the condition of their obedience, they were removed from the land. The prophecy of Deuteronomy¹⁴ was fulfilled:

Deuteronomy 28:45

Moreover all these curses shall come upon thee, and shall pursue thee, and overtake thee, till thou be destroyed;

In November of 2012, the Prime Minister of Israel, Benjamin Netanyahu, spoke these words: "No United Nations decision can break the bond between the people of Israel and the land."

A SHUT DOOR

E.G. White: The Great Controversy, p. 430:

"... The Jews had refused to seek him in the only way whereby he could then be found, through the ministration in the sanctuary in Heaven. Therefore they found no communion with God. **To them the door was shut**. They had no knowledge of Christ as the true sacrifice and the only mediator before God; hence they could not receive the benefits of his mediation."

E.G. White, RH, April 18, 1893:

"Clouds of wrath were gathering over the doomed city; for **they called down upon themselves judgment** ¹⁵, crying, **His blood be on us and upon our children.**' That blood by virtue of which the repentant sinner might be forgiven--that blood by which a guilty world might be saved, by which the Jewish nation might be saved and purified, which was paid a ransom for the sins of the world, was to them **the final guilt in the cup of their iniquity.**"

"When Christ should hang on Calvary's cross, Israel's day as a nation favored and blessed of God would be ended." (4SOP 20)

TRADITION THEN

Every year for fourteen centuries, (except the years in Babylon), on the Day of Atonement the "whole congregation" gathered around the Sanctuary ¹⁶ or Temple while the priest brought the Blood of the bullock and sprinkled it "seven times" on the Mercy Seat. But, after hundreds of years the traditions of men seeped in and Judah forgot **the spiritual significance of the Blood that was to be sprinkled**. Their minds had been clouded by traditions and fables. They had blindly trusted their leaders and "as a nation" had an attitude of superiority, knowing they were God's special people. Their ship would always go through.

"Those Jewish teachers spoke in monotonous tones, and the plainest and most precious scriptures were made uninteresting and unintelligible, buried under such a mass of tradition and learned lore that after the Rabbis had spoken, the people knew less of the meaning of the Scriptures than before they listened." {CE 142.2}

"When Christ came to this earth the Jewish people had wholly lost sight of the meaning of the priesthood, and of the sacrifices. ... the meaning of these offerings they never understood. . . . **their tradition** was mixed with the truth and a jumbling confusion resulted. ... 'understanding neither what they say, nor whereof they affirm.'" (1 Timothy 1:5-7). F.C. Gilbert, *Practical Lessons*, 224.

scribes (Bible **scholars**) and **Elders** (Sanhedrin) who came against Christ and stirred up the people. The 70 Elders in Moses day aided in governing. When the "whole nation" sinned, it was the **Elders** who were to represent it in making atonement (Lev 4:13-15). Each city had its group of Elders. The Elders in Strong's NT4245 are suggested to be the Sanhedrin. E.G. White wrote that the Sanhedrin was the "supreme court" of the nation, and even though subordinated to Rome, had strong influence. DA 133. The Sanhedrin was responsible for the stoning of Stephen. Read Acts of the Apostles, the chapter titled: "The First Christian Martyr" starting on page 97.

13 Exodus 7:13 - Just as Pharaoh's heart was hardened when he refused to accept the messages of God sent through Moses.

15 **...a "seven times" judgment.**

16 "The people anxiously waited to hear the bells on the high priest's robe on the Day of Atonement. He had gone into the holiest in the white garments to sprinkle the blood and thus symbolically remove forever the record of their life's sins. ..." When the people heard the sound of the bells, their joy and thankfulness were profound." 4BC, p.776 (1978 version)

TRADITION NOW

(Higher Criticism)

Type the words: "higher education" into the EGW CD. There are **360** hits.

It is **TIME** to put away the "higher criticism" of the Bible Scholars!

Colossians 2:1, 8. For I would that ye knew what great conflict I have for you, and *for them at Laodicea*, and for as many as have not seen my face in the flesh; ... 2:8 Beware lest any man spoil you through philosophy and vain deceit, after the *tradition of men*, after the rudiments of the world, and not after Christ.

"Biblical criticism, defined as the treatment of Biblical texts as natural **rather than supernatural** artifacts, grew out of the rationalism of the 17th and 18th centuries. In the 19th century it was divided between the **higher criticism**, the study of the composition and history of biblical texts, and **lower criticism**, the close examination of the text to establish their original or "correct" readings. These terms are largely no longer used, and contemporary criticism has seen the rise of new perspectives which draw on literary and multidisciplinary sociological approaches to address the meaning(s) of texts and the wider world in which they were conceived." http://en.wikipedia.org/wiki/Biblical_criticism

Higher Criticism or the Historical-Critical Method is a tradition and a rudiment of man.
The proof-text method of study is God's plan. William Miller was guided by angels sent from God.

These angels guided his mind with the proof-text method of study.

The Holy Spirit will help you understand what He inspired the Bible writers to write.

THE FINGER OF GOD SYMBOLIZES THE HOLY SPIRIT

"This seven-fold ¹⁸ blood-tossing called attention to the thoroughness and completeness of the Saviour's atonement (AA 585), **while the priest's "finger" represented the role of the Holy Spirit in the atonement** (compare Matt 12:28 with Luke 11:20 to identify "finger" with the "Spirit"). On Sinai, God's Finger inscribed the words of the Decalogue on two stone tablets, and, almost a millennium later, wrote the doom of Babylon on the wall of Belshazzar's banquet hall. ..." Heb. 9:14)." Leslie Hardinge Ph.D., *With Jesus in His Sanctuary*, 496.

"The **Holy Spirit** traced these truths upon my heart and mind as indelibly as the law was traced by **the finger of God** upon the tables of stone, which are now in the ark, to be brought forth in that great day when sentence will be pronounced against every evil, seducing science produced by the father of lies." (Colporteur Ministry, p. **126**.)

Leviticus 4:6; 17 (For when the priest or whole congregation sins.) And the priest shall dip his finger in the blood, and sprinkle of the blood seven times before the LORD, before the veil of the sanctuary.	Leviticus 16:14; 19 (Day of Atonement) The Blood of a Bullock & Ram is each sprinkled "seven times". And he shall sprinkle of the blood upon it [Mercy Seat] with his finger seven times , and cleanse it, and hallow it from the uncleanness of the children of Israel.
---	--

The "finger of God" and Belshazzar:

"In the same hour came forth **fingers** of a man's hand, and wrote over against the candlestick upon the plaster of the wall of the king's palace:..." (Daniel 5:5) The words written were "mene, mene, tekel, upharsin". (The monetary value of those words was 2520 gerahs or 126 shekels). Belshazzar had sinned against the Holy Ghost just as centuries later, Judah as a nation would sin against the Holy Ghost.

The "finger of God" and "the Blood":

When Judah demanded for the blood of Jesus to be upon their own heads, Jesus could not plead His Blood on their behalf. His Blood was not sprinkled by the High Priest's **finger** "seven times" before the Veil. This was a sin against the "Holy Ghost" an "unpardonable sin". "Wherefore I say unto you, All manner of sin and blasphemy shall be forgiven unto men: but the blasphemy against the Holy Ghost **shall not be forgiven** unto men. And whosoever speaketh a word against the Son of man, it shall be forgiven him: but whosoever speaketh against the Holy Ghost, it shall not be forgiven him, neither in this world, neither in the world to come." Matthew 12:31-32.

The "finger of God" and "seven other spirits":

The "finger" [Holy Spirit] of God casts our devils, but, "if Christ does not dwell in the heart, the evil spirit returns... with "seven other spirits more wicked than himself, ..." {DA 323.3}

¹⁸ Hardinge also uses the "seven-fold" instead of "seven times". This is a common mindset (understanding only the conditional part of the "seven times"), but light is now shining from the cross on the prophecy of the "seven times".

Luke 11:20; 23-26:

...**But if I** with **the finger of God** cast out devils, no doubt the kingdom of God is come upon you. ... He that is not with me is against me: and he that **gathereth not with me scattereth**. When the unclean spirit is gone out of a man, he walketh through dry places, seeking rest; and finding none, he saith, I will return unto my house whence I came out. And when he cometh, he findeth it swept and garnished. Then goeth he, and taketh to him **seven other spirits more wicked** than himself; and they enter in, and dwell there: and the last state of that man is worse than the first."

When Judah chose Satan, their spiritual condition became much worse then it had been in the previous centuries. "God withdrew His protection from them and removed His restraining power from Satan and his angels, and the nation was left to the control of the leader she had chosen. Her children had spurned the grace of Christ, which would have enabled them to **subdue their evil impulses**, and now these became the conquerors. **Satan** aroused the fiercest and most debased passions of the soul. Men did not reason; they were beyond reason--controlled by impulse and blind rage. They **became satanic in their cruelty**. ...Satan was at the head of the nation, and the highest civil and religious authorities were under his sway." {GC 28.1} This history will be repeated when those who choose the "mark of the beast" are "cut off" by God and left to the control of Satan.

The magicians recognized the "finger of God".

Exodus 8:19 - The Holy Spirit's warnings rejected:

Then the magicians said unto Pharaoh, **This is the finger of God:** and Pharaoh's heart was hardened, and he hearkened not unto them; as the LORD had said.

The Ten Commandments and the "finger of God":

Exodus 31:18 - The Ten Commandments is the character of God the Father, God the Son, and God the Holy Ghost:

And he gave unto Moses, when he had made an end of communing with him upon mount Sinai, two tables of testimony, tables of stone, **written with the finger of God.**

THE "FINGER OF GOD" SPRINKLES HIS BLOOD "SEVEN TIMES"

This "seven times" is to remind us of the warnings of Lev. 26. When God says, "Thou shalt not," He in love warns us of the consequence of disobedience, in order to save us from harm and loss. (CG 223)

"Real sorrow for sin is the result of the working of the Holy Spirit. The Spirit reveals the ingratitude of the heart that has slighted and grieved the Saviour, and brings us in contrition to the foot of the cross. By every sin Jesus is wounded afresh; and as we look upon Him whom we have pierced, we mourn for the sins that have brought anguish upon Him. Such mourning will lead to the renunciation of sin." {DA 300.3}

John 8:6-9 This they said, tempting him, that they might have to accuse him. But Jesus stooped down, and **with his finger** wrote on the ground, as though he heard them not. So when they continued asking him, he lifted up himself, and said unto them, He that is without sin among you, let him first cast a stone at her. And again he stooped down, and wrote on the ground. And they which heard it, **being convicted by their own conscience**, went out one by one, beginning at the eldest, even unto the last: and Jesus was left alone, and the woman standing in the midst.

THE "FINGER OF GOD" IS ON THE "HAND OF GOD"

"The people heard with trembling. The convicting Spirit of God spoke to their hearts. Many were led to search the Scriptures with new and deeper interest, the intemperate and immoral were reformed, others abandoned their dishonest practices, and a work was done so marked that even ministers of the state church were forced to acknowledge that the hand of God was in the movement." {GC 367.1}

"I started out by faith, and not by sight; and I have seen the hand of God in every day's labor, and daily His praise has been in my heart and on my lips. His Spirit has helped my infirmities in so marked a manner that I cannot fear to commit myself to His keeping. I have the perfect assurance of His love. He has heard and answered my prayers, and I will praise Him." [RH, FEB. 5, 1884.]

"The hand of God will be recognized in the raising up of new churches. The Lord will baptize with the apostolic spirit many who will go forth to do missionary work in places where the people know not the truth." {LHU 123.6}

"My spirit shall not always strive with man." . . . The Spirit of God continued to strive with rebellious man until the time specified had nearly expired, when Noah and his family entered the ark, and the hand of God closed its door. Mercy had stepped from the golden throne, no longer to intercede for the guilty sinner." {Reflecting Christ, p.321}

THE 1843 (1850 ALSO) CHART WAS DIRECTED BY THE "HAND OF GOD" (HOLY SPIRIT)

"The Lord showed me that the **1843 chart was directed by his hand**, and that no part of it should be altered; that the figures were as he wanted them. That his hand was over and hid a mistake in some of the figures, so that none could see it, until his hand was removed.

Then I saw in relation to the "Daily," that the word "sacrifice" was supplied by man's wisdom, and does not belong to the text; and that the Lord gave the correct view of it to those who gave the judgment hour cry. When union existed, before 1844, nearly all were united on the correct view of the "Daily;" but since 1844, in the confusion, other views have been embraced, and darkness and confusion has followed. {RH, November 1, 1850 par. 11}

HOW DO WE SIN AGAINST THE "HOLY SPIRIT"?

Resisting evidence and refusing to repent (see CC 89.5 & FLB 58.8) are two ways, and another is: "... **but he who rejects the work of the Holy Spirit** is placing himself where repentance and faith cannot come to him. It is by the Spirit that God works upon the heart; when men **willfully reject the Spirit**, and declare it to be from Satan, they cut off the channel by which God can communicate with them. When the Spirit is finally rejected, there is no more that God can do for the soul. . . ." {AG 215.2}

"It is dangerous to utter a word of doubt, dangerous to question and **criticize divine light**. The habit of careless and irreverent criticism reacts upon the character, in fostering irreverence and unbelief. Many a man indulging this habit has gone on unconscious of danger, until he was ready to criticize and **reject the work of the Holy Spirit**." {DA 323.1}

"It is not God that blinds the eyes of men or hardens their hearts. He sends them light to correct their errors, and to lead them in safe paths; **it is by the rejection of this light that the eyes are blinded and the heart hardened**. Often the process is gradual, and almost imperceptible. Light comes to the soul through God's word, through His servants, or by the direct agency of His Spirit; but when one ray of light is disregarded, there is a partial benumbing of the spiritual perceptions, and the second revealing of light is less clearly discerned. So the darkness increases, until it is night in the soul. . . ." {AG 215.3}

It is clear then, that to "reject the work of the Holy Spirit" on the 1843 & 1850 charts will eventually lead to the "unpardonable sin".

A "SEVEN TIMES" WARNING TO LAODICEA

The rejection of the 2520 in 1863 was a corporate sin by the church Organization.¹⁹ It came as a consequence of their Laodicean condition. This same organization rejected the Angel of Revelation 18 in 1888.

**"The church is in the Laodicean state.
The presence of God is not in her midst."
1 Notebook Leaflets 99 (1898).**

History is being repeated!

**This chapter is dedicated to the men who have
spoken out against the 2520. May they be convicted
by the "finger" of God to be made ashamed of their sin,
BEFORE IT IS TOO LATE.**

Hebrews 3:15
To day if ye will hear his voice,
harden not your hearts, as in the provocation.

¹⁹ The leaders were symbolic of them all, and they led the "whole congregation" to sin. Read Lev. 4:13,14.



"The Majesty of Heaven is standing before the Father, pleading, 'My blood, my blood; spare the sinner a little longer for my sake.' What are you doing for him while he is pleading? Seeking your pleasure, following in the ways of folly, corruption, sin, and iniquity; and yet he is pleading his blood before the throne of his Father! Oh! can you not be entreated to come? We entreat you to come. Come now, just as you are. Come, turn and live. Come to the Burden-bearer." {RH, April 19, 1870 par. 14}

**The Saviour & King came to the Most Holy on Oct. 22, 1844
to "entreat" us to come and inherit His Kingdom.
From Manasseh ²⁰ (677 B.C.) to Christ is 2520 years.**

THE 2520 IN THE LIGHT OF THE CROSS

THE DAILY SACRIFICE & THE "SEVEN TIMES"

Exodus 29:38-43

- 29:38 Now this is that which thou shalt offer upon the altar; **two lambs** of the first year day by day continually.
- 29:39 The one lamb thou shalt offer in the morning; and the other lamb thou shalt offer at even:
- 29:40 And with the one lamb a tenth deal of flour mingled with the **fourth part of an hin** of beaten oil; and the fourth part of an hin of wine for a drink offering.
- 29:41 And the other lamb thou shalt offer at even, and shalt do thereto according to the meat offering of the morning, and according to the drink offering thereof, for a sweet savour, an offering made by fire unto the LORD.
- 29:42 This shall be a continual burnt offering **throughout your generations** at the door of the tabernacle of the congregation before the LORD: **where I will meet you, to speak there unto thee.**
- 29:43 And there I will meet with the children of Israel, and the tabernacle shall be sanctified by my glory.

Numbers 28:3-8

- 28:3 And thou shalt say unto them, This is the offering made by fire which ye shall offer unto the LORD; **two lambs** of the first year without spot day by day, for a continual burnt offering.
- 28:4 The one lamb shalt thou offer in the morning, and the other lamb shalt thou offer at even;
- 28:5 And **a tenth part of an ephah** of flour for a meat offering, mingled with the **fourth part of an hin** of beaten oil.
- 28:6 It is a continual burnt offering, which was ordained in mount Sinai for a sweet savour, a sacrifice made by fire unto the LORD.
- 28:7 And the **drink offering** thereof shall be the **fourth part of an hin** for the one lamb: in the holy place shalt thou cause the strong wine to be poured unto the LORD for a drink offering.

²⁰ Ezekiel 21:26-27 Thus saith the Lord GOD; Remove the diadem, and take off the crown: ...I will overturn, overturn, overturn, it: and it shall be no more, until he [Jesus] come whose right it is; and I will give it him. "Not until Christ Himself should **set up His kingdom** was Judah again to be permitted to have a king." {PK 451.2} "**When the four angels let go, Christ will set up His kingdom.** None receive the latter rain but those who are doing all they can. Christ would help us. All **could be overcomers by the grace of God, through the blood of Jesus.** ... {SpM 3.2} On Oct. 22, 1844, Jesus entered the Most Holy to determine/judge who would be overcomes by His grace and worthy to be subjects of His kingdom.

28:8 And the other lamb shalt thou offer at even: as the meat offering of the morning, and as the drink offering thereof, thou shalt offer it, a sacrifice made by fire, of a sweet savour unto the LORD.

The "daily sacrifice" was the original sacrifice. ²¹

"The burnt-offering [daily sacrifice] the was the earliest ritual presented by fallen man, and the most frequently mentioned in the Bible. The law emphasized no fewer than sixteen times ¹⁷ that no rite was to displace it, and all other sacrifices must be presented in addition to "the continual burnt-offering" (Num. 28:10, 15, 24, 31). Slain for centuries each morning and evening in Israel's Sanctuary as the heart of its "daily" services, this offering represented both personal and congregational consecration (Ex. 29:38-46), and by this constant repetition emphasized the need for each individual to dedicate himself to the Lord on rising, and again at retiring. Jehovah thus displayed Himself as a God of system and order (Lev. 1:7, 8, 12; 1 Cor. 14:33, 40)."

Leslie Hardinge, Ph.D., *With Jesus in His Sanctuary*, p. 369.

"As the priests morning and evening entered the holy place at the time of incense, the daily sacrifice was ready to be offered upon the altar in the court without. This was a time of intense interest to the worshipers who assembled at the tabernacle. Before entering into the presence of God through the ministration of the priest, they were to engage in earnest **searching of heart and confession of sin**. They united in silent prayer, with their faces toward the holy place. Thus their petitions ascended with the cloud of incense, **while faith laid hold** upon the merits of the promised Saviour prefigured by the atoning sacrifice. **The hours appointed for the morning and the evening sacrifice were regarded as sacred, ...**"
PP 353

**THE CROSS
& THE 2520 DAILY SACRIFICED LAMBS
with their meal offerings of Flour, Oil & Wine.**

1. The "daily sacrifice" for **3.5** years of the 70th week of Dan. 9:25-27.
2. **3.5 years x 360** prophetic days per year = **1260 days**.
3. Each one of those 1260 days had two "daily sacrifice" Lambs.
4. **1260 Lambs in the morning.**
5. **1260 Lambs in the evening.**
6. After the cross these "daily sacrificed" Lambs of the earthly Temple were meaningless.

THE MEAL MEASURES FOR THOSE 2520 LAMBS

Each Lamb had: (Num. 28:3-8)	1260 evening Lambs	1260 morning Lambs
1/10 deal of Flour	1260/10 deals of Flour = 126 ²³	1260/10 deals of Flour = 126
1/4 hin of Oil	1260/4 hins of Oil = 315	1260/4 hins of Oil = 315
1/4 hin of Wine	1260/4 hins of Wine = 315	1260/4 hins of Wine = 315
	Total Oil & Wine = 630	Total Oil & Wine = 630

²¹ "Previous to Moses's time, the burnt offering seems to be the one that had been generally used. No mention is found of any other kind, except that of Cain's, which was rejected because it lacked the element of blood, and therefore could not alone typify the coming Redeemer." {1898 UrS, LUJ 86.1}

²² 2 Chronicles 29:17 Now they began on the first day of the first month to sanctify, and *on the eighth day* of the month came they to the porch of the LORD: so they sanctified the house of the LORD in eight days; and *in the sixteenth day* of the first month they made an end.

²³ The "mene, mene, tekel, upharsin" of Daniel 5 has a monetary value of 2520 gerahs. This is equal to 126 shekels of the sanctuary (Ex. 30:13). The number 126 is put there especially for the wise virgins living after 1989, the year the prophecy of the second portion of Daniel 11:40 was fulfilled. The number of years from 1863 (the 2520 sealed up) to 1989 (Daniel 11:40 completely fulfilled) is 126 years. The 126 years is not a time prophecy, but a symbolic figure that the wise virgins will recognize.

The evening & morning "daily" Lambs for 1260 days:

2 x 1260 = **2520 Lambs**

2 x 126 deals of Flour

2 x 315 hins of Oil = **630**

2 x 315 hins of Wine = **630**

Total of Oil + Wine = 1260

The Blessing

and the Curse of "no Blood"

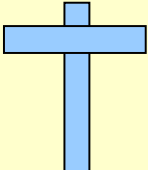
<p>3.5 years (1260 days) 2520 "daily sacrifice" Lambs 2 x 126 deals of Flour 1260 hins of Oil & Wine</p>		<p>3.5 years (1260 days) 2520 "daily sacrifice" Lambs 2 x 126 deals of Flour 1260 hins of Oil & Wine</p>
--	---	--

Ironically, the 2520 Lambs with their meal offerings prove that the "daily" is paganism, not Christ's ministry in heaven.

**Before we look at the other "daily sacrificed" Lambs:
Examine the significance of the number 49 in the Jewish economy.**

THE NUMBER 49

AT THE DEDICATION OF AARON AND HIS SONS TO THE PRIESTHOOD

Exodus 29:35-44 And thus shalt thou [Moses] do unto Aaron, and to his sons, according to all things which I have commanded thee: **seven days shalt thou consecrate them.** And thou shalt offer **every day a bullock** for a sin offering for atonement: . . . **I will sanctify also both Aaron and his sons, to minister to me in the priest's office.**

The *Blood* of the Bullock would be sprinkled
"seven times" each day for "seven days" (Lev. 4:3-7).

7 x 7 = 49

The number 49 is symbolic of consecration and cleansing. This is the number of days in the entire "feast of weeks" (49), and it is the number (49) of the "seven sabbaths of years". It is also the number of Jubilee cycles (49) from 607 B.C. to 1844 A.D. (2450 years). There were also 49 years when Judah had no consecrated Altar of Burnt-offering, and no "daily sacrifice".

The "eighth day" or "fiftieth day" signifies sanctification.

On the "eighth day":

Lev. 8:33-9:1 And ye shall not go out of the door of the tabernacle of the congregation in seven days, until the days of your consecration be at an end: for seven days shall he consecrate you. ...And it came to pass **on the eighth day**, that Moses called Aaron and his sons, and the elders of Israel;

Lev. 12:3; 14:23; 22:27; 23:36-39 all have to do with the "eighth day". For lack of space I will not insert them, but the following verse explains very clearly why the "eighth day" is so important:

2 Chron. 29:17 "Now they began on the first day of the first month to sanctify, and on the eighth day of the month came they to the porch of the LORD: so they sanctified the house of the LORD in eight days; and in the sixteenth day [eight days later] of the first month they made an end."

After 49 days of "seven sabbaths" the 50th day (Pentecost) symbolized the "eighth day".

Leviticus 23:15-16 And ye shall count unto you from the morrow after the sabbath, from the day that ye brought the sheaf of the wave offering; seven sabbaths shall be complete: Even unto the morrow after the seventh sabbath shall ye number fifty days; and **ye shall offer a new meat offering**²⁴ unto the LORD. ...two wave loaves of two tenth deals: they shall be of fine flour; they shall be baked with leaven; **they are the first fruits unto the Lord.**

After 49 "sabbaths of years", the 50th year symbolizes the "eighth day".

Lev. 25:8-12 And thou shalt number seven sabbaths of years unto thee, seven times seven years; and the space of the seven sabbaths of years shall be unto thee **forty and nine years**. **Then** shalt thou cause the trumpet of the jubilee to sound on the tenth day of the seventh month, in the day of atonement shall ye make the trumpet sound throughout all your land. And ye shall **hallow the fiftieth year**, ...For it is the jubilee; **it shall be holy unto you**: ye shall eat the increase thereof out of the field.

After 49 x 50 (2450) Jubilee cycles the 50th Great Jubilee²⁵ (1844) symbolizes the "eighth day".

The wise virgins who followed Christ by faith as he entered the Most Holy had been "set apart" and anointed for the task of ministration just as Aaron and his sons were set apart.²⁶ They had been cleansed through the first and second Angel's messages, when the parable of the "ten virgins" was fulfilled the first time.²⁷ They were the "new meal offering", the "first fruits". Their task was to take to the world the third Angel's message.

"God has given a delineation of what will come to pass in the last days of this earth's history; and the Jewish economy is full of instruction for us." {SW, October 9, 1906 par. 4}

THE SABBATHS-OF-THE-LAND LAW

Leviticus 25:3-8

Six years thou shalt sow thy field, and six years thou shalt prune thy vineyard, and gather in the fruit thereof; But in the seventh year shall be a sabbath of rest unto the land, a sabbath for the LORD: thou shalt neither sow thy field, nor prune thy vineyard. ... And thou shalt number seven sabbaths of years unto thee, seven times seven years; and the space of the seven sabbaths of years shall be unto thee forty and nine years.

1. The "seven sabbaths of years" is 49 years.
2. For 7 years of those 49 years God said the land was to have a rest.
3. **7 years x 360 days per year = 2520 days** the land was to rest.
4. Each one of those 2520 days had two "daily sacrifice " Lambs.
5. **2520 Lambs in the evening.**
6. **2520 Lambs in the morning.**
7. **Total is 5040 Lambs during those seven years = 2 x 2520.**

Each Lamb had: (Num. 28:3-8)	2520 evening Lambs	2520 morning Lambs
1/10 deal of Flour	2520/10 deals of Flour = 252 (2 x 126)	2520/10 deals of Flour = 252 (2 x 126)
1/4 hin of Oil	2520/4 hins of Oil = 630	2520/4 hins of Oil = 630
1/4 hin of Wine	2520/4 hins of Wine = 630	2520/4 hins of Wine = 630
	Total of Oil & Wine = 1260	Total of Oil & Wine = 1260

²⁴ "The new meat offering was a type of the descent of the Holy Spirit on the day of Pentecost." {1868 JW, LIFIN 162.3}
²⁵ We are still in the 50th year of Great Jubilee, as commencement of the celebration of this "year of release" has been delayed by Laodicea. There are also no longer any TIME prophecies after 1844, but rather EVENT prophecies, also much symbolism such as 126 for 2520.
²⁶ Before "the high priest and his sons could begin their ministration in the sanctuary, they were to be solemnly set apart for the task. Aaron was to be anointed with the holy oil and his sons were to be sprinkled with it at the door of the tabernacle of the congregation, where the inauguration was to take place." 1BC p. 744 (1978 version).
²⁷ "This parable has been and will be fulfilled to the very letter, for it has a special application to this time,..." written in 1890, long after 1844. {RH, August 19, 1890 par. 3}

Seven years the land was to rest.
 Seven years for the covenant to be confirmed (Dan. 9:27).

Those seven years were meant to be a "seven times" blessing:

2520 DAYS OR SEVEN YEARS OUT OF EACH 49 YEARS:		
2520 evening Lambs		2520 morning Lambs
2 x 126 deals of Flour		2 x 126 deals of Flour
1260 hins of Oil & Wine		1260 hins of Oil & Wine

(126²⁸ = 1/20th of the 2520 and is symbolic for the whole 2520)

4 x 126 = 504* but it also symbolizes 4 x 2520 which = 10,080

*504 cubits is the width of the Linen Curtain that covered the Wilderness Tabernacle. The curtain was 28 cubits wide which when multiplied by the 18" cubit = 504". There were 10 sheets to the curtain. The width of each edge on each sheet was 504" (the east and west edges). Each sheet then had a total of 1008 inches on the two edges.

10 sheets x 1008 = 10,080. Divide 10,080 by 2520 and the sum is **4 x 2520 (4 x 126).**

There are four "2520" curses in Lev. 26.

Matthew 8:11

And I say unto you, That many shall come from the **east** and **west**, and shall sit down with Abraham, and Isaac, and Jacob, in the kingdom of heaven.

Psalms 103:12

As far as the **east** is from the **west**, so far hath he removed our transgressions from us.

NO DAILY SACRIFICE FOR 49 YEARS²⁹

49 years from the destruction of Solomon's Temple in 586 B.C.
 until the Lord inspired Cyrus to issue the first decree (537 B.C.).

- | |
|--|
| <ol style="list-style-type: none"> 1. No "daily sacrifice" for 49 years. 2. 49 years x 360 prophetic days per year = 17,640³⁰ days, or "seven times". 3. Each one of those 17,640 days <i>should have had</i> <u>two</u> "daily sacrifice" Lambs. 4. 17,640 (7 x 2520) Lambs in the morning. 5. 17,640 (7 x 2520) Lambs in the evening. |
|--|

NO MORNING OR EVENING "DAILY SACRIFICE"

Each Lamb had: (Num. 28:3-8)	17,640 morning Lambs (7 x 2520)	17,640 evening Lambs (7 x 2520)
--	--	--

²⁸ The leaders were symbolic of them all, and they led the "whole congregation" to sin. (Lev. 4:13,14)

²⁹ The very first thing upon their return to the destroyed Temple grounds was to set up an altar and resume the sacrifices. (PK 560)

³⁰ 17,640 is the perimeter in North American inches around Noah's Ark of protection (using the 25.2-inch cubit; 700c x 25.2" = 17,640").

Because of their continual breaking of the "sabbaths-of-the-land" covenant God removed His arm of protection from Judah for 70 years, and also removed the Ark of the Covenant from the Temple. The literal Ark of the Covenant was never restored to them.

1/10 deal of Flour 1/4 hin of Oil 1/4 hin of Wine	17,640/10 deals of Flour = 1764 (14 x 126) 17,640/4 hins of Oil = 4410 17,640/4 hins of Wine = 4410 Total Oil & Wine = 8820 = 3.5 x 2520	17,640/10 deals of Flour = 1764 (14 x 126) 17,640/4 hins of Oil = 4410 17,640/4 hins of Wine = 4410 Total Oil & Wine = 8820 = 3.5 x 2520
---	---	---

586 to 537 B.C.		
It was a curse to have no "daily sacrifice"		
NO:		NO:
7 x 2520 morning Lambs		7 x 2520 evening Lambs
14 x 126 deals of Flour		14 x 126 deals of Flour
8820 Hins of Oil & Wine (3.5 x 2520)		8820 Hins of Oil & Wine (3.5 x 2520)

Even though it is probable that the "daily sacrifice" was not actually resumed on a new altar until the spring of 456 B.C. this does not nullify this 49 years. God sets His prophecies to begin or end according to decrees or when a king is set up or removed, as with the years 723 B.C., 677 B.C. and 1844 (King Jesus), etc. The decree in the autumn ³¹ of 457 B.C. officially ended the "70 years". At that time the curse was removed and the blessings of the sacrificial offerings were officially legal to begin again, (according to God's law). Notice that the 8820 hins of Oil & Wine when divided by the number 126 = 70 which has to be symbolic for the 70 years of captivity. Nothing is by accident in God's math.

CHAPTER 14

THE FEASTS¹⁸ ARE A COMPACTED PROPHECY OF THE GOSPEL

The Gospel of Rev. 14:6-12 - The Three Angels Messages.

"Christ was the foundation of the Jewish economy. The whole system of types and symbols was a compacted prophecy of the gospel, presentation in which were bound up the promises of redemption."
Acts of the Apostles, p.14

"In every page, whether history, or precept, or prophecy, the Old Testament

³¹ See 3BC, p. 325. The decree of 537 B.C. officially ended the 70 years captivity. 70 years previous to 537 was the year 607 B.C. In that year "Nebuchadrezzar the king of Babylon, my servant" (Jeremiah 25:9-11) was made co-regent with his father". The year 607 B.C. is the official beginning of the 70-year prophecy and also the beginning of the 49 Jubilees (2450), which along with the 2520 ended on the Day of Atonement.

18. **This is not about feast keeping.**

Scriptures are irradiated with the glory of the Son of God. So far as it was of divine institution, the entire system of Judaism was a compacted prophecy of the gospel." The Desire of Ages, p.211

"The Old Testament is the ground where the seeds of practical godliness were first sown. This was repeated in Christ's words to his disciples. We have yet to learn that the whole Jewish economy is a compacted prophecy of the gospel. It is the gospel in figures. ..." {RH, February 21, 1899 par. 5}

THE FIGURES IN THE FEASTS ARE COMPACTED

Lev. 3:2, "Speak unto the children of Israel, and say unto them, Concerning the feasts of the LORD, which ye shall proclaim to be holy convocations, even these are my feasts." The "spiritual" significance attached to certain numbers is right there in the compacted figures of the sacrifices and offerings. Examples of spiritual meanings attached to certain numbers are: "3" symbolizes the Godhead, "4" symbolizes the fourth commandment; "7" symbolizes completeness and the "seventh day Sabbath"; "8" represents resurrection; "10" the Ten Commandments and the ten divisions of the world; "12" the twelve disciples; "18" the power of God as in Rev. 18; "144" the one-hundred-forty-four thousand; "1260" represents days or years and is also symbolized by 3.5.

The figures in the "feasts of the Lord" also symbolize those same figures with additions such as "42" symbolizes 42 months and 1260 years, so "84" represents 84 months and 2520 years. 126 is symbolic for 2520 (Dan.5), and 12.6 is symbolic for 1260. 24.5 = 2450. The number 49 also represents 7 x 7 and sanctification, as will be seen in the following work.

INTRODUCTION

God had a reason for being so specific about His three required feast days. We are told to study the "Jewish economy", "the building of the tabernacle and the temple"

"As a people and as individuals we need to have a deeper sense of our duty to God and our responsibility to the world. There should be more earnest study of the Scriptures. I have been deeply impressed with the importance of studying the book of Daniel in connection with the smaller prophets, especially Malachi. And we need to give careful attention also to the lessons taught in the building of the tabernacle and the temple, and in the temple service. "Through the prophets God has given a delineation of what will come to pass in the last days of this earth's history, and the Jewish economy is full of instruction for us."¹⁹ {RH, November 10, 1896 par. 11}

The Bible details the measurements Moses and Solomon were to build the Temple by. A temple cannot be built without measuring all the materials carefully, and the "temple services" are rituals carried out with the sacrifices and the meal offerings which also have to be measured.

The introduction to Leviticus in Volume One of the Seventh-day Adventist Bible Commentary, (1978 version), was the most helpful. Who would ever have dreamed that the tedious measures given for

19. This article is about tithing. She connects the building of the Tabernacle by Moses and the Temple Solomon built with their sanctuary rituals to tithing. There is much more depth of meaning to her words than can be related here.

all the sacrifices would become such an interesting subject to study! Stephen N. Haskell wrote:

"Every type used in the entire sacrificial system was designed by God to bear resemblance to some spiritual truth. The value of these types consisted in the fact that they were chosen by God Himself to shadow forth the different phases of the **complete plan of redemption, made possible by the death of Christ**. The likeness between type and antitype is never accidental, but is simply a fulfillment of the great plan of God." {1914 SNH, The Cross and its Shadow, p. 6.2}

"The entire system of Judaism was the gospel. True, it was veiled in types and symbols, but the light from Calvary illuminates the entire Jewish economy; and the one who will study it **in the light of the cross**, will gain such an intimate acquaintance with Him who is the Antitype of every service, that by beholding they will become changed into His image, from glory to glory." {1914 SNH, CIS 243.3}

(There is much more to understand about the sums in these feasts than is presented here.)

SOME OF THE FIGURES IN THE FEASTS

Here are a few samples for the feasts. More info on the numbers of animals used for each service can be found in 1BC 698

1. **2300 hins of Oil and 2300 hins of Wine were offered with the Bulls during a 50-year Jubilee cycle.**
2. **Each year there were 84 Lambs during *Unleavened Bread, Pentecost, Trumpets & Day of Atonement*.**
 - a) 84 Lambs x a 50-year Jubilee cycle = 4200 Lambs
 - b) The Flour adds up to 4200/10, which is 420 deals of Flour.
 - c) The Oil & Wine add up to 8400/4, which is 2100 hins of Oil & Wine.
 - d) The 420 deals of Flour plus the 2100 hins of Oil & Wine = 2520.
3. **In the 50 years of a Jubilee cycle there are 2450²⁰ Lambs in the *Feast of Unleavened Bread*.**
4. **In the 50 years of a Jubilee cycle there are 4900 Lambs in the *Feast of Tabernacles*.**
 - a) Those 4900 Lambs have 490 deals of Flour & 2450 hins of Oil and Wine.
5. **There were 4 one-day feasts: (*Pentecost, Trumpets, Day of Atonement, and the Eighth day of Tabernacles*).**
 - a) There were 42 Lambs. The 42 Lambs x 50 years = 2100 Lambs = 1260 deals of Flour, Wine & Oil.
6. **Those same 4 feasts had 9 Rams:**
 - a) Every 7 years there were 12.6 deals of Flour, and 42 hins of Oil & Wine (1260 yrs. = 42 months).
 - b) 12.6 x 100 = 1260; 42 x 30 = 1260. (This is a formula that can be used to figure the compacted prophecies!)
7. **Each year there were 147 Lambs offered during *Feast of Unleavened Bread and Tabernacles*.**
 - a) 147 Lambs x 50 years (Jubilee) = 7350 Lambs or 3 x 2450.
 - b) The offerings with the 7350 Lambs had 735 deals of Flour.
 - c) There were 3675 hins of Oil & Wine offered with those Lambs.
 - d) 3675 + 735 = 4410. 4410 divided by 1260 = 3.5.

²⁰ The number 2450 is 49 x 50 Jubilee years. There were 2450 years from 607 B.C. to 1844.

8. **Each year the Bulls in the Feast of Unleavened Bread and Tabernacles add up to 84.**
- 84 Bulls per year x 3/10 Flour = 252²¹.
 - 84 Bulls x 50-year Jubilee cycle = 4200 Bulls.
 - 4200 Bulls with 3/10 deal of Flour each = 12600/10 = 1260.
9. **Every 7 years Feast of Unleavened Bread = 490 animals (70 animals per year.)**
10. **Every 7 years of Pentecost = 70 animals.**
11. **Every 49 years of Pentecost = 490 animals.**
12. **Every 7 years of Feast of Tabernacles has 490 Bullocks.**
13. **Feast of Trumpets** (Philadelphia – Millerites) and **Day of Atonement** (Laodicea – modern Israel) have **9 & 11** in their number of animals. The Third Angels message: Rev. 14:9-11. Read 9T p.11 (coincidences?)²²
14. **There are a total of 18 days of Feasts each year.**
- Each day has two “daily” sacrifice Lambs = 36 Lambs.
 - 36 Lambs x 7 years = 252 Lambs (2 x 126, see footnote #9).
15. **There are two feasts, each with “seven days” duration:**
- Week of Unleavened Bread* (Numbers 28:17-25) has 70 animals.
- Week of Tabernacles* (Numbers 29:12-34) has 182 animals.
- 182 + 70 = 252. **252 animals = 2 x 126** (interesting that this is the same number of animals in Num.7.)
16. **Up to and including the Day of Atonement** (close of probation time), **all the feast animals** add up to 120.
- 120 animals x 50 years = 6000.
17. **Each year has 4 one-day feasts: (Pentecost, Trumpets, Day of Atonement, and the Eighth day of Tabernacles).**
- There are a total of 8 Bulls each year in those four feasts.
 - The Flour measure is 24/10 or 2.4. 2.4 x 50 Jubilee cycles = 120.
 - Those 50 Jubilee cycles x 120 (years) = 6000 (years). We are on borrowed time!
 - When Jesus comes the Jubilee will resume. (EW 35). Sadly, Laodicea has delayed the Jubilee this far.

ATTENDANCE REQUIRED THREE TIMES A YEAR

Unleavened Bread - Pentecost – Tabernacles

God does not include the Passover at even-time in with his "three times" a year declaration. The Paschal Lamb was eaten in individual homes, while the sacrifices of all the feasts were done in the Temple on behalf of the "whole congregation".

(Not sure if it should be put with the not-required feasts but there is a 3 + 1 combination if I do.

If Passover is included in the three required feasts it would also make a 3 + 1 combination.)

Read: Lev. 23:14-15, Deut. 16:16, 2 Chron. 8:13

Leviticus 23:1-4

23:1 And the LORD spake unto Moses, saying,

23:2 Speak unto the children of Israel, and say unto them, Concerning the feasts of the LORD, which ye shall proclaim to be holy convocations, even these are my feasts.

23:3 Six days shall work be done: but the seventh day is the sabbath of rest, an holy convocation; ye shall do no work therein: it is the sabbath of the LORD in all your dwellings.

23:4 These are the feasts of the LORD, even holy convocations, which ye shall proclaim in their seasons.

The first feast:

Leviticus 23:5-6

23:5 In the fourteenth day of the first month at even is the LORD's passover.

23:6 And on the fifteenth day of the same month is the feast of unleavened bread unto the LORD: seven days ye must eat unleavened bread.

The second feast: Pentecost. This feast celebrates the previous six weeks of harvest.

Deuteronomy 16:10

And thou shalt keep the feast of weeks unto the LORD thy God with a tribute of a freewill offering of thine hand, which thou shalt give unto the LORD thy God, according as the LORD thy God hath blessed thee:

²¹ The total number of animals given at the Dedication of the Altar was 252! Read Num. 7:87-88.

²² See Jer. 9:11, Eze. 9:11, Dan. 9:11, Amos 9:11, & Rev. 9:11. Since 666 is symbolic, then 9/11 can be symbolic also.

This "[weeks](#)" is a plural of H7620, the exact same as the plural of Dan. 9:25: "seven weeks".

Lev. 23:15

And ye shall count unto you from the morrow after the sabbath, from the day that ye brought the sheaf of the wave offering; [seven sabbaths shall be complete](#).

(Later we will compare this with Lev. 25:8 and the "sabbaths of years".)

The third feast:

Leviticus 23:34

Speak unto the children of Israel, saying, The fifteenth day of this seventh month shall be [the feast of tabernacles](#) for [seven days](#) unto the LORD.

During these feasts, besides the special sacrifices offered, the "daily sacrifice" continued without interruption.

FOUR ONE-DAY FEASTS NOT REQUIRED

(but attendance was highly recommended).

1. Leviticus 23:5 - Passoverⁱ on the 14th Day.
In the fourteenth day of the first month at even is the LORD's passover.
2. Numbers 29:1 - Feast of Trumpets
And in the seventh month, on the first day of the month, ye shall have an holy convocation; ye shall do no servile work: it is a day of blowing the trumpets unto you.
3. Num. 29:7 - Day of Atonement
And ye shall have on the tenth day of this seventh month an holy convocation; and ye shall afflict your souls: ye shall not do any work therein:
4. Numbers 29:35 - The day after Tabernacles: The 8th day.
On the eighth day ye shall have a solemn assembly: ye shall do no servile work therein:

THE FIRST TWO REQUIRED FEASTS

(The majority of the sums have the multiples of 7 and 49)

These two feasts are symbolic of the first and second Angel's messages. The Feast of Unleavened Bread is for seven days.

Following that week is six weeks of harvesting. The 50th day (Pentecost), prefigured the "Midnight Cry" of 1844.

<p>TWO REQUIRED FEASTS</p> <p>1. Week of Unleavened Bread. (Six weeks of harvesting.)</p> <p>2. Pentecost celebration.</p> <p>(3. Tabernacles is the 3rd required Feast) (...in the autumn of the year.)</p> <p>The first two feasts = 3.5 (1260)</p>	<p>TWO REQUIRED MESSAGES</p> <p>1. First Angel, empowered Aug. 11, 1840 (2nd Angel is harvesting)</p> <p>2. Aug. 12-17, 1844: Midnight Cry.</p> <p>(3. 3rd Angel arrives on Oct. 22, 1844.) (...in the autumn of the year.)</p> <p>The first two Angels: 1840-1844</p>
--	---

THE FEASTS IN THEIR CHRONOLOGICAL ORDER:

(The Paschal Lamb feast is not included here. This Lamb was eaten in the homes of individuals, while the priests offered these last six feasts on behalf of the "whole congregation" at the Temple.)

Daniel 9:27 And he shall confirm the covenant with many **for one week**: and in the midst of the week [3.5] he shall cause the sacrifice and the oblation to cease ...

Feast of Unleavened Bread

	Each Bullock has:			Each Ram has:			Each Lamb has:		
	3/10 deal Flour	2/4 hin Oil	2/4 hin Wine	2/10 deal Flour	1/3 hin Oil	1/3 hin Wine	1/10 deal Flour	1/4 hin Oil	1/4 hin Wine
1 year 70²³	14 Bulls			7 Rams			49 Lambs		
	42/10	28/4	28/4	14/10	7/3	7/3	49/10	49/4	49/4
7 years	294/10	196/4	196/4	98/10	343/3	343/3	343/10	343/4	343/4
Pentecost									
1 year 20	3 Bulls			3 Rams			14 Lambs		
	9/10	6/4	6/4	6/10	3/3	3/3	14/10	14/4 = 3.5	14/4 = 3.5
FEAST OF UNLEAVENED BREAD: Each year there were 70 animal offerings. 70 animals x 7 years = 490 = probationary time for Israel.					PENTECOST Each year there were 20 animal offerings. 20 animals x 7 years = 140²⁴				

There are dozens of Biblical prophetic years in these charts and on the following page. There does not appear to be a specific pattern yet, just lots of parts. Hopefully someone else can discover the patterns and what they represent. God is a God of order, not confusion. The majority of the sums are multiples of 7 and 49, but there are also fractions of 2520, 2450, 1260, 126, etc. The number 441 is usually found with the Lambs. 441 is 3.5 x 126; 441 is also 9 x 49. The fraction 3.5 is also present throughout the figures. I am only going to highlight the 3.5 figures and a couple other things on the following pages.

After Unleavened Bread and Pentecost come the following feasts:
(these are not the daily Lambs.)

An interesting sum with the Lambs of these *four feast days*:

<p>One year of Lambs</p> <p>126 Lambs</p> <p>126/10 deals of Flour</p> <p>126/4 hins of Oil</p> <p>126/4 hins of Wine</p>
--

Each Bullock has:			Each Ram has:			Each Lamb has:		
3/10 deal Flour	2/4 hin Oil	2/4 hin Wine	2/10 deal Flour	1/3 hin Oil	1/3 hin Wine	1/10 deal Flour	1/4 hin Oil	1/4 hin Wine

Feast of Trumpets

1 year 19²⁵	3 Bulls			2 Rams			14 Lambs		
	9/10	6/4	6/4	4/10	2/3	2/3	14/10	14/4 = 3.5	14/4 = 3.5
7 years 133	21 Bulls			14 Rams			98 Lambs		
	63/10	42/4	42/4	28/10	14/3	14/3	98/10	98/4	98/4
Day of Atonement									
1 year 11	1 Bullock			3 Rams			7 Lambs		
	3/10	2/4	2/4	6/10	3/3	3/3	7/10	7/4	7/4

23. These numbers in this column are the number of animals for the year(s).

24. There were 140 years from 677 B.C. to the first decree of Cyrus in 537 B.C.

25. These numbers in this column are the number of animals for the year(s).

7 years 77	7 Bullocks			21 Rams			49 Lambs		
	21/10	14/4 = 3.5	14/4 = 3.5	42/10	21/3	21/3	49/10	49/4	49/4
There are 120 (1 year) animals up to and including Day of Atonement: 120 years = probation for Noah's generation. Feast of Tabernacles is the third required feast.									
1 year 182	70 Bullocks			14 Rams			98 Lambs		
	210/10	140/4	140/4	28/10	14/3	14/3	98/10	98/4	98/4
7 years 1274	490 Bullocks			98 Rams			343 Lambs		
	1470/10	980/4	980/4	196/10	98/3	98/3	686/10	686/4	686/4

The 8th day of Tabernacles

1 year 9	1 Bullock			1 Ram			7 Lambs		
	3/10	2/4	2/4	2/10	1/3	1/3	7/10	7/4	7/4
7 years 63	7 Bullocks			7 Rams			49 Lambs		
	21/10	14/4 = 3.5	14/4 = 3.5	14/10	7/3	7/3	343/10	343/4	343/4

THE BULLOCKS & THE GOATS OF THE SIN-OFFERING ON THE DAY OF ATONEMENT FOR 3.5 YEARS.

During the 3.5 years of the ministry of Christ, the Blood of a Bullock was sprinkled "seven times" on the Mercy Seat, and the Blood of a Goat was sprinkled "seven times" on the Mercy Seat. This was a total of 14 times a year for 3.5 years. **14 x 3.5 = 49 times.**

THE COUNTDOWN IN TABERNACLES

“We all entered the cloud together, and were seven days ascending to the sea of glass...” EW 16

(note the decreasing number of bullocks offered)

Day	Bullocks	Rams	Lambs	Goat (sin offering)
1.	<u>13</u>		2 (2x usual)	14 (2x usual) 1
2.	<u>12</u>		“	“ “
3.	<u>11</u>		“	“ “
4.	<u>10</u>		“	“ “
5.	<u>9</u>		“	“ “
6.	<u>8</u>		“	“ “
7.	<u>7</u>		“	“ “
8.	1		1 (usual #)	7 (usual #) “ (the “Great Day”)

John 7:37-38, In the last day, that great day of the feast, Jesus stood and cried, saying, If any man thirst, let him come unto me, and drink. He that believeth on me, as the scripture hath said, out of his belly shall flow rivers of living water.

In DA 453-454 we read that Jesus offered His people "living water" that, had they accepted His offer, would have taken them up to the "sea of glass".

Sadly, they did not accept His offer.

Now it is our turn.

There were a total of 630 Bulls offered with 2520/4 hins of Oil & Wine every *seven years*!



The blood of 2520 Lambs was a blessing while Christ walked among men - *until the Cross*, and afterward, there was a curse of no blood, and no 2520 Lambs upon the nation/church of Judah.

There were 2 x 2520/10th deals of Flour offered every *seven years*

There were 1260 hins of Oil & 1260 hins of Wine every *seven years* (1260 + 1260 = 2520).